

# 수능특강

영어영역 | 영어독해연습

# 이 책의 특징, 활용법 및 구성

## 이 책의 특징

본 교재는 2026학년도 대학수학능력시험을 준비하는 데 도움을 주고자 제작되었으며, 2015 개정 영어과 교육과정을 반영하였다. 특히 학생들의 읽기 능력 신장을 목적으로 하여 교과 내용을 토대로 더욱 다양하고 참신한 주제·소재·분야의 글과 정보를 제시하였고, 교육과정상의 어휘 범주와 지문의 내용을 고려하여 제작되었다. 학교에서 영어 I, 영어 II 교과서를 바탕으로 영어 독해의 기본 개념과 어휘를 철저히 익힌 후, 본 교재를 활용한 독해 훈련으로 실제 응용력을 키우면, 교육과정 성취 목표 도달과 함께 대학수학능력시험 대비에 크게 도움이 될 것으로 기대된다.

## 이 책의 효과적인 활용법

본 교재를 효과적으로 활용하여 독해 능력을 향상하고 수능 영어 읽기 영역에 완벽하게 대비하기 위해서 학업 성취 기간을 정하여 '이 책의 차례'에 제시된 학습 내용을 차근차근 공부하되 다음과 같은 사항에 유의하도록 하자.

### 능동적이고 적극적인 학습 자세

수동적이고 소극적으로 강의를 듣기만 할 것이 아니라 강의하는 선생님과 토론하고 대화한다는 자세로 임하는 것이 중요하다. 이와 같은 자세는 핵심적인 부분의 이해와 학습 내용의 기억에 도움이 된다. 또한 중요한 사항을 교재 여백에 메모하여 강의를 듣는 것이 좋다. 이것은 학습 내용의 심층적인 이해와 효율적인 복습을 위해 꼭 필요하다.

### 예·복습과 정리를 통한 내재화

영어 학습은 유의미한 내재화가 중요하다. 따라서 학습 내용을 미리 예습하고 여러 번 복습하면서 주요 어휘와 문장 구조를 파악하고 글의 내용을 자신이 이미 알고 있는 지식과 연관하여 문제 풀이에 접목할 수 있어야 한다.

## 이 책의 구성

### 틀리기 쉬운 유형편 01 ~ 12강

수능 읽기 영역에서 틀리기 쉬운 11가지 유형을 집중 학습할 수 있도록 강과 문항을 유형별로 구성하였다. 다양한 소재와 주제의 지문을 통해 어려운 유형을 집중적으로 학습하여 해당 유형에 대한 문제 해결력을 높일 수 있도록 하였다.

### Sentence Structure

각 지문 중에서 어법상 중요하거나 글의 내용 파악에 핵심이 되는 문장을 발췌하여 철저한 분석과 구문 설명을 제시함으로써 지문에 대한 정확한 이해를 돕고자 하였다.

### Word Search

지문에서 알아두어야 할 어휘의 예문을 제시하고 문맥상 적절한 영어 단어를 지문에서 찾아 빈칸에 직접 써 보게 함으로써 어휘의 뜻을 정확히 파악할 수 있도록 하였다.

### Mini Test 1 ~ 3회

Mini Test 3회분으로 구성되어 있으며, 2026학년도 대학수능능력시험 문제로 출제될 가능성이 있는 모든 독해 유형을 포함하였다. 1강에서 12강까지 모두 학습한 후 Mini Test를 통해 자신의 실력을 최종적으로 간단히 점검할 수 있다.

### 정답과 해설

[정답] - [소재] - [해석] - [문제 해설] - [구조 해설] - [어휘 및 어구] - [Tips]의 순서로 구성되어 있다. 먼저 각 문항의 소재를 제시하여 글의 전반적인 내용에 대한 이해를 유도하고자 하였고, 이어서 정확한 해석과 함께, 정답에 이르는 과정을 상세하게 해설하여 자기 주도 학습이 가능하도록 하였다. 그리고 구조 해설과 어휘 및 어구를 통해 정확하고 핵심적인 구문 이해에 도움이 되도록 구성하였으며, Tips에서는 지문의 내용에 대한 배경 지식이나 부가적 정보를 제공하였다.

Week 1 **01** 강

**Exercise 1** 빈칸 추론

다음 빈칸에 들어갈 말로 가장 적절한 것은?

**Sentence Structure**

- We've taken steps [to make this object (more and more) different from any specific lemon (you've ever encountered)] [ ]는 steps를 수식하는 to부정사구이다. 그 안의 두 개의 { }는 any specific lemon을 수식하는 관계절이다.

**Word Search** 주어진 문장에 들어갈 적절한 영어 단어를 고르시오

1. This new product falls under the electronics c
2. I e \_\_\_\_\_ an old friend at the town coffe
3. The submission deadline will be extended only i

Week 7 **Mini Test 1**

**01** 다음 글의 목적으로 가장 적절한 것은?

Dear Dr. Stevens,

For the past four years, volunteering at the Lanefor

Week 1 **01** 강 문항 6~17쪽

1 ㉞	2 ㉟	3 ㊱	4 ㊲	5 ㊳	6 ㊴
7 ㊵	8 ㊶	9 ㊷	10 ㊸	11 ㊹	12 ㊺

**Exercise 1** 정답 ㉞

**소요** 전황상에 의존하지 않는 범주 판단

**해설** 전황상에 의존하지 않을 때 범주 판단은 어떻게 이루어지는가? 이 질문에 대한 접근 방법으로 한 가지 예에 대해 충실히 생각해 보자. 레몬을 생각해 보자. 레몬에 빨간색과 흰색 줄무늬를 칠해 보자. 그것은 여전히 레몬인가? 대부분의 사람은 그렇다고 말한다. 이제 레몬에 달콤한 맛이 나도록 설탕물을 주입하라. 그런 후 켈케이크처럼 편평해지도록 트릭으로 레몬 위를 달리 보라. 이 시점에서 우리는 무엇을 알았는가? 줄무늬가 있으며, 인위

abuse 학대하다, 후사B  
object 물체  
distant 멀리 있는  
encounter 접하다. (주)  
exceptional 예외적인  
apparently 보이거나,  
virtually 거의, 사실상  
resemblance 닮음, 비

**Word Search**

**정답** | 1. category  
2. 이 새로운 제품은 전지  
3. 나는 지난주에 시내 카  
3. 재출 마감일은 예외적

# 이 책의 차례

## 틀리기 쉬운 유형편

학업 성취 9주 계획	강	제목	페이지	
Week <b>1</b>	01	빈칸 추론 함축 의미 추론	6	
	02		18	
Week <b>2</b>	03		30	
	04		42	
Week <b>3</b>	05		어법 주제 추론 제목 추론 무관한 문장 글의 순서	54
	06			66
Week <b>4</b>	07	78		
	08	90		
Week <b>5</b>	09	어휘 문장 삽입 요약문 완성 1지문 2문항		102
	10			114
Week <b>6</b>	11		126	
	12		138	

# Contents

## Mini Test

학업 성취 9주 계획	제목	페이지
Week <b>7</b>	<b>Mini Test 1</b> 수능 독해 실전모의고사	150
Week <b>8</b>	<b>Mini Test 2</b> 수능 독해 실전모의고사	176
Week <b>9</b>	<b>Mini Test 3</b> 수능 독해 실전모의고사	202

학생

### 인공지능 DANCHO 푸리봇 문제|검색

EBSi 사이트와 EBSi 교강강의 APP 하단의 AI 학습도우미 푸리봇을 통해 문항코드를 검색하면 푸리봇이 해당 문제의 해설과 해설 강의를 찾아 줍니다. 사진 촬영으로도 검색할 수 있습니다.

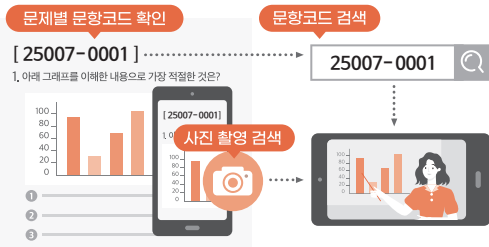

선생님

### EBS 교사지원센터 교재 관련 자료|제공

교재의 문항 한글(HWP) 파일과 교재이미지, 강의자료를 무료로 제공합니다.



- 교사지원센터(teacher.ebsi.co.kr)에서 '교사인증' 이후 이용하실 수 있습니다.
- 교사지원센터에서 제공하는 자료는 교재별로 다를 수 있습니다.



## Exercise 2

## 빈칸 추론

다음 빈칸에 들어갈 말로 가장 적절한 것은?

25007-0002

There's a reason so many of the studies that found that \_\_\_\_\_ were conducted with children. Children are busy figuring out their likes and dislikes. When I ask my eight-year-old if he likes a subject at school, he needs to think about it; he doesn't intuitively know the answer the way you might. Children are relatively new to a world that's largely controlled by adults, so many of the activities that occupy their days need explanation. They might ask themselves, "Am I drawing because I like to draw or because my teacher made me draw?" or "Does this food taste good to me or am I eating it because otherwise I won't get dessert?" Incentives give them the clues to start piecing together their likes and dislikes. And if you're a child, and an adult is willing to pay you to do something, that's a clue that you wouldn't otherwise enjoy doing it.

- ① it pays to trust our intuition
- ② we act in our own self-interests
- ③ incentives undermine motivation
- ④ old preferences can last a lifetime
- ⑤ rewards work better than punishment

## Sentence Structure

- Children are relatively new to a world [that's largely controlled by adults], so [many of the activities {that occupy their days}] need explanation.  
 첫 번째 [ ]는 a world를 수식하는 관계절이다. 두 번째 [ ]는 so가 이끄는 절의 주어이고, 그 안의 { }는 the activities를 수식하는 관계절이다.

Word Search 주어진 문장에 들어갈 적절한 영어 단어를 본문에서 찾아 쓰시오. (필요시 형태를 바꿀 것)

1. He has a **d** \_\_\_\_\_ for people who are rude and impolite.
2. Problems at work continued to **o** \_\_\_\_\_ his mind for some time.
3. The cash bonus turned out to be a powerful **i** \_\_\_\_\_ for employees.

**Exercise 3** 빈칸 추론

다음 빈칸에 들어갈 말로 가장 적절한 것은?

25007-0003

Because both parties typically suffer costs when a competition escalates to violence, contests between members of the same species are typically a blend of truth and exaggeration by each party intended to convince the other party to back down. Exaggeration would disappear if there were no cost to testing one's abilities against those of one's opponent. If we're competing over the last slice of cake and I think I might be stronger than you, I'll just punch you and find out. But there is a notable cost to this test, as you are likely to punch me back — a bummer under the best of circumstances, but particularly so if you're stronger than I am. It is this \_\_\_\_\_ that allows deceptive individuals to exaggerate their strengths and play down their weaknesses without necessarily getting caught. This type of exaggeration can be seen throughout the animal kingdom, such as when moose or hyenas raise the hackles on their back to appear larger, or when crabs grow unnecessarily large claw shells that they do not fill with muscle.

\* bummer: 불쾌한 경험 \*\* hackles: 목덜미 털

- ① heavy price of inaction
- ② constant pursuit of harmony
- ③ guaranteed cost of competition
- ④ innate preference for physical conflict
- ⑤ excessive underestimation of the opponent

**Sentence Structure**

- This type of exaggeration can be seen throughout the animal kingdom, such as [when moose or hyenas raise the hackles on their back to appear larger], or [when crabs grow unnecessarily large claw shells {that they do not fill with muscle}].

두 개의 [ ]는 시간의 부사절로 or로 연결되어 such as에 이어진다. 두 번째 [ ] 안의 { }는 unnecessarily large claw shells 를 수식하는 관계절이다.

**Word Search** 주어진 문장에 들어갈 적절한 영어 단어를 본문에서 찾아 쓰시오. (필요시 형태를 바꿀 것)

1. Tensions continued to e \_\_\_\_\_ between the two rival nations.
2. Her claim that the fish she caught was as big as a whale was a clear e \_\_\_\_\_.
3. The advertisement's d \_\_\_\_\_ claims misled many consumers.

## Exercise 4 빈칸 추론

다음 빈칸에 들어갈 말로 가장 적절한 것은?

25007-0004

Other people's reactions can influence whether any one individual decides to help. No one wants to foolishly rush to help in a case that may not be an emergency after all. In fact, people sometimes fail to act because they fear appearing foolish in front of others. So we usually keep calm and check to see what others present are doing. Of course, if everyone else is also keeping calm while they check the reactions of others, everyone will conclude that help is not needed or that norms make helping inappropriate. In one series of studies, experimenters arranged for smoke to pour into a laboratory room in which students were sitting completing questionnaires. When the students were alone, their concern at the unusual situation soon led them to seek help. But when two confederates in the room showed no reaction to the smoke, participants also did nothing. When people notice that bystanders and passersby are unresponsive, that observation reduces the likelihood that they will help. Thus, one way that the presence of bystanders can influence helping is by \_\_\_\_\_.

\* confederate: (실험) 공모자

- ① suggesting that helping is contrary to norms
- ② keeping others from taking unnecessary risks
- ③ following the norms that would secure safety
- ④ encouraging people to take notice of the rewards
- ⑤ emphasizing that norms should be applied to everyone

### Sentence Structure

- Of course, [if everyone else is also keeping calm {while they check the reactions of others}], everyone will conclude [{that help is not needed} or {that norms make helping inappropriate}].

첫 번째 [ ]는 조건의 부사절이고, 그 안의 { }는 시간의 부사절이다. 두 번째 [ ]는 conclude의 목적어인데, 그 안에 명사절인 두 개의 { }가 or로 연결되어 있다.

**Word Search** 주어진 문장에 들어갈 적절한 영어 단어를 본문에서 찾아 쓰시오. (필요시 형태를 바꿀 것)

1. Each culture develops its own social **n** \_\_\_\_\_.
2. The **p** \_\_\_\_\_ quickly called for help after he witnessed the car accident on the busy street.
3. The customer service representative remained **u** \_\_\_\_\_ to my inquiries, leaving me dissatisfied.

**Exercise 5** 빈칸 추론

다음 빈칸에 들어갈 말로 가장 적절한 것은?

25007-0005

There is a profound reason to start natural philosophy with the ancient Greeks rather than the older cultures (Egyptian, Babylonian, Indian, and Chinese), despite their many accomplishments. Although these older cultures had technical knowledge, keen observational skills, and vast resources of material and information, they failed to create natural philosophy because they \_\_\_\_\_. The religions of the old empires were predicated on the belief that the material world was controlled and inhabited by supernatural beings and forces, and that the reason for the behavior of these supernatural forces was largely unknowable. Although there were many technical developments in the societies of the four river cultures, the intellectual heritage was dominated by the priests, and their interest in the material world was an extension of their concepts of theology. Many ancient civilizations, such as the Egyptian, Babylonian, and Aztec empires, spent a large proportion of social capital (covering such things as the time, wealth, skill, and public space of the society) on religious activity.

\* be predicated on: ~에 근거하다 \*\* theology: 신학

- ① could not integrate technical knowledge into their religious frameworks
- ② regarded philosophical endeavors as secondary to practical pursuits
- ③ had no system through which to pass on their intellectual heritage
- ④ did not separate the natural world from the supernatural world
- ⑤ downplayed the importance of abstraction and spirituality

**Sentence Structure**

- The religions of the old empires were predicated on the belief [{that the material world was controlled and inhabited by supernatural beings and forces}], and {that <the reason for the behavior of these supernatural forces> **was** largely unknowable}].

[ ]는 the belief와 동격 관계를 이루고, 그 안에 두 개의 { }가 and로 대등하게 연결되어 있다. 두 번째 { } 안에서 < >는 절의 주어, 주어의 핵심어가 the reason이므로 단수형 동사 was가 사용되었다.

**Word Search** 주어진 문장에 들어갈 적절한 영어 단어를 본문에서 찾아 쓰시오. (필요시 형태를 바꿀 것)

1. René Descartes is regarded as the founder of modern p\_\_\_\_\_.
2. The tribe's shared cultural h\_\_\_\_\_ fostered a deep sense of community and belonging.
3. The ancient temple held deep r\_\_\_\_\_ significance for the community.

## Exercise 6 함축 의미 추론

밑줄 친 the ruler sitting at his desk가 다음 글에서 의미하는 바로 가장 적절한 것은?

25007-0006

The processes of state formation and the centralization of government in early modern Europe involved the use of increasing amounts of information. Historians have noted the rise of what the Canadian sociologist Dorothy Smith called ‘textually mediated forms of ruling’ such as writing letters, writing and annotating reports, issuing forms and questionnaires and so on, associated with what is variously known as the information state, archive state or paper state — now in the process of transforming itself into the digital state. This process may be described as the rise of ‘bureaucracy’ in the original sense of the term, the rule of the bureau, or office, and its officials. These officials both issued and followed written orders and recorded these orders in their files, together with the reports on the political situation at home and abroad that assisted decision-making. The ruler on horseback was gradually transformed into the ruler sitting at his desk, as in the famous cases of Philip II of Spain in the sixteenth century and Louis XIV of France in the seventeenth.

\* mediate: (정보 등을) 매개하다 \*\* annotate: 주석을 달다 \*\*\* bureaucracy: 관료제

- ① a governor who engages in extensive discussions before reaching a decision
- ② a dictator who controls the flow of information to suppress the opposition
- ③ a king without a centralized authority and a formal bureaucratic structure
- ④ a head of state who favors peaceful negotiations over armed conflict
- ⑤ a leader who relies on written communication to govern a state

### Sentence Structure

- Historians have noted [the rise of {what the Canadian sociologist Dorothy Smith called <‘textually mediated forms of ruling’ such as writing letters, writing and annotating reports, issuing forms and questionnaires and so on>}, {associated with what is variously known as the information state, archive state or paper state — now in the process of transforming itself into the digital state}]].

[ ]는 noted의 목적어이다. 첫 번째 { }는 전치사 of의 목적어로 사용된 명사절이고, 그 안의 < >는 called의 목적격 보어로 사용된 명사구이다. 두 번째 { }는 첫 번째 { }를 부가적으로 설명하는 분사구문이다.

**Word Search** 주어진 문장에 들어갈 적절한 영어 단어를 본문에서 찾아 쓰시오. (필요시 형태를 바꿀 것)

1. Excessive **c** \_\_\_\_\_ often hinders individual creativity and innovation.
2. New members will be **i** \_\_\_\_\_ with a temporary identity card.
3. The new software is designed to **a** \_\_\_\_\_ users in managing their finances.

**Exercise 7** 빈칸 추론

다음 빈칸에 들어갈 말로 가장 적절한 것은?

25007-0007

The primary goal of replication is to determine the extent to which an observed relationship generalizes across different tests of the research hypothesis. However, just because a finding does not generalize does not mean it is not interesting or important. Indeed, science proceeds by \_\_\_\_\_. Few relationships hold in all settings and for all people. Scientific theories are modified over time as more information about their limitations is discovered. As an example, one of the interesting questions in research investigating the effects of exposure to violent material on aggression concerns the fact that although it is well known that the viewing of violence tends to increase aggression on average, this does not happen for all people. So it is extremely important to conduct participant replications to determine which people will, and which will not, be influenced by exposure to violent material.

\* replication: 반복 실험

- ① developing specialized knowledge designed for specific groups
- ② emphasizing the discovery of a hypothesis that can be generalized
- ③ generating numerous hypotheses across different fields of research
- ④ discovering limiting conditions for previously demonstrated relationships
- ⑤ helping the human population adapt to limits imposed by the environment

**Sentence Structure**

- As an example, one of the interesting questions in research investigating the effects of exposure to violent material on aggression concerns the fact [that {although it is well known <that the viewing of violence tends to increase aggression on average>}], this does not happen for all people].

[ ]는 the fact의 구체적인 내용을 설명하는 동격절이고, 그 안의 { }는 양보의 의미를 나타내는 부사절이다. { } 안의 it은 형식상의 주어이고, < >가 내용상의 주어이다.

**Word Search** 주어진 문장에 들어갈 적절한 영어 단어를 본문에서 찾아 쓰시오. (필요시 형태를 바꿀 것)

- 1. What is the **p** \_\_\_\_\_ cause of global warming?
- 2. Parents travel abroad with children to give them **e** \_\_\_\_\_ to other cultures.
- 3. In the wild, animals often show **a** \_\_\_\_\_ to protect their territory.

## Exercise 8

## 빈칸 추론

다음 빈칸에 들어갈 말로 가장 적절한 것은?

25007-0008

One might ask why having a conversation on a mobile phone while driving is so much more disruptive than, for example, having a conversation with a passenger in the car. A likely reason is the \_\_\_\_\_ when having a mobile phone conversation. A passenger in the car will pick up from non-verbal cues that the driver needs to concentrate on the main task of driving at times when the latter becomes tricky. A remote interlocutor is much less likely to pick up these cues and therefore will continue to make cognitively demanding conversation at a time when the secondary task needs to be shut down to devote resources to the main driving task. A cognitively demanding conversation, especially one over which the driver has little or no control in terms of dynamically adjusting his or her allocation of cognitive resources, appears to interfere with computation of speeds, distances and widths as required by the driving task, probably as a result of diminished attention to sensory inputs. Use of a mobile phone also demands other secondary tasks, such as inputting of a telephone number on the keypad, which would also tend to interfere with the main driving task.

\* interlocutor: 대화자

- ① influence of background noise
- ② loss of control over the situation
- ③ dependency on network reliability
- ④ inhibition of immediate interaction
- ⑤ difficulty in interpreting verbal cues

## Sentence Structure

- A passenger in the car will pick up from non-verbal cues [that the driver needs to concentrate on the main task of driving] at times [when the latter becomes tricky].

첫 번째 [ ]는 pick up의 목적어 역할을 하는 명사절이고, 두 번째 [ ]는 times를 수식하는 관계절이다.

**Word Search** 주어진 문장에 들어갈 적절한 영어 단어를 본문에서 찾아 쓰시오. (필요시 형태를 바꿀 것)

1. The loud music was a d \_\_\_\_\_ influence on the students taking the exam.
2. His raised eyebrow was a c \_\_\_\_\_ that he was uncertain about the plan.
3. Please try to c \_\_\_\_\_ fully on what the teacher is saying.

**Exercise 9** 빈칸 추론

다음 빈칸에 들어갈 말로 가장 적절한 것은?

25007-0009

Firms often bundle goods or services for convenience or marketing purposes. Shoe vendors could sell lefts and rights separately but nearly all consumers would rather buy the bundle. Bundling can \_\_\_\_\_ when consumers have imperfectly correlated preferences for related goods. For example, cable television services usually offer a wide range of programming, including channels that specialize in sports, food, drama, and news. Cable services could allow their customers to purchase channels “a la carte” — sports fans could purchase just the sports channels, and so forth. But cable services instead set a single bundled price that is not too much more than individual a la carte prices. (For example, the price for the “sports+food+drama+news” bundle is not much more than the price the service would charge for the sports package alone.) Since the cable service has essentially zero marginal cost of selling the bundle, this practice helps increase its profits.

\* vendor: 판매 회사 \*\* a la carte: 따로 골라

\*\*\* marginal cost: 한계 비용(생산물 한 단위를 추가로 생산할 때 필요한 총비용의 증가분)

- ① also help sellers extract higher profits
- ② lead to more efficient resource allocation
- ③ nonetheless increase confusion for customers
- ④ sometimes create dissatisfaction with bundled products
- ⑤ facilitate better matching of products to consumer needs

**Sentence Structure**

- But cable services instead set a single bundled price [that is not too much more than individual a la carte prices].

[ ]는 a single bundled price를 수식하는 관계절이다.

**Word Search**

주어진 문장에 들어갈 적절한 영어 단어를 본문에서 찾아 쓰시오. (필요시 형태를 바꿀 것)

1. We extended online ordering options for the **c** \_\_\_\_\_ of our customers.
2. Investors are always seeking opportunities to maximize their **p** \_\_\_\_\_ in the stock market.
3. The lawyer chose to **s** \_\_\_\_\_ in human rights law to fight for freedom and justice.

## Exercise 10 빈칸 추론

다음 빈칸에 들어갈 말로 가장 적절한 것은?

25007-0010

Many studies have shown that the brain cannot recognize the difference between a well-imagined experience and the real thing. Try this experiment. Imagine that you have a beautiful juicy yellow lemon in your hand. Imagine yourself slicing the lemon in half and looking at the juicy circle of the lemon. Now, imagine yourself biting into the lemon. If you are like many people, you begin to salivate. You may feel some tightness in your throat from the sourness. But you can see that since there is no real lemon, you are having a physiological reaction to an imagined experience. So, too, with organizing; the more vividly you can imagine arriving on time in a calm, relaxed fashion, the more your body receives signals from your brain that it is a true experience. Through visualizing, \_\_\_\_\_.

\* salivate: 침이 나오다 \*\* physiological: 생리적인

- ① you are practicing for reality
- ② the brain absorbs new information better
- ③ you are challenging conventional thinking
- ④ the ability to discern falsehood is developed
- ⑤ you control your instinct to jump to conclusions

### Sentence Structure

- So, too, with organizing; **the more vividly** you can imagine arriving on time in a calm, relaxed fashion, **the more** your body receives signals from your brain [that it is a true experience].

‘~할수록 더 ...하다’라는 의미의 「the + 비교급 ~, the + 비교급 ...」 구문이 쓰이고 있다. [ ]는 signals의 내용을 설명하는 동격절이다.

**Word Search** 주어진 문장에 들어갈 적절한 영어 단어를 본문에서 찾아 쓰시오. (필요시 형태를 바꿀 것)

1. My mother is **s** \_\_\_\_\_ vegetables into small pieces to add them to the soup.
2. His **r** \_\_\_\_\_ to the news of his promotion was a mix of surprise and delight.
3. I **v** \_\_\_\_\_ remember the warmth of the sun as if it were yesterday.

## Exercise 11 빈칸 추론

다음 빈칸에 들어갈 말로 가장 적절한 것은?

25007-0011

In addition to changing a hypothesis by being more specific about which amounts of one variable had what effect, you can change a hypothesis by being more specific about \_\_\_\_\_ . Thus, if your hypothesis involves a general construct, you may be able to improve your hypothesis by breaking that multidimensional construct down into its individual dimensions and then making hypotheses involving those individual components. For example, rather than hypothesizing that love will increase over time, you might hypothesize that certain aspects of love (commitment, intimacy) will increase over time, whereas other parts (passionate love) will not. Similarly, rather than saying that stress will interfere with memory, you might try to find what part of memory is most affected by stress. Is it encoding, rehearsal, organization, or retrieval? The component strategy has paid off for social psychologists who have broken down prejudice into its conscious and unconscious dimensions and for personality psychologists who have broken down global (overall) self-esteem into different types (body self-esteem, academic self-esteem, social self-esteem, etc.).

\* retrieval: (기억한 내용의) 인출, 상기 \*\* self-esteem: 자존감

- ① which aspect of a variable had what effect
- ② what other variables have the same impact
- ③ the role of sample size in identifying key variables
- ④ what methodology was used to measure a variable
- ⑤ the cultural and historical background of a variable

### Sentence Structure

- The component strategy has paid off [for social psychologists {who have broken down prejudice into its conscious and unconscious dimensions}] and [for personality psychologists {who have broken down global (overall) self-esteem into different types (body self-esteem, academic self-esteem, social self-esteem, etc.)}]. 두 개의 [ ]는 and로 대등하게 연결되어 paid off에 이어지며, 첫 번째 { }는 social psychologists를, 두 번째 { }는 personality psychologists를 수식하는 관계절이다.

**Word Search** 주어진 문장에 들어갈 적절한 영어 단어를 본문에서 찾아 쓰시오. (필요시 형태를 바꿀 것)

1. He conducted a study to determine if diet could be a **v** \_\_\_\_\_ affecting mood.
2. Environmental issues have political **d** \_\_\_\_\_, which means they often involve government policies.
3. She realized her **p** \_\_\_\_\_ against people with disabilities was unfair.

## Exercise 12 함축 의미 추론

밑줄 친 a duck pond가 다음 글에서 의미하는 바로 가장 적절한 것은?

25007-0012

Most organizations and leaders get into trouble in the implementation phase of the leadership process. With self-serving leaders at the helm, the traditional hierarchical pyramid is kept alive and well. When that happens, who do people think they work for? The people above them. The minute you think you work for the person above you for implementation, you are assuming that person — your boss — is *responsible* and your job is being *responsive* to that boss and to his or her whims or wishes. Now “boss watching” becomes a popular sport and people get promoted on their upward-influencing skills. As a result, all the energy of the organization is moving up the hierarchy, away from customers and the frontline folks who are closest to the action. What you get is a duck pond. When there is a conflict between what the customers want and what the boss wants, the boss wins. You have people quacking like ducks: “It’s our policy.” “I just work here.” “Would you like me to get my supervisor?”

\* at the helm: 주도권을 잡은 \*\* whim: 변덕 \*\*\* quack: 꺽꺽거리다

- ① a company which appears peaceful but has hidden challenges posed by customers
- ② a company where the boss emphasizes a sense of belonging and tries to eliminate any conflict
- ③ an organization where the boss intensifies competition among employees for higher productivity
- ④ an organization filled with employees who prioritize pleasing their superiors over serving customers
- ⑤ an organization where the employees imitate their boss by doing repetitive tasks without questioning

### Sentence Structure

- **The minute** you think you work for the person above you for implementation, you are assuming [{that person — your boss — is *responsible*} and {your job is being *responsive* to that boss and to his or her whims or wishes}].

The minute은 as soon as(~하는 순간, ~하자마자)의 의미를 지닌다. [ ]는 assuming의 목적어 역할을 하는 명사절이고, 그 안에서 두 개의 { }가 and로 대등하게 연결되어 있다.

**Word Search** 주어진 문장에 들어갈 적절한 영어 단어를 본문에서 찾아 쓰시오. (필요시 형태를 바꿀 것)

1. Never **a** \_\_\_\_\_ someone’s intentions without clear communication.
2. A good leader is always **r** \_\_\_\_\_ to employees’ needs and suggestions.
3. The **c** \_\_\_\_\_ between the two countries evolved into a full-scale war.

**Exercise 1** 빈칸 추론

다음 빈칸에 들어갈 말로 가장 적절한 것은?

25007-0013

We are able to speak and comprehend language with great skill despite its quasiregularity — indeed, because of it. Communication requires shared knowledge, and so languages must be systematic rather than arbitrary. However, the demands of comprehending and producing language require additional \_\_\_\_\_ because speakers produce forms that deviate from standard patterns and listeners must be able to comprehend them. Many shortcuts that promote fluent speech eventually enter the language, such as “gonna,” “hafta,” and “tryna,” which partially overlap with the source words. The product of these conflicting pressures is quasiregularity. These patterns can be mastered with extensive practice, which is easy to obtain if you’ve grown up speaking a language and become a fluent reader. Mastering stress patterns is much harder for people learning English as a second language, who often exhibit “stress deafness.”

\* quasiregularity: 준규칙성 \*\* arbitrary: 자의적인 \*\*\* deviate from: ~에서 벗어나다

- ① flexibility
- ② security
- ③ integration
- ④ authorization
- ⑤ documentation

**Sentence Structure**

- Many shortcuts [that promote fluent speech] eventually enter the language, such as “gonna,” “hafta,” and “tryna,” [which partially overlap with the source words].

첫 번째 [ ]는 Many shortcuts를 수식하는 관계절이고, 두 번째 [ ]는 “gonna,” “hafta,” and “tryna”를 부가적으로 설명하는 관계절이다.

**Word Search** 주어진 문장에 들어갈 적절한 영어 단어를 본문에서 찾아 쓰시오. (필요시 형태를 바꿀 것)

1. She stood staring at the accident, unable to c \_\_\_\_\_.
2. He studied five foreign languages but is f \_\_\_\_\_ in only three of them.
3. Football season o \_\_\_\_\_ the baseball season in September.

## Exercise 2

## 빈칸 추론

다음 빈칸에 들어갈 말로 가장 적절한 것은?

25007-0014

You know how people always tell you to “think outside the box”? Well, I hate that expression. I get the broader meaning of the phrase: to look for unexpected solutions that defy convention. Nothing wrong with that. But to me, advertising is all about thinking INSIDE the box. And advertising is full of boxes — or limitations, frameworks, and concrete realities. The budget is a box. The dimensions of the page are a box. The ingredients in the product are a box. The most important box of all is the strategy. If you can come up with a great creative idea that fits within the confines of the strategy, then you’re a genius. Come up with a great idea that’s wildly off the mark and NOT strategic, then you’re an artist, not an advertiser. This is not to say that you can’t wail against the box. Or try to change the dimensions of the box. But at its very essence, advertising can only truly be advertising when it is \_\_\_\_\_. The cleverest among us realize that the greatest fun of advertising is seeing how far we can go with an idea, an execution, a new media placement and *still be in the box*.

\* defy: ~에 도전하다 \*\* confines: 제한, 한계 \*\*\* wail: 투덜대다

- ① breaking new ground
- ② experience of an audience
- ③ a clear outgrowth of the box
- ④ inspired by other types of boxes
- ⑤ a challenge to existing conventions

## Sentence Structure

- The cleverest among us realize [that the greatest fun of advertising is {seeing <how far we can go with an idea, an execution, a new media placement and *still be in the box*>}].

[ ]는 realize의 목적어 역할을 하는 명사절이고, { }는 주격 보어이다. < >는 seeing의 목적어 역할을 하는 명사절이다.

**Word Search** 주어진 문장에 들어갈 적절한 영어 단어를 본문에서 찾아 쓰시오. (필요시 형태를 바꿀 것)

1. “It’s only a suspicion,” the police officer said, “nothing **c**\_\_\_\_\_.”
2. The family struggle to balance their household **b**\_\_\_\_\_.
3. Einstein was a mathematical **g**\_\_\_\_\_.

**Exercise 3** 빈칸 추론

다음 빈칸에 들어갈 말로 가장 적절한 것은?

25007-0015

Life on our planet can be arranged, more or less, into autotrophs and heterotrophs, organisms that exploit energy from the sun or chemical reactions, and organisms that take energy from those who've already captured it. What is unusual about our species is that we've been able to use more and more energy without having to evolve into a different species. We've achieved this through a combination of social learning, complex culture, and technologies. We don't have to speciate to gain the claws of an allosaurus; we can share information to design a warhead or a power station. In other words, we \_\_\_\_\_. Fire and spears did the trick for hundreds of thousands of years, until we devised the domestication of our food sources. The next big shift came in the mechanisation of processes that gave us the Industrial Revolution. This enabled us to draw ancient deposits of organic energy out of the Earth and burn them.

\* speciate: 새로운 종으로 분화하다 \*\* allosaurus: 알로사우루스(육식 공룡) \*\*\* warhead: 탄두

- ① spoil every frontier we encounter
- ② evolve to deal with long-term threats
- ③ are unlikely to use our tools optimally
- ④ change our tools rather than our bodies
- ⑤ leave genetic information everywhere we go

**Sentence Structure**

- Life on our planet can be arranged, more or less, into autotrophs and heterotrophs, [organisms {that exploit energy from the sun or chemical reactions}, and organisms {that take energy from those <who've already captured it>}].

[ ]는 autotrophs and heterotrophs와 동격 관계에 있는 명사구이다. 두 개의 { }는 각각 바로 앞에 있는 organisms를 수식하는 관계절이다. < >는 those를 수식하는 관계절이다.

**Word Search** 주어진 문장에 들어갈 적절한 영어 단어를 본문에서 찾아 쓰시오. (필요시 형태를 바꿀 것)

1. Many companies are coming to e \_\_\_\_\_ the natural resources.
2. A new system has been d \_\_\_\_\_ to control the air pollution in the city.
3. The region has many d \_\_\_\_\_ of valuable oil.

## Exercise 4 빈칸 추론

다음 빈칸에 들어갈 말로 가장 적절한 것은?

25007-0016

Media institutions across the globe are facing multiple crises: of funding, trust, representation, accountability and legitimacy. In many of the countries that make up capitalism's core, the newspaper and magazine industry is in serious decline as large digital intermediaries take over the majority of advertising revenue. Much of the debate about the sustainability of the news industry circulates around debates relating to this 'broken business model'. Local news in particular is increasingly under threat. In the UK, the majority of the population (57.9%) is no longer served by a local daily newspaper. To retain high levels of profitability, media corporations have closed or merged titles and cut jobs, often moving journalists long distances away from the communities they serve and no longer being able to provide content of relevance to them. In short, a profit-driven response means \_\_\_\_\_.

\* legitimacy: 합법성 \*\* intermediary: 중개업체, 중개자 \*\*\* revenue: 수익

- ① media become ever more unsustainable
- ② media have plenty of mistakes to point to
- ③ strengthening the journalists' social responsibility
- ④ improved sales revenue leads to editorial independence
- ⑤ improving the quality and availability of news and information

### Sentence Structure

- In many of the countries [that make up capitalism's core], the newspaper and magazine industry is in serious decline [as large digital intermediaries take over the majority of advertising revenue].

첫 번째 [ ]는 the countries를 수식하는 관계절이다. 두 번째 [ ]는 접속사 as가 이끄는 부사절이다.

**Word Search** 주어진 문장에 들어갈 적절한 영어 단어를 본문에서 찾아 쓰시오. (필요시 형태를 바꿀 것)

1. She suffered m \_\_\_\_\_ injuries in the crash.
2. This issue has no r \_\_\_\_\_ to the current situation.
3. Efficient processes need to be introduced to increase p \_\_\_\_\_.

**Exercise 5** 빈칸 추론

다음 빈칸에 들어갈 말로 가장 적절한 것은?

25007-0017

The complexity of human intervention in nature means that the ecosystems have had to adapt — or in many cases die out. Ancient woodland exists only in small pieces in Britain now. Many of these remnants are enclosed in nature reserves and national parks. They need specific protection. New habitats have been created with their own ecosystems. The urbanization of the landscape and the creation of road and railway corridors have given us the garden habitats that many species thrive in. Motorway roadsides with higher salt deposits support salt-loving plants otherwise found along the coast. Roads provide abundant road-kill for scavengers. These may be poor substitutes for what they replace, but they are habitats that can add more if properly managed. The natural environment we may seek to conserve is the natural environment \_\_\_\_\_.

\* remnant: (보통 복수로) 잔존물 \*\* corridor: 회랑, 좁고 긴 통로 \*\*\* scavenger: 죽은 동물을 먹는 동물

- ① we have in part created
- ② surviving would be a test
- ③ that have not yet been negatively affected
- ④ we are destroyed by planting exotic species
- ⑤ that attracts attention without requiring effort

**Sentence Structure**

- [The urbanization of the landscape] and [the creation of road and railway corridors] have given us the garden habitats [that many species thrive in].

첫 번째와 두 번째 [ ]가 and로 연결되어 문장의 주어를 구성한다. 세 번째 [ ]는 the garden habitats를 수식하는 관계절이다.

**Word Search**

주어진 문장에 들어갈 적절한 영어 단어를 본문에서 찾아 쓰시오. (필요시 형태를 바꿀 것)

1. The rate of u \_\_\_\_\_ is the challenge facing cities of the future.
2. His yard is e \_\_\_\_\_ with iron railings.
3. Many countries have to find s \_\_\_\_\_ s for coal to protect the earth.

## Exercise 6 함축 의미 추론

25007-0018

밑줄 친 the code that has been programmed into your mind가 다음 글에서 의미하는 바로 가장 적절한 것은?

For most of us, our minds have been programmed by a combination of factors — our friends, our parents, the mass media, and advertisers. Some of these agents of programming truly know you and have your best interests in mind as they reinforce your special strengths and help you overcome your troublesome weaknesses; they are trying to make you happier and make your life better. Other agents of programming are trying to use you as a tool to achieve their goals, which are often very different from your own goals. When this occurs, the programming makes you less and less happy as they “help” you solve problems you don’t have and make worse the problems you do have. When you allow others to dominate the programming of your mind, then when your mind runs on automatic pilot, you end up behaving in ways that achieve the goals of those programmers rather than behaving in ways that would make you happier. Therefore, it is important that you periodically examine the code that has been programmed into your mind.

- ① the prejudices you hold against others
- ② the core means to achieve your objectives
- ③ the methods to enhance your brain activity
- ④ the qualities that tell true friends from pretenders
- ⑤ the influence others have on your thinking and acting

### Sentence Structure

- When this occurs, the programming makes you less and less happy [as they “help” you solve problems {you don’t have} and make worse the problems {you do have}].

[ ]는 이유를 나타내는 부사절이다. 두 개의 { }는 각각 바로 앞에 있는 problems와 the problems를 수식하는 관계절이다.

**Word Search** 주어진 문장에 들어갈 적절한 영어 단어를 본문에서 찾아 쓰시오. (필요시 형태를 바꿀 것)

1. Such jokes tend to r\_\_\_\_\_ harmful stereotypes.
2. She needed surgery to cure a t\_\_\_\_\_ foot injury.
3. It’s important to know your own strengths and w\_\_\_\_\_.

Exercise 7 빈칸 추론

다음 빈칸에 들어갈 말로 가장 적절한 것은?

25007-0019

We tend to underestimate the \_\_\_\_\_ of oral cultures. We're all familiar with the children's game in which a message is whispered from one person to another until it goes around a room. The message invariably gets distorted — sometimes with hilarious results — when the original message and the final message are compared. But this is misleading. When it is important, oral cultures can accurately transmit information across long distances and through generations. For example, American author Alex Haley was able to discover an oral record of his ancestors in Africa, and his search is described in the 1976 book, *Roots: The Saga of an American Family*. Similarly, the *Odyssey* and *Iliad* were originally heroic oral histories of Greek culture that were only written down many centuries after they were composed.

\* hilarious: 아주 재미있는

- ① creativity
- ② subtleness
- ③ immediacy
- ④ complexity
- ⑤ effectiveness

Sentence Structure

- [When it is important], oral cultures can accurately transmit information [{across long distances} and {through generations}].  
 첫 번째 [ ]는 시간의 부사절이고, 두 번째 [ ]에서 전치사구인 두 개의 { }가 and로 대등하게 연결되어 있다.

Word Search

주어진 문장에 들어갈 적절한 영어 단어를 본문에서 찾아 쓰시오. (필요시 형태를 바꿀 것)

1. Many generations ago, my **a** \_\_\_\_\_ arrived in these lands, leaving behind a legacy of courage and adventure.
2. The pianist **c** \_\_\_\_\_ a famous piece of music that is still celebrated today.
3. The headline was **m** \_\_\_\_\_, giving a false impression of what the article was about.

## Exercise 8 빈칸 추론

다음 빈칸에 들어갈 말로 가장 적절한 것은?

25007-0020

Emotions meet the criteria of being \_\_\_\_\_. Take, for example, two animals squaring off in a fight over food. As they prepare to lock horns, literally or figuratively, their intense feelings prompt a repertoire of bodily reactions. When an animal's back arches and its hair stands on end, it appears larger and stronger. When it bares its teeth, frowns its brows, makes fierce noises, or displays its horns, it signals to the other animal that fighting such a strong adversary may not be worth it. These signals — displays of aggression — directly improve the chances that the other animal will withdraw, thus preventing violence and avoiding potential injury or death. Sending these signals benefits the species, as does the ability to interpret these messages. It's a win-win.

\* square off: 싸울 자세를 취하다 \*\* lock horns: 뿔을 맞대다. 다투다

- ① selfish tendencies
- ② injurious responses
- ③ aggressive instincts
- ④ information sources
- ⑤ advantageous adaptations

### Sentence Structure

- These signals — displays of aggression — directly improve the chances [that the other animal will withdraw], thus [{preventing violence} and {avoiding potential injury or death}].

첫 번째 [ ]는 the chances의 내용을 구체적으로 설명하는 동격절이다. 두 번째 [ ]는 these signals를 의미상의 주어로 하는 분사구문인데, 그 안에서 두 개의 분사구문인 { }는 and로 연결되어 앞 절의 결과적인 상황을 나타낸다.

**Word Search** 주어진 문장에 들어갈 적절한 영어 단어를 본문에서 찾아 쓰시오. (필요시 형태를 바꿀 것)

1. The job applicants were evaluated based on strict c \_\_\_\_\_.
2. They began to p \_\_\_\_\_ for the storm by securing their homes.
3. The news about the company p \_\_\_\_\_ him to return to the office immediately.

**Exercise 9** 빈칸 추론

다음 빈칸에 들어갈 말로 가장 적절한 것은?

25007-0021

With the construction and furnishing of interior space from the fifteenth to the seventeenth century, Italians created a world in which they could develop a different style of life and in which a new culture came to be defined. This is why so much was spent on objects, why so many new kinds of objects came into existence, why the arts flourished now in the domestic world as they had earlier in the ecclesiastical world. Consumption was a creative force to construct a cultural identity. In inventing all kinds of new furnishings ranging from pottery to paintings, in elaborating their forms, in refining their production, and in organizing them into new spatial arrangements within their homes, Italians discovered new values and pleasures for themselves, reordered their lives with new standards of comportment, communicated something about themselves to others — in short, generated culture, and in the process created identities for themselves. In this cultural development there was a dynamic for change that resulted from \_\_\_\_\_.

\* ecclesiastical: 종교의 \*\* comportment: 품위, 처신

- ① the pursuit of innovation and modernity
- ② the establishment of social classes by wealth
- ③ the intentional and systematic education of culture
- ④ the interaction between people and physical objects
- ⑤ the increasing recognition of the importance of arts

**Sentence Structure**

- With the construction and furnishing of interior space from the fifteenth to the seventeenth century, Italians created a world [in which they could develop a different style of life] and [in which a new culture came to be defined].

두 개의 [ ]는 and로 연결되어 선행하는 a world를 수식하는 관계절이다.

**Word Search** 주어진 문장에 들어갈 적절한 영어 단어를 본문에서 찾아 쓰시오. (필요시 형태를 바꿀 것)

1. In the Renaissance era, art **f** \_\_\_\_\_, giving rise to some celebrated masterpieces.
2. Engineers worked tirelessly to **c** \_\_\_\_\_ the new bridge.
3. The policies aimed at reducing energy **c** \_\_\_\_\_ have led to environmental benefits.

## Exercise 10 빈칸 추론

다음 빈칸에 들어갈 말로 가장 적절한 것은?

25007-0022

The distribution of US farm homesteads granted to pioneer settlers is a classic case of \_\_\_\_\_. Properties were allocated based on surveys with regular north-south and east-west boundaries, regardless of the lay of the land. This meant boundaries of homesteads were unrelated to boundaries of watersheds. Some homesteads were high and dry. Others were lower and wetter, but subject to flooding. Downstream landowners could not control erosion and runoff from upstream properties. Thus, an uphill landowner's effects on the environment could harm another landowner downhill, but the lower landowner had no options. These nineteenth-century decisions have consequences to this day. For example, one of the most challenging problems for Austin College's Sneed grassland restoration is erosive flash-flood runoff from poorly managed upstream properties.

\* homestead: (개척 시대에 미국 정부가 정착민에게 지급한) 자영 농지 \*\* watershed: (강의) 유역  
\*\*\* runoff: (땅속으로 흡수되지 않고 흐르는) 유수(流水)

- ① shifting boundaries depending on the interests of pioneers
- ② land boundaries reflecting the boundaries along the waterways
- ③ conflicts between the natives and the pioneers over the boundaries
- ④ ineffective setting of boundaries according to natural boundaries
- ⑤ artificial boundaries not matching natural boundaries

### Sentence Structure

- This meant [boundaries of homesteads were unrelated to boundaries of watersheds].  
[ ]는 that이 생략된 명사절로 meant의 목적어 역할을 한다.

**Word Search** 주어진 문장에 들어갈 적절한 영어 단어를 본문에서 찾아 쓰시오. (필요시 형태를 바꿀 것)

1. The charity decided to **g** \_\_\_\_\_ money for disaster relief efforts.
2. The **p** \_\_\_\_\_ faced numerous challenges while settling the new territory.
3. The manager must **a** \_\_\_\_\_ tasks efficiently to meet the deadline.

**Exercise 11** 빈칸 추론

다음 빈칸에 들어갈 말로 가장 적절한 것은?

25007-0023

Publication bias means that the size of an effect could be overstated for many behavioral phenomena reported in the peer-reviewed literature. For example, suppose you read a few studies showing that a new behavioral therapy for depression significantly reduces symptoms of depression in patients. If a researcher tests the effectiveness of this same behavioral therapy and finds no effect, it is likely that no peer-reviewed journal will accept the manuscript, so you will never find it or read about it. It is therefore possible that the effectiveness of this therapy is overstated because studies failing to show an effect are not included in the published peer-reviewed literature. Researchers stated that “scientific progress is made by trusting the bulk of current knowledge,” and the publication bias compromises this trust. Keep in mind that while positive results reported in the peer-reviewed literature can certainly be trusted, also take caution in knowing that \_\_\_\_\_.

\* publication bias: 출판 편향(실험이나 연구 결과가 출판이나 배포 여부에 영향을 미치는 것)

- ① the literature can be based just on a single experiment
- ② many negative results may not be included in your search
- ③ prejudice can lead to any outcome being interpreted as the opposite
- ④ the conditions of the experiment may have been intentionally altered
- ⑤ the next edition of the literature could reveal entirely different results

**Sentence Structure**

- Publication bias means [that the size of an effect could be overstated for many behavioral phenomena {reported in the peer-reviewed literature}].

[ ]는 that이 이끄는 명사절로 means의 목적어 역할을 하고, 그 안의 { }는 many behavioral phenomena를 수식하는 분사구이다.

**Word Search** 주어진 문장에 들어갈 적절한 영어 단어를 본문에서 찾아 쓰시오. (필요시 형태를 바꿀 것)

1. After his injury, he attended physical t \_\_\_\_\_ sessions twice a week.
2. She decided to a \_\_\_\_\_ the job offer, excited about the new opportunities.
3. The new advertising campaign had an immediate e \_\_\_\_\_ on sales.

## Exercise 12 함축 의미 추론

25007-0024

밑줄 친 employed in a prison industry — consuming the world가 다음 글에서 의미하는 바로 가장 적절한 것은?

Relying on economic growth to overcome economic problems suffers a positive feedback pitfall. Governments encourage increased economic production as a means of lifting the poor out of poverty and satisfying the demands of the rich, but the appeal of the resulting new products creates new wants that get satisfied with new income generated from yet more production. In other words, people work to earn money to satisfy wants (and of course needs), but their effort results in production of goods, including new innovations, that, when marketed, increase others' desires. Those others then work to satisfy their new wants, producing yet more goods marketed to others, and so on in a positive feedback that grinds away at the planet's stock of resources and generates more waste and new types of wastes whose consequences we only partially understand. Reflecting on this circumstance, the wise gorilla Ishmael in Daniel Quinn's novel of the same name describes modern humans as prisoners of a mother culture, employed in a prison industry — consuming the world.

\* pitfall: (숨겨진) 함정, 위험

- ① stuck in overproduction that exceeds consumer demand
- ② caught in a scenario where the law of the jungle applies
- ③ engaged in corporate competition for market dominance
- ④ trapped in an endless cycle of consumption and resource exhaustion
- ⑤ oppressed in a government-controlled economy where freedom is deprived

### Sentence Structure

- Governments encourage increased economic production as a means of [lifting the poor out of poverty] and [satisfying the demands of the rich], but the appeal of the resulting new products creates new wants [that get satisfied with new income generated from yet more production].

첫 번째와 두 번째 [ ]는 동명사구로 and로 연결되어 전치사 of의 목적어 역할을 하고, 세 번째 [ ]는 선행하는 new wants를 수식하는 관계절이다.

**Word Search** 주어진 문장에 들어갈 적절한 영어 단어를 본문에서 찾아 쓰시오. (필요시 형태를 바꿀 것)

1. By delivering high-quality work, he managed to e \_\_\_\_\_ a promotion.
2. To s \_\_\_\_\_ the safety regulations, the manufacturer upgraded their equipment.
3. I \_\_\_\_\_ drives industries to evolve and adapt to new challenges.

**Exercise 1** 빈칸 추론

다음 빈칸에 들어갈 말로 가장 적절한 것은?

25007-0025

What is said is never a \_\_\_\_\_. Even if one agrees word for word with something that has been said before, everything — the world, the speaker, the circumstances, the addressee, and the meaning of what was said — has changed. What one says is therefore in each case unique. Although most of our statements are unoriginal, they show through their particular, even unique, style (which can be dull, ugly, or trivial) that someone has appropriated and therewith personalized them. Every sentence proves that the author has changed a received gift into a thought of her own. An analysis of what is one's own might then reveal much of what the speaker has borrowed from parents, guides, friends, books, fashions, etc., while at the same time disclosing how all these influences have converged into the unique results of what the author said.

\* trivial: 진부한 \*\* therewith: 그와 함께 \*\*\* converge: 한데 모이다

- ① hidden truth
- ② mere repetition
- ③ biased statement
- ④ genuine discovery
- ⑤ precise representation

**Sentence Structure**

- [Even if one agrees word for word with something {that has been said before}], everything — the world, the speaker, the circumstances, the addressee, and the meaning of [what was said] — has changed.  
 첫 번째 [ ]는 Even if가 이끄는 양보의 의미를 지닌 부사절이며, 그 안의 { }는 something을 수식하는 관계절이다. 두 번째 [ ]는 전치사 of의 목적어 역할을 하는 명사절이다.

**Word Search**

주어진 문장에 들어갈 적절한 영어 단어를 본문에서 찾아 쓰시오. (필요시 형태를 바꿀 것)

1. Under the current c \_\_\_\_\_, the company needs to ensure the safety of all employees.
2. This species has a u \_\_\_\_\_ song that is distinct from all other species.
3. His facial expression had r \_\_\_\_\_ his true feelings, despite his attempt to conceal them.

## Exercise 2 빈칸 추론

다음 빈칸에 들어갈 말로 가장 적절한 것은?

25007-0026

Worry is often \_\_\_\_\_. In a world marred by uncertainty, doubt continuously swirling around you, a question rises to the surface of your awareness. And in that moment of recognition, you might choose to solve the mystery. You engage in worrying, hoping against hope that you'll finally nail down the unsolvable questions troubling your life. Uncertainty, or rather, the impatience with uncertainty, is a common thread running through many aspects of worrying. The quest for a neat and satisfying resolution frequently drives this behavior. It's understandable — it's likely born out of a tireless commitment to do better, driven by a willingness to pursue the important things in your life — but worrying begins to deviate from that path. Despite your good intentions, you get trapped in thought rather than called to action.

\* mar: 손상시키다 \*\* swirl: 소용돌이치다 \*\*\* deviate: 벗어나다

- ① the realization of one's intentions
- ② the recognition of incompleteness
- ③ hesitation in acknowledging others' perfection
- ④ a reluctance to take action in the face of uncertainty
- ⑤ prioritizing important matters over controlling uncertainty

### Sentence Structure

- [Uncertainty, **or rather**, the impatience with uncertainty], is a common thread [running through many aspects of worrying].

첫 번째 [ ]는 문장의 주어부로, 그 안의 or rather는 '더 정확하게는'이라는 의미이다. 두 번째 [ ]는 a common thread를 수식하는 분사구이다.

**Word Search** 주어진 문장에 들어갈 적절한 영어 단어를 본문에서 찾아 쓰시오. (필요시 형태를 바꿀 것)

1. He expressed significant **d** \_\_\_\_\_ about their claims.
2. The child's **i** \_\_\_\_\_ was clearly shown as he kept asking when they would arrive.
3. Her devoted **c** \_\_\_\_\_ to volunteering has made a notable difference in the community.

**Exercise 3** 빈칸 추론

다음 빈칸에 들어갈 말로 가장 적절한 것은?

25007-0027

In the early days of the commercial internet, scholars discovered that, in cyberspace, computer code operated as a kind of ‘law’. Not law as we know it — public rules decided by legislators and judges — but a different kind of law, embedded in the tech itself. Whenever we use an app, platform, smartphone or computer, we have no choice but to follow the strict rules that are coded into these technologies. Some rules are commonplace, like the rule that *you cannot access this system without the correct password*. Hence the young man who lost more than \$200 million because he couldn’t remember the password to his virtual currency wallet. Other rules are more controversial. In late 2020, one social media platform made it impossible for users to share a controversial article containing allegations of corruption about a public figure’s son, on the basis that it violated the platform’s rules against sharing hacked material. As more and more of our actions, interactions and transactions are mediated through digital technology, those who write code increasingly \_\_\_\_\_. Software engineers are becoming social engineers.

\* embedded: 내장된 \*\* allegation: 혐의, 주장

- ① need to make a conscious effort to advance their skills
- ② focus exclusively on improving the website platform
- ③ depend on legal principles to regulate coding rules
- ④ write the rules by which the rest of us live
- ⑤ exercise less power over societal norms

**Sentence Structure**

- Whenever we use an app, platform, smartphone or computer, we **have no choice but to follow** the strict rules [that are coded into these technologies].

'have no choice but to + 동사원형'은 '~할 수밖에 없다'라는 의미이다. [ ]는 the strict rules를 수식하는 관계절이다.

**Word Search**

주어진 문장에 들어갈 적절한 영어 단어를 본문에서 찾아 쓰시오. (필요시 형태를 바꿀 것)

1. The **l** \_\_\_\_\_ proposed a new plan aimed at reforming healthcare.
2. The new policy proved to be **c** \_\_\_\_\_, sparking heated debates across social media platforms.
3. When you **v** \_\_\_\_\_ the law, you will face severe penalties, including fines.

## Exercise 4 빈칸 추론

다음 빈칸에 들어갈 말로 가장 적절한 것은?

25007-0028

It wasn't really until the late '70s and early '80s that the concept of brands began to extend into all areas of business. As entities were privatized, markets opened up and competition became fiercer, so the need to differentiate your business became greater. Utilities, telecoms providers, banks, insurance companies and airlines were all now enthusiastically embracing the power of branding. As brand owners fought for space in your mind, advertising became incredibly influential. The focus was on imbuing products and services with meaning so that you as the customer could surround yourself with the brands that best represented you — the very notion of shopping as a form of personal expression. Even businesses serving other businesses began to realize that having a brand was an important business support. Brands were now seen as more than just a logo or a tagline; they were \_\_\_\_\_.

\* entity: 기업 \*\* imbue: 불어넣다, 가득 채우다

\*\*\* tagline: 태그라인(기업, 브랜드 등에 꼬리표처럼 따라붙는 함축적 단어나 짧은 문구)

- ① seen as opportunities to create meaning
- ② becoming key to justifying a premium price
- ③ starting to focus on creating sustainable products
- ④ recognized as effective ways to boost employee spirits
- ⑤ reflected in customer satisfaction tied to functional benefits

### Sentence Structure

- **It wasn't** really **until** the late '70s and early '80s **that** the concept of brands began to extend into all areas of business.

「It was not until ~ that ...」은 '~이 되어서야 비로소 ...했다'의 의미이다.

**Word Search** 주어진 문장에 들어갈 적절한 영어 단어를 본문에서 찾아 쓰시오. (필요시 형태를 바꿀 것)

1. The intense **c** \_\_\_\_\_ between the two companies pushed them to innovate rapidly.
2. The philosopher's **i** \_\_\_\_\_ writings have shaped the way people think about modern philosophy.
3. The **n** \_\_\_\_\_ of equality is fundamental to the principles of democracy.

**Exercise 5** 빈칸 추론

다음 빈칸에 들어갈 말로 가장 적절한 것은?

25007-0029

There are many ordinary, daily-life situations like the following example. A straight stick put in water looks bent; yet we do not believe it has become bent just because it was immersed in water, which is an easily penetrable liquid. Railroad tracks seem to converge in the distance, and yet when we walk to the spot where they apparently merged we find them to be parallel. The wheels of automobiles seen on television seem to be going backward when the automobile is seen to be moving forward. Yet this is impossible. Such examples of distorted perception could be multiplied endlessly. Each of these sense phenomena is thus misleading in some way. If human beings were to accept the world as being exactly how it looks, \_\_\_\_\_. They would think the stick in water really to be bent, the writing on pages really to be reversed, and the wheels really to be going backward.

\* immerse: 담그다 \*\* penetrable: 뚫고 들어갈 수 있는 \*\*\* converge: 수렴하다

- ① they would be deceived as to how things really are
- ② their senses would be seen as a gateway to imaginative worlds
- ③ understanding the physical world would become effortless and simple
- ④ they would realize the world is without illusions and full of objective truths
- ⑤ their distorted perceptions would quickly fade away

**Sentence Structure**

- A straight stick put in water looks bent; yet we do not believe [it has become bent just because it was immersed in water, { which is an easily penetrable liquid }].

[ ]는 believe의 목적어 역할을 하는 명사절로, 그 안의 대명사 it은 a straight stick을 가리키며, { }는 앞에 나온 water를 부가적으로 설명하는 관계절이다.

**Word Search**

주어진 문장에 들어갈 적절한 영어 단어를 본문에서 찾아 쓰시오. (필요시 형태를 바꿀 것)

1. The roads run p\_\_\_\_\_ to each other for several miles, always maintaining the same distance apart.
2. The d\_\_\_\_\_ reflections in the funhouse mirrors amused the children.
3. Her p\_\_\_\_\_ of the situation was influenced by misinformation.

## Exercise 6 함축 의미 추론

25007-0030

밑줄 친 the welcoming shelter of shade trees planted by others가 다음 글에서 의미하는 바로 가장 적절한 것은?

According to an ancient Greek proverb, “A society grows great when old men plant trees in whose shade they shall never sit.” Likewise, an academic culture grows great when senior scholars perform acts of generosity for junior academics who may never know their names. Literary scholar and poet Lesley Wheeler remains “endlessly grateful” to the two anonymous readers whose thoughtful responses to her first book manuscript set her on the path to becoming a successful scholar: “They told me bluntly what was wrong with the book, but they also found the time to praise it; and that was enough encouragement.” Having benefited from the welcoming shelter of shade trees planted by others, Wheeler has little patience for “cranky” referees who poison the air with mean-spirited reviews. She takes care to ensure that her own feedback to colleagues and students is always gracious and constructive: “The conscientiousness and generosity that I’ve seen directed at my work is something that I want to pay back.”

\* anonymous: 익명의 \*\* bluntly: 직설적으로 \*\*\* cranky: (성미가) 까다로운, 심기가 뒤뜰린

- ① the implicit drawbacks and influence of an academic environment
- ② the support and guidance from senior scholars to junior academics
- ③ the satisfaction and fulfillment derived from academic achievement
- ④ the acknowledgment and validation of one’s academic contributions
- ⑤ the advantage gained by outperforming others in academia through publishing

### Sentence Structure

- Likewise, an academic culture grows great [when senior scholars perform acts of generosity for junior academics {who may never know their names}].

[ ]는 시간의 부사절이고, 그 안의 { }는 junior academics를 수식하는 관계절이다.

**Word Search** 주어진 문장에 들어갈 적절한 영어 단어를 본문에서 찾아 쓰시오. (필요시 형태를 바꿀 것)

1. His g \_\_\_\_\_ was evident when he donated a large sum to help rebuild the hospital.
2. The letter was a \_\_\_\_\_, so we couldn’t figure out who sent it.
3. Her c \_\_\_\_\_ feedback helped improve the project and make it more effective.

## Exercise 7 빈칸 추론

다음 빈칸에 들어갈 말로 가장 적절한 것은?

25007-0031

Working in small groups may foster the creativity of students, but just putting students together to work in small groups does not mean that creativity will automatically flourish. As with other aspects of productive teamwork, this process requires learning. According to Meissner, a notable researcher in educational psychology, to further creative thinking in mathematics education, we need to further \_\_\_\_\_. Students need to learn how to avoid the negative factors that affect creativity: *cognitive interference*, which includes production blocking, task-irrelevant behavior, and cognitive overload; and *social inhibition*, which includes social anxiety, free riding, and illusion of productivity. They also need to learn to recognize factors that can strengthen the potential of groups to generate ideas; for example, *social stimulation*, which includes both increased individual accountability and the development of shared standards for team performance; and *cognitive stimulation*, which includes stimulation of associations, attention to others' contributions, and opportunities to incubate ideas.

\* incubate: 생각해 내다

- ① various educational technologies
- ② both individual and social abilities
- ③ a supportive and inclusive classroom culture
- ④ tailored instructions, especially in after-school activities
- ⑤ collaborative projects and structured teamwork exercises

### Sentence Structure

- Working in small groups may foster the creativity of students, but [just putting students together to work in small groups] does not mean [that creativity will automatically flourish].  
 첫 번째 [ ]는 동명사구로 문장의 주어 역할을 하며, 두 번째 [ ]는 mean의 목적어 역할을 하는 명사절이다.

### Word Search

주어진 문장에 들어갈 적절한 영어 단어를 본문에서 찾아 쓰시오. (필요시 형태를 바꿀 것)

1. The news report cast a **n** \_\_\_\_\_ light on the company's environmental practices, producing more protests from environmentalists.
2. Factory **p** \_\_\_\_\_ has increased due to improved automation.
3. She showed great **p** \_\_\_\_\_ as a young athlete.

## Exercise 8 빈칸 추론

다음 빈칸에 들어갈 말로 가장 적절한 것은?

25007-0032

Although it has been demonstrated that spaced learning sessions are usually more effective than massed learning sessions, in real-life settings this advantage may sometimes be \_\_\_\_\_. For example, there are some occasions when we only have a limited period of time available for study (for example, when we have only one hour left to revise before an exam); in such cases, it may be better to use the entire period rather than to take breaks, which will waste some of our available time. Again, a very busy person might have difficulty fitting a large number of separate learning sessions into their daily schedule. A further problem is that spaced learning obviously requires more time overall (i.e., total time including rest breaks) than massed learning, and therefore may not represent the most efficient use of that time unless the rest breaks can be used for something worthwhile. Because spaced learning can create practical problems of this kind, there is no clear agreement about its value in a real-life learning setting such as a school classroom.

\* spaced learning: 분산 학습 \*\* massed learning: 집중 학습

- ① challenged by time constraints
- ② limited when preparation is rushed
- ③ compromised by practical considerations
- ④ weakened by inconsistent learning methods
- ⑤ ignored due to the perceived low value of breaks

### Sentence Structure

- A further problem is [that spaced learning {obviously requires more time overall (i.e., total time including rest breaks) than massed learning}, and therefore {may not represent the most efficient use of that time unless the rest breaks can be used for something worthwhile}].

[ ]는 문장의 주격 보어 역할을 하는 명사절이며, 그 안에서 두 개의 { }가 and로 연결되어 명사절의 주어 spaced learning에 대등하게 이어져 있다.

**Word Search** 주어진 문장에 들어갈 적절한 영어 단어를 본문에서 찾아 쓰시오. (필요시 형태를 바꿀 것)

1. The library is **a** \_\_\_\_\_ for students to use from 8 AM to 8 PM every day.
2. Attending the conference was a **w** \_\_\_\_\_ experience because of the valuable insights gained.
3. The course includes both theoretical knowledge and **p** \_\_\_\_\_ training.

**Exercise 9** 빈칸 추론

다음 빈칸에 들어갈 말로 가장 적절한 것은?

25007-0033

In recent years, more H<sub>2</sub>O has been flowing from low-value crops (cotton and alfalfa) to high-value ones (nuts and berries). Ailing farms are selling their water rights to productive industry and rapidly growing cities. Food grown in wet, green climates (the northeastern United States, Brazil) is increasingly being exported to dry, brown ones (Arizona, India), allowing their water to be conserved for drinking supplies, for maintaining aquifer levels, or for other high-priority uses. Yet people have tended to dance around the question of pricing water in a way that reflects scarcity. Because water is an essential resource, it has no “market value,” as, say, oil does. But with no price incentive to use it efficiently, people often waste water by using vast quantities for energy and mineral projects, and polluting it. In many places water is free, or priced so low that the revenue it generates is not enough to maintain, or upgrade, reservoirs, distribution pipes, and treatment plants. While citizens have good reason to be cautious of water privatizers, \_\_\_\_\_.

\* alfalfa: 알팔파, 자주개자리(사료 작물인 콩과(科) 식물) \*\* ailing: 침체된, 병든 \*\*\* aquifer: 대수층(지하수를 품고 있는 지층)

- ① cheap water invites waste
- ② the rush to price water could slow down
- ③ public control keeps water flowing for all
- ④ climate change will restore water resources
- ⑤ water conservation is less essential for urban residents

**Sentence Structure**

- Food grown in wet, green climates (the northeastern United States, Brazil) is increasingly **being exported** to dry, brown ones (Arizona, India), [allowing their water to be conserved for drinking supplies, for maintaining aquifer levels, or for other high-priority uses].

문장의 주어부 Food grown in wet, green climates가 export라는 동작을 하는 주체가 아니라 대상이므로 진행형 수동태 is being exported가 사용되었으며, [ ]는 주절이 기술하는 내용의 부수적 상황을 나타내는 분사구문이다.

**Word Search** 주어진 문장에 들어갈 적절한 영어 단어를 본문에서 찾아 쓰시오. (필요시 형태를 바꿀 것)

1. The economic policies should r \_\_\_\_\_ the needs and priorities of all citizens.
2. Good communication skills are e \_\_\_\_\_ for effective teamwork.
3. The company's total r \_\_\_\_\_ increased significantly after launching the new product line.

## Exercise 10 빈칸 추론

다음 빈칸에 들어갈 말로 가장 적절한 것은?

25007-0034

At their most basic level, monsters represent fears held by society, fears associated with dangers perceived in the surrounding world. These fears have a powerful evolutionary history by encouraging people to flee instead of fighting suicidal battles. When ancient hunters encountered a saber-toothed tiger by accident, they ran. When the human ancestor *Homo erectus* caught angry cave bears by surprise, it ran. When chimpanzees and bonobos, the nearest genetic relatives to modern humans, encounter large predators in the wild, they run. While Hollywood heroes have made running away distinctly unpopular on the silver screen, every single actor who has ever portrayed a hero who stood his or her ground against some abominable terror comes from a long genetic lineage of cowards who fled in the face of danger. That is why they are here to act today. If their ancestors had fought against monsters far more powerful than themselves, as Hollywood heroes do all the time, their lineage would have been destroyed by predators long ago. Fear, in short,

\* saber-toothed tiger: 검치호랑이 \*\* abominable: 끔찍한 \*\*\* lineage: 혈통

- ① keeps people alive
- ② inspires heroic acts
- ③ drives people to fight
- ④ creates a sense of power
- ⑤ makes individuals stronger

### Sentence Structure

- [While Hollywood heroes have made running away distinctly unpopular on the silver screen], every single actor [who has ever portrayed a hero {who stood his or her ground against some abominable terror}] comes from a long genetic lineage of cowards [who fled in the face of danger].

첫 번째 [ ]는 접속사 While이 이끄는 양보의 의미를 나타내는 부사절이다. 두 번째 [ ]는 every single actor를 수식하는 관계절이고, 그 안의 { }는 a hero를 수식하는 관계절이다. 세 번째 [ ]는 cowards를 수식하는 관계절이다.

**Word Search** 주어진 문장에 들어갈 적절한 영어 단어를 본문에서 찾아 쓰시오. (필요시 형태를 바꿀 것)

1. A \_\_\_\_\_ myths and legends often explain natural phenomena in imaginative ways.
2. When hiking in the forest, it's not uncommon to e \_\_\_\_\_ various wildlife unexpectedly.
3. The cheetah is a skilled p \_\_\_\_\_ known for its incredible speed when hunting prey.

**Exercise 11** 빈칸 추론

다음 빈칸에 들어갈 말로 가장 적절한 것은?

25007-0035

In the 1950s, hardly anyone was interested in yeast. To most, it didn't seem we could learn much about our complex selves by studying a tiny fungus. It was a struggle to convince the scientific community that yeast could be useful for something more than baking bread, brewing beer, and vinting wine. What Mortimer and Johnston recognized, and what many others began to realize in the years to come, was that \_\_\_\_\_ . For their size, their genetic and biochemical makeup is extraordinarily complex, making them an exceptionally good model for understanding the biological processes that sustain life and control lifespans in large complex organisms such as ourselves. If you are doubtful that a yeast cell can tell us anything about cancer, Alzheimer's disease, rare diseases, or aging, consider that there have been five Nobel Prizes in Physiology or Medicine awarded for genetic studies in yeast, including the 2009 prize for discovering how cells counteract telomere shortening, one of the characteristics of aging.

\* fungus: 균류 \*\* vint: (과실주를) 빤다, 만들다 \*\*\* telomere: 텔로미어, 말단 소립

- ① new discoveries often rediscover what has long existed
- ② those tiny yeast cells are not so different from ourselves
- ③ science must combine fields to grasp complex phenomena
- ④ we can improve the quality of our foods by including yeast
- ⑤ understanding cells is critical for discovering new treatments

**Sentence Structure**

- **It** was a struggle [to convince the scientific community {that yeast could be useful for something more than baking bread, brewing beer, and vinting wine}].

It은 형식상의 주어이고, [ ]는 내용상의 주어이며, 그 안의 { }는 convince의 직접목적어 역할을 하는 명사절이다.

**Word Search**

주어진 문장에 들어갈 적절한 영어 단어를 본문에서 찾아 쓰시오. (필요시 형태를 바꿀 것)

1. The ecosystem in the rainforest is highly **c** \_\_\_\_\_, with numerous species interacting in delicate balance.
2. Using **g** \_\_\_\_\_ engineering, scientists hope to increase crop resilience to diseases and pests.
3. The museum has a **r** \_\_\_\_\_ collection of artifacts from ancient civilizations.

## Exercise 12 함축 의미 추론

25007-0036

밑줄 친 to arrive safely at your destination with money in your pocket이 다음 글에서 의미하는 바로 가장 적절한 것은?

Rules govern our daily lives. Some of these rules are explicit, imposed by government: “obey the speed limit,” “no parking,” “April 15 is tax day.” But most are informal, often unspoken cultural norms — rules of politeness, rules of conduct in the business world, rules of interaction between people. Most are commonly understood traditions that have built up over time, habits so ordinary that we usually don’t even think about them. Unfortunately, not all such involuntary habits and subconscious conventions are positive or productive. American business and political communication is rife with bad habits and unhelpful tendencies that can do serious damage to the companies and causes they seek to promote. Just as in every other field, there are rules to good, effective communication. They may not be as inflexible and absolute as the rules against speeding or avoiding your taxes, but they’re just as important if you wish to arrive safely at your destination with money in your pocket.

\* rife with: ~이 만연한, ~로 가득 찬

- ① to keep up with the rapidly changing trends of the industry
- ② to foster long-term relationships with community members
- ③ to capitalize on international opportunities without regard to risk
- ④ to maintain a minimum amount of taxes within the regulatory range
- ⑤ to effectively communicate to avoid suffering negative consequences

### Sentence Structure

- Most are [commonly understood traditions {that have built up over time}], [habits {so ordinary that we usually don’t even think about them}].

두 번째 [ ]는 첫 번째 [ ]의 내용을 구체적으로 재진술하는 동격어구이다. 첫 번째 [ ] 안의 { }는 commonly understood traditions를 수식하는 관계절이고, 두 번째 [ ] 안의 { }는 habits를 수식하며, 「so ~ that ...」 구문은 ‘...할 만큼 ~한’이라는 의미이다.

**Word Search** 주어진 문장에 들어갈 적절한 영어 단어를 본문에서 찾아 쓰시오. (필요시 형태를 바꿀 것)

1. ○ \_\_\_\_\_ people can make a big difference through small acts of kindness.
2. Blinking is an i \_\_\_\_\_ reaction that protects our vision.
3. There is a t \_\_\_\_\_ for people to resist change.

**Exercise 1** 빈칸 추론

다음 빈칸에 들어갈 말로 가장 적절한 것은?

25007-0037

Let's start with the statement "Humans are causing climate change by burning fossil fuels." It is the basis upon which people all over the world, including me, are calling for the rapid end to fossil fuel use and the transition to carbon-emission-free energy sources. It's a pretty bold statement, and it is very different from saying *that* the climate is changing — what scientists call "detection." If we're going to argue for a massive change in human society, which is what will be required to end our use of fossil fuels, it seems reasonable to ask that we move beyond detection. After all, fossil fuels, despite their problems, have provided tremendous benefits to society over the twentieth century. If we (the climate-concerned public) are going to insist that we stop using fossil fuels, it is incumbent upon us to prove that the downside is greater than the very real upside that fossil fuels have offered. We need to prove, beyond a reasonable doubt, that climate is changing *and* that human use of fossil fuels, not something else, is responsible for the climate change we are observing.

\* incumbent upon: ~의[에게] 의무인

- ① We need attribution in addition to detection
- ② It all starts and ends with saying that climate is changing
- ③ We must disengage from subjectivity to fight climate change
- ④ Detecting existing problems can lead to cooperative solutions
- ⑤ Every single change should be detected with scientific precision

**Sentence Structure**

- It is the basis [upon which people all over the world, including me, are calling for {the rapid end to fossil fuel use} and {the transition to carbon-emission-free energy sources}].

[ ]는 the basis를 수식하는 관계절이고, 두 개의 { }가 and로 대등하게 연결되어 calling for의 목적어 역할을 하고 있다.

**Word Search** 주어진 문장에 들어갈 적절한 영어 단어를 본문에서 찾아 쓰시오. (필요시 형태를 바꿀 것)

- 1. The patient made a **r**\_\_\_\_\_ recovery.
- 2. The country underwent a peaceful **t**\_\_\_\_\_ from dictatorship to democracy.
- 3. The team made the **b**\_\_\_\_\_ move of trading its star player.

## Exercise 2 빈칸 추론

다음 빈칸에 들어갈 말로 가장 적절한 것은?

25007-0038

The grammatical structure of a language is a ‘social fact’ in Durkheim’s sense of being external to and constraining for individual speakers. It is independent of their subjective preferences and they must follow the rules if they are to be understood. However, the grammatical rules of gender, agreement, number, subject and object, possessive, and so on are not, in general, consciously followed and applied by the individuals who speak to each other. Speakers typically have only a very limited and partial awareness of the rules of their own grammar, and speaking grammatically is a matter of unreflective habit rather than conscious rule following. The grammatical rules of a language, then, \_\_\_\_\_ . They may be formulated in a book of grammar, but such a book *records* the grammar — more or less imperfectly — and does not *comprise* the grammar. The rules that are followed in forming a ‘correct’ utterance and a well-organised discourse exist only in the minds of the individual speakers as learned dispositions held in the neurophysiological memory traces of their brains.

\* neurophysiological: 신경생리학적

- ① shape each speaker’s understanding of the other person
- ② serve as the key framework for effective communication
- ③ do not exist apart from the minds of the individual speakers
- ④ influence the way in which subjective feelings are expressed
- ⑤ exert a tremendous constraint on recalling past conversations

### Sentence Structure

- However, [the grammatical rules of gender, agreement, number, subject and object, possessive, and so on] **are** not, in general, consciously followed and applied by the individuals [who speak to each other].  
 첫 번째 [ ]는 문장의 주어 역할을 하고, 주어의 핵심어구가 the grammatical rules로 복수여서 복수형 동사 are가 이어졌다. 두 번째 [ ]는 the individuals를 수식하는 관계절이다.

**Word Search** 주어진 문장에 들어갈 적절한 영어 단어를 본문에서 찾아 쓰시오. (필요시 형태를 바꿀 것)

1. This lotion is for **e** \_\_\_\_\_ use only.
2. The capacity of those roads will **c** \_\_\_\_\_ the amount of car travel.
3. There was a complete lack of **a** \_\_\_\_\_ of the issues involved.

**Exercise 3** 빈칸 추론

다음 빈칸에 들어갈 말로 가장 적절한 것은?

25007-0039

When environment involves human interests, it must necessarily be understood in relation to humans and not as an assemblage of independent objects. We can find support for this in the work of social psychologists such as Kurt Lewin and J. J. Gibson. Lewin envisioned a social world comprised of vectors of force between participants and the things and conditions with which they interact. These vectors invite particular behaviors, and this led Lewin to call them by the German term *Affordungsqualitäten*, translated into English as “invitational qualities.” More recently, the perceptual psychologist J. J. Gibson studied the ways in which the design and appearance of environmental configurations and objects encourage particular responses in human behavior. He called these connections “affordances” for behavior, clearly influenced by Lewin’s terminology and resembling his observations. The work of Lewin and Gibson is important and instructive, for it suggests that environment is not just open space filled with arrangements of independent objects but rather is a field of forces in compelling relationships of attraction, repulsion, and neutrality or indifference. Environment is, then, \_\_\_\_\_.

\* configuration: 구성, 배치 \*\* affordance: (행동) 유도성 \*\*\* repulsion: 반발, 혐오감

- ① a field that includes the human participant
- ② a reason behind the conflicts within society
- ③ an area that suppresses our emotions through objects
- ④ a trigger for negative emotional reactions in individuals
- ⑤ an invisible force that disconnects humans from objects

**Sentence Structure**

- Lewin envisioned a social world [comprised of vectors of force between participants and the things and conditions {with which they interact}].

[ ]는 a social world를 수식하는 분사구이고, { }는 the things and conditions를 수식하는 관계절이다.

**Word Search**

주어진 문장에 들어갈 적절한 영어 단어를 본문에서 찾아 쓰시오. (필요시 형태를 바꿀 것)

1. Humans are not just an **a** \_\_\_\_\_ of chemicals or a mindless machine.
2. It was very **i** \_\_\_\_\_ to watch the doctors work.
3. He was a sad man with a **c** \_\_\_\_\_ need to talk about his unhappiness.

## Exercise 4 빈칸 추론

다음 빈칸에 들어갈 말로 가장 적절한 것은?

25007-0040

As many journalism scholars have argued, print-era journalists rejected audience research because doing so was one of the only means to protect their always-unstable professional status. Sociologist Andrew Abbott has characterized professions as “somewhat exclusive groups of individuals applying somewhat abstract knowledge to particular cases.” Although it is commonly categorized as a profession, journalism has long struggled to comfortably inhabit this definition. Even before the rise of the internet helped shift institutional gatekeeping power away from news organizations and toward technology platforms, journalists had difficulty establishing themselves as a “somewhat exclusive group of individuals.” Indeed, while traditional professions such as medicine and law rely on strict licensing requirements to limit entry into the profession, the First Amendment prohibits U.S. journalism from establishing any such thing. Nor can journalists lay a strong claim to jurisdiction over a form of abstract knowledge. As journalism scholar Matt Carlson has argued, “abstraction makes for bad journalism. Clarity, especially in the explanation of complex topics, makes for good journalism.” The accessibility of journalistic language is helpful for informing the public, but it also renders \_\_\_\_\_ potentially suspect.

\* First Amendment: (미국 헌법) 수정 제1조(언론·종교·집회의 자유를 정한 조항)

\*\* jurisdiction: 관할(권) \*\*\* render: ~을 (어떤 상태가 되게) 만들다

- ① journalists' claims to specialized expertise
- ② diverse opinions of journalists on social issues
- ③ journalism as a medium of conveying the truth
- ④ moral duties that journalists assert they perform
- ⑤ journalists' intention of accepting audience research

### Sentence Structure

- As many journalism scholars have argued, print-era journalists rejected audience research because **doing so** was one of the only means [to protect their always-unstable professional status].  
doing so는 rejecting audience research를 대신하고, [ ]는 the only means를 수식하는 to부정사구이다.

**Word Search** 주어진 문장에 들어갈 적절한 영어 단어를 본문에서 찾아 쓰시오. (필요시 형태를 바꿀 것)

1. Doctors have traditionally enjoyed high social **s** \_\_\_\_\_.
2. Most **p** \_\_\_\_\_ in the medical field require years of training.
3. The room is for the **e** \_\_\_\_\_ use of guests.

**Exercise 5** 빈칸 추론

다음 빈칸에 들어갈 말로 가장 적절한 것은?

25007-0041

Management, especially of anything as complex as a transportation system, is very difficult. There are often many different organizations involved, each of which has multiple divisions, with multiple levels of authority, and often many lengthy, written procedure manuals. To make matters worse, the manuals are seldom kept up to date and, in any event, cannot possibly consider every combination of factors that might occur. During the incident, the people responsible for maintaining control (the pilots, in most commercial aviation incidents) waste valuable time studying the different manuals, trying to find the relevant case. Modern computer systems attempt to help by automatically diagnosing the situation and either responding autonomously or offering operators the instructions to be followed, but the diagnosis or recommended course of actions is not always appropriate (because in each complex system, most accidents involve different unique factors). Different organizations might be involved: police and firefighters, company safety representatives, multiple teams from different divisions of a company, and different companies or government and regulatory agencies who must coordinate their decisions and actions. It is rare that \_\_\_\_\_.

\* aviation: 항공 \*\* autonomously: 독자적으로

- ① the result is smooth, flawless management
- ② a vision is universally shared within a system
- ③ managers look into the past to predict future risks
- ④ technology causes conflicting management problems
- ⑤ people use unbiased reasoning in their decision-making

**Sentence Structure**

- There are often many different organizations involved, [each of which has { multiple divisions, with multiple levels of authority }, and { often many lengthy, written procedure manuals }].  
 [ ]는 many different organizations involved에 대해 부가적으로 설명하는 관계절이고, 그 안의 두 개의 { }는 has의 목적어 역할을 하며 and로 대등하게 연결되어 있다.

**Word Search** 주어진 문장에 들어갈 적절한 영어 단어를 본문에서 찾아 쓰시오. (필요시 형태를 바꿀 것)

1. The report blames bad **m**\_\_\_\_\_.
2. Campuses are usually accessible by public **t**\_\_\_\_\_.
3. I work in the administration **d**\_\_\_\_\_ as an office manager.

## Exercise 6 함축 의미 추론

밑줄 친 Life has a way of clipping our wings.가 다음 글에서 의미하는 바로 가장 적절한 것은?

25007-0042

Age is not the only determinant of spatial skills. While thirteen-year-old children have all the cognitive attributes they need to be proficient at wayfinding, some are better at it than others. By this point, parental attitudes, freedom of movement, cognitive differences and life experience have already begun to leave their imprint, and they never ease off. All of us may be explorers when we're born, but few of us stay that way. We end up suppressing our childish natures, slipping into routines and following the routes we always take. A recent study by Canadian psychologists found that 84 per cent of eight-year-olds navigate by scrutinizing their surroundings and building a mental map, a so-called 'spatial' strategy that is also used by almost all competent adult navigators. The alternative is a more closed, 'egocentric' strategy, which entails learning and following a sequence of turns. Only 46 per cent of us still use the spatial approach in our twenties, and 39 per cent in our sixties. It seems that we all start off wandering free, but most of us end up on the straight and narrow. Life has a way of clipping our wings.

\* imprint: 각인 \*\* scrutinize: 세심히 살피다 \*\*\* entail: 수반하다

- ① Life forces us to explore our inner world, not the external one.
- ② As we age, our spatial perception becomes distorted by cognitive bias.
- ③ The biggest obstacle for children to navigate is their own fear of failure.
- ④ Our tendencies to follow determined paths are suppressed by social pressure.
- ⑤ Over time, we lose our sense of adventure, restrained from navigating boldly.

### Sentence Structure

- [**While** thirteen-year-old children have all the cognitive attributes {they need <to be proficient at wayfinding>}], some are better at **it** than others.

[ ]는 '~이기는 하지만'이라는 뜻의 **While**이 이끄는 부사절이며, { }는 관계사가 생략된 관계절로 all the cognitive attributes 를 수식한다. < >는 목적을 나타내는 to부정사구이다. it은 wayfinding을 가리킨다.

**Word Search** 주어진 문장에 들어갈 적절한 영어 단어를 본문에서 찾아 쓰시오. (필요시 형태를 바꿀 것)

1. Soil and climate are the main **d** \_\_\_\_\_ of how land is used.
2. This task is designed to test children's **s** \_\_\_\_\_ awareness.
3. He possesses the essential **a** \_\_\_\_\_ of a journalist.

**Exercise 7** 빈칸 추론

다음 빈칸에 들어갈 말로 가장 적절한 것은?

25007-0043

The bird songs we hear every day are more than beautiful. They serve a practical purpose. Birds employ their voices to call their mates, find their flock, claim territory, scare off intruders, warn others about predators, and for countless other functions. For instance, Japanese and Swiss researchers recently discovered that Japanese great tits, small birds with jet-black heads and necks with prominent white cheeks, use syntax in their songs, just as humans do in their speech. Syntax is crucial to language. For example, if you say, “I love that restaurant,” the message is clear. But not even Star Wars’ Master Yoda could understand, “Restaurant love that I.” Until recently, scientists believed that only humans could string together such vocalizations. The Japanese great tit, it turns out, is the first animal apart from humans who can use phonological syntax — the ability to combine sounds that individually have no meaning into a collective sound — that does. To instruct other members of his flock to scan for predators, or to attract a mate, a great tit must \_\_\_\_\_ — if the notes are sung differently, the study found, other birds will not react.

\* great tit: 박새 \*\* syntax: 구문 \*\*\* phonological: 음운론적인

- ① produce notes in unexpected patterns
- ② vary the volume of his song dynamically
- ③ sing several distinct notes in the correct order
- ④ deliver each song with its own unique rhythm
- ⑤ copy the exact sounds of different bird species

**Sentence Structure**

- For instance, Japanese and Swiss researchers recently discovered [that Japanese great tits, {small birds with jet-black heads and necks with prominent white cheeks}], use syntax in their songs, just as humans do in their speech].

[ ]는 discovered의 목적어 역할을 하는 명사절이고, { }는 Japanese great tits와 동격 관계를 이룬다.

**Word Search**

주어진 문장에 들어갈 적절한 영어 단어를 본문에서 찾아 쓰시오. (필요시 형태를 바꿀 것)

1. The smell of freshly baked bread from the bakery was enough to **a** \_\_\_\_\_ passersby.
2. Artists often **c** \_\_\_\_\_ different materials to create unique and innovative works.
3. The **p** \_\_\_\_\_ features of the mountain range were clearly visible from miles away.

## Exercise 8 빈칸 추론

다음 빈칸에 들어갈 말로 가장 적절한 것은?

25007-0044

When an organism is confronted with some sort of threat, it typically becomes vigilant, searches to gain information about the nature of the threat, struggles to find an effective coping response. And once a signal indicates safety — the lion has been evaded, the traffic cop buys the explanation and doesn't issue a ticket — the organism can relax. But this is not what occurs in an anxious individual. Instead, there is a nervous scrambling among coping responses — abruptly shifting from one to another without checking whether anything has worked, an agitated attempt to cover all the bases and attempt a variety of responses simultaneously. Or there is an inability to detect when the safety signal occurs, and the restless vigilance keeps going. By definition, anxiety makes little sense outside the context of what the environment is doing to an individual. In that framework, the brain chemicals and, ultimately, the genes relevant to anxiety don't make you anxious. They make you more responsive to anxiety-provoking situations, make it harder to \_\_\_\_\_.

\* vigilant: 경계하는 \*\* abruptly: 갑자기 \*\*\* agitated: 동요된

- ① respect others' personal boundaries
- ② maintain focus on established goals
- ③ come up with a possible escape plan
- ④ detect safety signals in the environment
- ⑤ look at the situation from the bright side

### Sentence Structure

- By definition, anxiety makes little sense outside the context of [what the environment is doing to an individual].

[ ]는 of의 목적어 역할을 하는 명사절로 「what + 주어 + 동사」의 구조가 쓰이고 있다.

**Word Search** 주어진 문장에 들어갈 적절한 영어 단어를 본문에서 찾아 쓰시오. (필요시 형태를 바꿀 것)

1. The thief managed to e \_\_\_\_\_ the police by hiding in an abandoned building.
2. He had to s \_\_\_\_\_ his career from sports to academics after his injury.
3. The fire alarm can d \_\_\_\_\_ sudden increases in heat and smoke.

**Exercise 9** 빈칸 추론

다음 빈칸에 들어갈 말로 가장 적절한 것은?

25007-0045

Babies use statistical learning to make predictions about the world, guiding their actions. Like little statisticians, they form hypotheses, assess probabilities based on their knowledge, integrate new evidence from the environment, and perform tests. In one creative study by the developmental psychologist Fei Xu, ten- to fourteen-month-old children first expressed a preference for pink or black lollipops, then were shown two candy jars: one containing more black lollipops than pink, and one with more pink than black. The experimenter then closed her eyes and drew one lollipop from each jar so infants could see only the stick, not the color. Each lollipop was placed into a separate, opaque cup with only the stick showing. Infants crawled to the cup that was statistically more likely to contain their preferred color, because it came from a jar where that color was in the majority. Experiments like this demonstrate that infants are not merely reactive to the world. Even from a very young age, they actively \_\_\_\_\_, to maximize the outcomes they desire.

\* lollipop: 막대 사탕 \*\* opaque: 불투명한

- ① absorb information selectively from their surroundings
- ② use observed exceptions to understand creative processes
- ③ improve their decision-making process utilizing input from adults
- ④ predict potential outcomes relying on their current emotional state
- ⑤ estimate probabilities based on patterns that they observe and learn

**Sentence Structure**

- Infants crawled to the cup [that was statistically more likely to contain their preferred color], because it came from a jar [where that color was in the majority].

첫 번째 [ ]는 the cup을, 두 번째 [ ]는 a jar를 각각 수식하는 관계절이다.

**Word Search** 주어진 문장에 들어갈 적절한 영어 단어를 본문에서 찾아 쓰시오. (필요시 형태를 바꿀 것)

1. His **p** \_\_\_\_\_ about the election results turned out to be accurate.
2. The lawyer presented **e** \_\_\_\_\_ to prove his client's innocence.
3. The first aid kit should **c** \_\_\_\_\_ bandages, pain relievers, and gauze.

## Exercise 10 빈칸 추론

다음 빈칸에 들어갈 말로 가장 적절한 것은?

25007-0046

David Howes, a professor of anthropology, notes the frequent association in different cultures between scents and rituals of transition, such as funerals or rites of passage. He suggests that scent is felt to be symbolically appropriate for moments of social transition because it so frequently accompanies and marks other types of physical transition, as when cooking smells signal the transformation of raw ingredients into food. While scents tend to escape spaces and spread out of human control, our experience of them is frequently liminal, as we notice scents far more strongly when first entering their range. You smell baking bread strongly as you enter a house, but after a few minutes inside, you may no longer be able to smell it even with deliberate effort, a physical process known as olfactory adaptation or exhaustion. It takes an overwhelming smell to retain our notice after a period of constant exposure. Smells signal \_\_\_\_\_, and are thus used to mark socially important moments of change.

\* rite of passage: 통과 의례 \*\* liminal: 전환적인, 경계에 있는 \*\*\* olfactory: 후각의

- ① adaptation in sensory perception over time
- ② transitions through space as well as changes of state
- ③ adjustments of setting to create the mood for an event
- ④ the social status assigned to each individual by society
- ⑤ the invisible architecture of social spaces and collective memory

### Sentence Structure

- [While scents tend to {escape spaces} and {spread out of human control}] our experience of them is frequently liminal, [as we notice scents far more strongly when first entering their range].

첫 번째 [ ]는 양보의 의미를 가진 부사절이고, 두 개의 { }가 and로 대등하게 연결되어 to에 이어진다. 두 번째 [ ]는 이유를 나타내는 부사절이다.

**Word Search** 주어진 문장에 들어갈 적절한 영어 단어를 본문에서 찾아 쓰시오. (필요시 형태를 바꿀 것)

1. The s \_\_\_\_\_ of fresh flowers filled the room, creating a pleasant atmosphere.
2. She made a d \_\_\_\_\_ effort to stay calm during the stressful situation.
3. The walls are thick enough to r \_\_\_\_\_ heat during the winter.

**Exercise 11** 빈칸 추론

다음 빈칸에 들어갈 말로 가장 적절한 것은?

25007-0047

Variability in judgments is expected and welcome in a competitive situation in which the best judgments will be rewarded. When several companies (or several teams in the same organization) compete to generate innovative solutions to the same customer problem, we don't want them to focus on the same approach. The same is true when multiple teams of researchers attack a scientific problem, such as the development of a vaccine: we very much want them to look at it from different angles. Even forecasters sometimes behave like competitive players. The analyst who correctly calls a recession that no one else has anticipated is sure to gain fame, whereas the one who never strays from the agreement remains unnoticed. In such settings, variability in ideas and judgments is again welcome, because variation is only the first step. In a second phase, the results of these judgments will be pitted against one another, and the best will triumph. In a market as in nature, selection \_\_\_\_\_.

\* recession: 불경기 \*\* stray from: ~에서 벗어나다 \*\*\* pit against: ~과 맞붙이다

- ① reflects general trends
- ② can lead to cooperation
- ③ should not allow flexibility
- ④ cannot work without variation
- ⑤ requires a step-by-step process

**Sentence Structure**

- [The analyst {who correctly calls a recession <that no one else has anticipated>}] is sure to gain fame, whereas the one [who never strays from the agreement] remains unnoticed.  
 첫 번째 [ ]는 문장의 주어이고, { }는 The analyst를 수식하는 관계절이며, < >는 a recession을 수식하는 관계절이다. 두 번째 [ ]는 the one을 수식하는 관계절이다.

**Word Search** 주어진 문장에 들어갈 적절한 영어 단어를 본문에서 찾아 쓰시오. (필요시 형태를 바꿀 것)

1. His j\_\_\_\_\_ was clouded by his emotions, leading to an unfair decision.
2. The engineer proposed an innovative s\_\_\_\_\_ to improve the machine's efficiency.
3. The app is designed to g\_\_\_\_\_ random numbers for the game.

## Exercise 12 함축 의미 추론

밑줄 친 Do your homework가 다음 글에서 의미하는 바로 가장 적절한 것은?

25007-0048

Intelligent failures begin with preparation. No scientist wants to waste time or materials on experiments that have been run before and failed. Do your homework. The classic intelligent failure is hypothesis driven. You've taken the time to think through what might happen — why you have reason to believe that you could be right about what will happen. My Harvard colleague Thomas Eisenmann, an entrepreneurship expert, finds that many start-up failures are caused by the skipping of basic homework. For example, Triangulate, an online dating start-up, rushed to launch fully functional offerings that didn't fit any market needs. Eager to launch fast, founders skipped the research — customer interviews to probe for unmet needs. Paying no attention to that crucial preparation, the company paid the price. Thomas attributes this common failure, in part, to “the ‘fail fast’ mantra,” which overemphasizes action, shortchanging preparation. Moreover, while this might seem self-evident, once you've done the homework, you must pay attention to what it's telling you.

\* entrepreneurship: 기업가 정신 \*\* mantra: (특히 기도나 명상을 할 때 외는) 주문

- ① Move quickly to get a competitive edge.
- ② Ask for advice when you encounter an obstacle.
- ③ Reflect on your mistakes to gain valuable lessons.
- ④ Regularly monitor progress and make adjustments.
- ⑤ Take time to conduct thorough research before actual work.

### Sentence Structure

- [Paying no attention to that crucial preparation], the company paid the price.  
[ ]는 이유를 나타내는 분사구문으로, As the company paid no attention to that crucial preparation과 비슷한 의미이다.

**Word Search** 주어진 문장에 들어갈 적절한 영어 단어를 본문에서 찾아 쓰시오. (필요시 형태를 바꿀 것)

1. To test the h \_\_\_\_\_, they conducted several controlled experiments.
2. She decided to s \_\_\_\_\_ breakfast and have an early lunch instead.
3. It's easy to o \_\_\_\_\_ the importance of grades while neglecting the value of learning.

**Exercise 1** 어법

다음 글의 밑줄 친 부분 중, 어법상 틀린 것은?

25007-0049

Cooperation is a hallmark of human society. Not merely ① do people behave considerately toward complete strangers, they sometimes make substantial financial and even physical sacrifices for them. Such behavior seems impossible to explain with classic models of the evolution of altruism ② which cooperation between unrelated others can arise only when the same individuals interact repeatedly. However, new models of the evolution of human sociality and the results of experiments to test ③ them suggest that a sense of fairness and other foundations of morality have deep evolutionary roots. Such models consider processes at the level of groups of individuals, but without relying on the discredited notion of group selection in which individuals act “for the good of the group.” Genes promoting prosocial tendencies in individuals can arise when groups compete in ways ④ argued to be characteristic of the early stages of human evolution. In particular, such conditions may have promoted the evolution of *strong reciprocity*, a tendency to cooperate with anonymous unrelated others and ⑤ to punish those who do not do the same even when doing so is costly to the punisher.

\* altruism: 이타주의 \*\* anonymous: 익명의

**Sentence Structure**

- Such models consider processes at the level of groups of individuals, but without relying on the discredited notion of group selection [in which individuals act “for the good of the group”].

[ ]는 the discredited notion of group selection을 수식하는 관계절이다.

**Word Search** 주어진 문장에 들어갈 적절한 영어 단어를 본문에서 찾아 쓰시오. (필요시 형태를 바꿀 것)

1. **C** \_\_\_\_\_ between countries helps share food and supplies to fight world hunger.
2. His decision to return the lost wallet showed his strong sense of **m** \_\_\_\_\_.
3. The organization led a campaign to **p** \_\_\_\_\_ awareness of environmental issues.

## Exercise 2 주제 추론

다음 글의 주제로 가장 적절한 것은?

25007-0050

Deforestation drivers are very diverse and vary by countries and states. A number of important studies have attempted to generalise and pull together large numbers of local studies. This work is hampered, however, by the fact that most information on drivers is not quantitative, so that few direct quantitative correlations can be made linking certain quantities of deforestation to particular activities. Angelsen and Kaimowitz reviewed 140 economic models analysing the causes of tropical deforestation. They found that, when looking at proximate causes, deforestation is often associated with the presence of more roads, higher agricultural prices, lower wages, and a shortage of off-farm employment. Also they considered it likely that policy reforms associated with economic liberalisation and related adjustment increase the pressure on forests. They pointed out, however, that many research studies have adopted poor methodology and low quality data, which makes the drawing of clear conclusions about the role of macroeconomic factors difficult.

\* hamper: 어렵게 하다, 방해하다 \*\* proximate cause: 직접적인 원인

- ① difficulty of clearly attributing deforestation to specific causes
- ② ways of assessing the impact of deforestation on local economies
- ③ significance of interdisciplinary approaches in deforestation studies
- ④ necessity of preserving forest biodiversity for sustainable ecosystems
- ⑤ challenges in balancing economic development with environmental protection

### Sentence Structure

- Also they considered **it** likely [that policy reforms {associated with economic liberalisation and related adjustment} increase the pressure on forests].

it은 형식상의 목적어이고 [ ]가 내용상의 목적어이다. [ ] 안의 { }는 policy reforms를 수식한다.

**Word Search** 주어진 문장에 들어갈 적절한 영어 단어를 본문에서 찾아 쓰시오. (필요시 형태를 바꿀 것)

1. Do not **g** \_\_\_\_\_ one person's experience to everyone.
2. In engineering, **q** \_\_\_\_\_ data is used to make precise measurements and calculations.
3. An **a** \_\_\_\_\_ to the policy is required to deal with the issue better.

**Exercise 3** 제목 추론

다음 글의 제목으로 가장 적절한 것은?

25007-0051

On the one hand, the astonishing success of modern science in predicting and explaining the world seems to justify relying on it and bestowing extraordinary power to scientific institutions (especially in the form of public funding). On the other hand, the dominant societal position of science risks marginalizing alternative forms of knowledge acquisition. It's not clear that there still is a fair competition between science and its alternatives; and it's not straightforward that science has to prove its epistemic superiority in the 21st century in a way comparable to the period of the scientific revolution (16th-18th centuries). This is Paul Feyerabend's major argument in *Science in a Free Society*, which he casts as: "today science prevails not because of its comparative merits, but because the show has been rigged in its favour." So, Feyerabend insists, the fact that science has been the most appropriate means for addressing problems in the past doesn't warrant that it's also the most reliable form of knowledge acquisition for our current and future problems.

\* bestow: 부여하다 \*\* epistemic: 인식론적인 \*\*\* rig: 조작하다

- ① Integration of Science and Other Fields: A Must for Efficient Education
- ② Utilize Accumulated Scientific Knowledge to Thrive in Changing Times
- ③ From Lab to Society: Addressing the Gap in Science Communication
- ④ How Does Public Funding Undermine the Reliability of Science?
- ⑤ Is Science Still the Best Path to Knowledge?

**Sentence Structure**

- So, Feyerabend insists, the fact [that science has been the most appropriate means for addressing problems in the past] doesn't warrant [that it's also the most reliable form of knowledge acquisition for our current and future problems].

첫 번째 [ ]는 the fact의 구체적 내용을 설명하는 동격절이고, 두 번째 [ ]는 warrant의 목적어 역할을 하는 명사절이다.

**Word Search**

주어진 문장에 들어갈 적절한 영어 단어를 본문에서 찾아 쓰시오. (필요시 형태를 바꿀 것)

1. She tried to **j** \_\_\_\_\_ her actions by explaining the circumstances that led to her decision.
2. The lion is the **d** \_\_\_\_\_ animal in the African savanna.
3. During challenging times, it's important to believe that goodness will **p** \_\_\_\_\_.

## Exercise 4 어법

(A), (B), (C)의 각 네모 안에서 어법에 맞는 표현으로 가장 적절한 것은?

25007-0052

A hallmark of immigrant parents that has been found across socioeconomic groups and countries of origin (A) is / are that first-generation immigrant parents place a high value on the educational achievement of their adolescent children. Immigrant parents tend to view earning good grades, finishing high school, and attending college as the primary means (B) through which / which their children can establish themselves in their country of destination. Compared to native-born parents with similar education levels, immigrant parents have been found to have higher educational aspirations for their children. Immigrant adolescents internalize their parents' values regarding the importance of education and tend to study more and devote more effort to their schoolwork than (C) do / are nonimmigrant adolescents. During adolescence, immigrants' peer groups often become more segregated from nonimmigrants' peer groups, with the immigrant adolescents supporting their peers' academic achievement, particularly for higher SES (socioeconomic status) adolescents.

\* hallmark: 특징

- |   | (A) | (B)           | (C) |
|---|-----|---------------|-----|
| ① | is  | through which | do  |
| ② | is  | which         | do  |
| ③ | is  | through which | are |
| ④ | are | which         | are |
| ⑤ | are | through which | do  |

### Sentence Structure

- Compared to native-born parents with similar education levels, immigrant parents **have been found** to have higher educational aspirations for their children.

완료형 수동태 have been found가 쓰여 주어진 immigrant parents에 대한 특정 사실이 밝혀졌음을 나타낸다.

**Word Search** 주어진 문장에 들어갈 적절한 영어 단어를 본문에서 찾아 쓰시오. (필요시 형태를 바꿀 것)

- Many i families face unique challenges as they adjust to life in a new country.
- The young athlete has had a of competing in the Olympics since she was a child.
- Children often i the values and behaviors they observe from their parents.

## Exercise 5 무관한 문장

다음 글에서 전체 흐름과 관계 없는 문장은?

25007-0053

In public speaking, delivery with little or no preparation is called *impromptu speaking*. You engage in impromptu speaking every day as you communicate thoughts and ideas that spring up in the moment with no preparation or practice whatsoever. ① For example, when you answer a question in class or speak up during a meeting of a campus organization, you're using impromptu speaking. ② In this respect, impromptu speaking is simply another way to use the basic communication skills you already have and use regularly. ③ Learning how to express yourself on the spot without relying on research, extensive preparation, or notes will help you do well in your public speaking class and in less-structured speaking situations beyond the classroom. ④ This expertise stems from the fact that the speaker presents relevant information prepared with careful research that had been carried out specifically for the speech. ⑤ In addition, developing your impromptu speaking skills increases your confidence and decreases your speaking anxiety in any presentation context.

### Sentence Structure

- You engage in impromptu speaking every day [as you communicate thoughts and ideas {that spring up in the moment} with no preparation or practice whatsoever].

[ ]는 시간을 나타내는 부사절이고, 그 안의 { }는 thoughts and ideas를 수식하는 관계절이다.

**Word Search** 주어진 문장에 들어갈 적절한 영어 단어를 본문에서 찾아 쓰시오. (필요시 형태를 바꿀 것)

- Her research was so **e** \_\_\_\_\_ that it covered many different areas.
- She approached the job interview with **c** \_\_\_\_\_ because she had prepared thoroughly.
- Regular exercise can help **d** \_\_\_\_\_ the risk of heart disease.

## Exercise 6 글의 순서

주어진 글 다음에 이어질 글의 순서로 가장 적절한 것은?

25007-0054

In principle, there is an intuitively plausible relationship between profit and team quality. Fans like to watch exciting games where the outcome is uncertain. This is a result of competitive balance between the opponents.

- (A) Thus, improved team quality should translate into more wins and therefore increased attendance. With a given set of prices, increased attendance turns into increased revenue from gate receipts, parking, and concessions.
- (B) This increased revenue should lead to higher profit, but it costs more to field a higher-quality team than a lower-quality team. Consequently, there is a trade-off and therefore an optimal level of team quality that will vary from team to team depending on variation in the fan base.
- (C) Tight, hard-fought games are more fun to watch than lopsided games in which the outcome is never in doubt. However, fans also prefer to see their team win. As a result, attendance should increase with improvement in the team's performance. Presumably, better teams win more than weaker teams.

\* plausible: 그럴듯한 \*\* revenue: 수입 \*\*\* lopsided: 한쪽으로 기울

- ① (A) - (C) - (B)                      ② (B) - (A) - (C)                      ③ (B) - (C) - (A)  
 ④ (C) - (A) - (B)                      ⑤ (C) - (B) - (A)

### Sentence Structure

- Fans like [to watch exciting games {where the outcome is uncertain}].

[ ]는 like의 목적어 역할을 하는 to부정사구이고, 그 안의 { }는 exciting games를 수식하는 관계절이다.

**Word Search** 주어진 문장에 들어갈 적절한 영어 단어를 본문에서 찾아 쓰시오. (필요시 형태를 바꿀 것)

- The o \_\_\_\_\_ of today's election will be announced tomorrow morning.
- The temperatures can v \_\_\_\_\_ greatly between day and night in the desert.
- His performance on the test showed a clear i \_\_\_\_\_ from last time.

**Exercise 7** 어법

다음 글의 밑줄 친 부분 중, 어법상 틀린 것은?

25007-0055

The impacts that volcanoes can have on the weather can extend well beyond the eruption site; they are one of the largest drivers of climate change over geological timescales. The vast majority of the 65,500 billion tons of carbon on Earth is ① held within rocks. The remainder resides in the oceans, atmosphere, plants, soil and fossil fuels. Carbon dioxide inside Earth is released ② continually during volcanic eruptions, and before the Industrial Revolution volcanoes were the largest source of carbon dioxide entering Earth's atmosphere. However, the release of carbon is largely regulated by the natural carbon cycle, which draws down as much carbon from the atmosphere as volcanoes release into it, ③ acting as a planetary scale thermostat. If temperatures increase due to a period of intense volcanism, more carbon will be drawn down from the atmosphere, ④ it will take temperatures back to their previous levels. However, given the slow rate of some of these chemical reactions it can take hundreds of thousands of years for the system ⑤ to stabilize.

\* eruption: 분출, 분화 \*\* thermostat: 자동 온도 조절 장치

**Sentence Structure**

- However, the release of carbon is largely regulated by the natural carbon cycle, [which draws down {as much carbon from the atmosphere as volcanoes release into it}], acting as a planetary scale thermostat].  
 [ ]는 the natural carbon cycle을 부가적으로 설명하는 관계절이고, 그 안의 { }는 draws down의 목적어이다. { } 안에는 '...만큼 ~인'의 의미를 나타내는 「as much ~ as ...」가 사용되었으며, it은 문맥상 the atmosphere를 가리킨다.

**Word Search**

주어진 문장에 들어갈 적절한 영어 단어를 본문에서 찾아 쓰시오. (필요시 형태를 바꿀 것)

1. The g \_\_\_\_\_ formations in this region provide valuable insights into Earth's history.
2. The majority of the country's population r \_\_\_\_\_ in urban areas.
3. The i \_\_\_\_\_ heat wave caused widespread power outages across the nation.

## Exercise 8 주제 추론

다음 글의 주제로 가장 적절한 것은?

25007-0056

Ignacio Varchausky from the Buenos Aires tango orchestra El Arranque says in the documentary *Si Sos Brujo* that he and others tried learning from records how the older orchestras did what they did, but it was difficult, almost impossible. Eventually, El Arranque had to find the surviving players from those ensembles and ask them how it was done. The older players had to physically show the younger players how to replicate the effects they got, and which notes and beats should be emphasized. So, to some extent, music is still an oral (and physical) tradition, handed down from one person to another. Records may do a lot to preserve music and disseminate it, but they can't do what direct transmission does. In that same documentary, Wynton Marsalis says that the learning, the baton passing, happens on the bandstand — one has to play with others, to learn by watching and imitating. For Varchausky, when those older players are gone, the traditions (and techniques) will be lost if their knowledge is not passed on directly. History and culture can't really be preserved by technology alone.

\* ensemble: 합주단 \*\* disseminate: 전파하다

- ① the limitation of learning music indirectly through records
- ② efforts to preserve underappreciated music of artistic value
- ③ the tension between innovation and tradition in the music world
- ④ effects of musical education overly centered on direct transmission
- ⑤ conflicting views on the effectiveness of imitation in learning music

### Sentence Structure

- [Ignacio Varchausky from the Buenos Aires tango orchestra El Arranque] says in the documentary *Si Sos Brujo* [that he and others tried learning from records {how the older orchestras did what they did}, but it was difficult, almost impossible].

첫 번째 [ ]는 문장의 주어 역할을 하는 명사구이고, 두 번째 [ ]는 says의 목적어 역할을 하는 명사절이다. { }는 learning의 목적어 역할을 하는 명사절이다.

**Word Search** 주어진 문장에 들어갈 적절한 영어 단어를 본문에서 찾아 쓰시오. (필요시 형태를 바꿀 것)

1. Scientists struggled to r\_\_\_\_\_ the experiment's results in a different laboratory.
2. During the conference, she gave an impressive o\_\_\_\_\_ presentation on the impact of climate change on marine ecosystems.
3. The t\_\_\_\_\_ of cultural traditions from one generation to the next ensures their preservation.

**Exercise 9** 제목 추론

다음 글의 제목으로 가장 적절한 것은?

25007-0057

Teams have many communication technologies at their disposal, ranging from email and chat platforms to web conferencing and videoconferencing. People often default to using the tool that is most convenient or familiar to them, but some technologies are better suited to certain tasks than others, and choosing the wrong one can lead to trouble. Communication tools differ along a number of dimensions, including information richness (or the capacity to transfer nonverbal and other cues that help people interpret meaning) and the level of real-time interaction that is possible. A team’s communication tasks likewise vary in complexity, depending on the need to reconcile different viewpoints, give and receive feedback, or avoid the potential for misunderstanding. The purpose of the communication should determine the delivery mechanism. So carefully consider your goals. Use leaner, text-based media such as email, chat, and bulletin boards when pushing information in one direction — for instance, when circulating routine information and plans, sharing ideas, and collecting simple data. Web conferencing and videoconferencing are richer, more interactive tools better suited to complex tasks such as problem solving and negotiation, which require squaring different ideas and perspectives.

\* default to: ~을 기본적으로 선택하다 \*\* reconcile: 조화시키다 \*\*\* square: 조율하다, 맞추다

- ① Discover the Power of Purpose-driven Teamwork!
- ② Do Virtual Meetings Really Undermine Team Chemistry?
- ③ The Future of Work: Collaboration Redefined in the Digital Age
- ④ Match the Right Technology to Your Team’s Communication Goals
- ⑤ Fueling Innovation: The Magic of Teams with Diverse Personalities

**Sentence Structure**

- A team’s communication tasks likewise vary in complexity, depending on the need [to {reconcile different viewpoints}, {give and receive feedback}, or {avoid the potential for misunderstanding}].  
 [ ]는 the need의 구체적 내용을 설명하는 to부정사구이다. 세 개의 { }는 콤마(,)와 or로 연결되어 to에 이어진다.

**Word Search** 주어진 문장에 들어갈 적절한 영어 단어를 본문에서 찾아 쓰시오. (필요시 형태를 바꿀 것)

1. The new online p \_\_\_\_\_ facilitated discussions on various topics among users.
2. Further tests are needed to d \_\_\_\_\_ the exact cause of the patient’s illness.
3. The central bank is going to c \_\_\_\_\_ more money to stimulate the economy.

## Exercise 10 어법

다음 글의 밑줄 친 부분 중, 어법상 틀린 것은?

25007-0058

Animals regularly engage in future-oriented behaviors, from nest-building to hibernation. Clearly these behaviors are functionally prospective, but the extent to which they are controlled by cognitive processes ① remains an open question. Migrating birds, for example, travel long distances to avoid cold winters, without ever ② having experienced a winter, warmer climates, or the dangers of travel. These birds are unable to *know* ③ that it is they are avoiding and why this course of action benefits them. Indeed, when two bird populations with different migratory paths are cross-bred, the resulting offspring migrate in a direction halfway between that of their parents, ④ suggesting that direction of migration is genetically determined. From this example we can see that not all prospective behaviors can ⑤ be considered to involve awareness of the future, but may instead be automatic responses to natural (e.g., seasonal changes in day length or hormones), or learned, cues.

\* hibernation: 동면 \*\* cross-breed: 이종 교배하다 \*\*\* offspring: (동물의) 새끼

### Sentence Structure

- Indeed, [when two bird populations with different migratory paths are cross-bred], the resulting offspring migrate in a direction [halfway between **that** of their parents], ~.

첫 번째 [ ]는 접속사 when이 이끄는 부사절이다. 두 번째 [ ]는 a direction을 수식하고, that은 the direction을 대신한다.

**Word Search** 주어진 문장에 들어갈 적절한 영어 단어를 본문에서 찾아 쓰시오. (필요시 형태를 바꿀 것)

1. The young athlete's training program is a **p** \_\_\_\_\_ indicator of her future success in the competition.
2. Regular exercise has been shown to enhance **c** \_\_\_\_\_ function and improve memory.
3. Every winter, monarch butterflies **m** \_\_\_\_\_ thousands of miles to warmer climates.

**Exercise 11** 무관한 문장

다음 글에서 전체 흐름과 관계 없는 문장은?

25007-0059

Soil and the plants that grow in it are continually interacting in many ways, both directly and through the effects of the many kinds of bacteria, fungi and other small organisms that are always present. ① Most notably, plants are continually dropping leaves and other parts which fall to the ground to rot in place where they release their nutrients, although in some drier climates, lightning-set fires are necessary to liberate the mineral nutrients present in the plant litter. ② In any case, most of the nutrients present in dead plant material end up locally in the soil, while the vast networks of plant roots and fungal threads join with bacteria, lichens and sticky humus to effectively hold the soil together even in the face of heavy rains and strong winds. ③ The result is effective and continuous recycling of plant nutrients which are capable of moving back and forth between the soil and the plants almost indefinitely. ④ Methods for improving the quality of nutrient-poor soil include crop rotation and adding organic matter. ⑤ Soil is also a vast storehouse for the seeds and spores produced by the local plants, a key factor in allowing vegetation to regenerate following disturbance.

\* lichen: 지의류, 이끼   \*\* humus: 부식토   \*\*\* spore: 포자(식물이 무성 생식을 하기 위하여 형성하는 생식 세포)

**Sentence Structure**

- Most notably, plants are continually dropping leaves and other parts [which fall to the ground {to rot in place <where they release their nutrients>}], [although in some drier climates, lightning-set fires are necessary to liberate the mineral nutrients {present in the plant litter}].

첫 번째 [ ]는 leaves and other parts를 수식하는 관계절이다. 그 안의 { }는 결과의 의미를 나타내는 to부정사구이고, < >는 place를 수식하는 관계절이다. 두 번째 [ ]는 부사절이고, 그 안의 { }는 the mineral nutrients를 수식하는 형용사구이다.

**Word Search** 주어진 문장에 들어갈 적절한 영어 단어를 본문에서 찾아 쓰시오. (필요시 형태를 바꿀 것)

1. The soil lacked essential **n** \_\_\_\_\_, hindering the plant's growth.
2. The ocean was **v** \_\_\_\_\_, stretching far and wide with no end in sight.
3. Ecological **d** \_\_\_\_\_ can disrupt delicate ecosystems, leading to significant ecological imbalances.

## Exercise 12 글의 순서

주어진 글 다음에 이어질 글의 순서로 가장 적절한 것은?

25007-0060

When Darwin developed his theory of natural selection, he imagined evolution unrolling on geological timescales: the way a glacier sculpts a valley or weather beats on a rock, so time molds one species into another.

(A) The birds with the smallest and pointiest beaks were suddenly, and distinctly, advantaged. Their genes rapidly spread. Selection for traits can happen over the course of years or decades, not just eons. And Darwin's finches are exemplary, not exceptional. They are a privileged case of the paradigm that the biologist John Thompson has called "relentless evolution."

(B) It turns out that evolution works far more quickly than Darwin imagined. The finches of the Galápagos evolve on timescales we can observe. In 1983, for instance, a year with superabundant rainfall, a species of vine with tiny seeds overran the flora of Daphne Island.

(C) Such was the conventional wisdom for over a century. But in the late twentieth century, our understanding of evolution started to change, thanks in no small part to the continuing study of the Galápagos finches that Darwin himself had observed on the voyage of the *Beagle*.

\* eon: 10억 년 \*\* finch: 핀치(부리가 짧은 작은 새) \*\*\* flora: 식물군

① (A) - (C) - (B)

② (B) - (A) - (C)

③ (B) - (C) - (A)

④ (C) - (A) - (B)

⑤ (C) - (B) - (A)

### Sentence Structure

- But in the late twentieth century, our understanding of evolution started to change, [**thanks** {in no small part} **to** the continuing study of the Galápagos finches {that Darwin himself had observed on the voyage of the *Beagle*}].

[ ]의 thanks to는 '~ 덕분에, ~ 때문에'라는 의미이며, 첫 번째 { }가 thanks와 to 사이에 놓였다. 두 번째 { }는 the Galápagos finches를 수식하는 관계절이다.

**Word Search** 주어진 문장에 들어갈 적절한 영어 단어를 본문에서 찾아 쓰시오. (필요시 형태를 바꿀 것)

1. The sculptor's skilled hands can **m** \_\_\_\_\_ the clay into a breathtakingly lifelike figure.
2. The company decided to stick with **c** \_\_\_\_\_ methods rather than experimenting with new approaches.
3. The little girl was **o** \_\_\_\_\_ a butterfly flying from flower to flower.

**Exercise 1** 어법

다음 글의 밑줄 친 부분 중, 어법상 틀린 것은?

25007-0061

Profits are managed not only by setting a pricing strategy to maximize revenues and control costs; they are also influenced by a commitment to measure marketing performance. An organization cannot achieve its objectives if it does not know ① where it stands in meeting those objectives. Measurement of marketing activities is needed to assess past performance as well as ② set a future marketing strategy. For example, it is important for a minor league baseball team to understand the effectiveness of Saturday night fireworks promotions in terms of the number of additional tickets ③ sold and related spending from those customers. Tracking performance in this case would enable a comparison of revenue ④ generating with costs accumulated to execute the promotion. Such return on investment analysis should be performed whenever possible ⑤ to understand the relationship between marketing investment and profits, and guide decision-making for future marketing activities.

**Sentence Structure**

- Profits are managed not only by setting a pricing strategy [to {maximize revenues} and {control costs}]; ~.  
 [ ]는 선행하는 a pricing strategy를 수식하는 to부정사구이고, 그 안에서 두 개의 { }가 and로 연결되어 to에 이어진다.

**Word Search**

주어진 문장에 들어갈 적절한 영어 단어를 본문에서 찾아 쓰시오. (필요시 형태를 바꿀 것)

1. The nonprofit o \_\_\_\_\_ works to support underprivileged communities.
2. He finally a \_\_\_\_\_ his lifelong dream of becoming a published author.
3. His ability to m \_\_\_\_\_ the resources ensured the project was completed within the budget.

## Exercise 2 주제 추론

다음 글의 주제로 가장 적절한 것은?

25007-0062

Consider how some people, including some young children, enjoy doing jigsaw puzzles for hours. There are no big surprises. (Unless the last piece has been hidden by a sly sibling.) The players know exactly what the end result will look like and are rarely startled midway. But there can still be great satisfaction upon completion. When listening to an interesting story, we can be deeply disappointed if we don't get to hear the ending. When exploring a new place such as a house or a park, we often want to get a clear sense of the overall layout and can be frustrated if we don't know how different locations fit together. Infants, like all of us, strive to achieve closure. They have a need to identify *all* the toys that are in a box, or explore *every* room of a new space. They have similar needs for closure in their causal models of how things happen. This constellation of needs for closure often helps drive wonder, especially when there is a need to close an explanatory gap.

\* sly: 장난꾸러기의 \*\* closure: 완결감 \*\*\* constellation: (유사한 것의) 집합체

- ① effects of unpredictability in completing familiar tasks
- ② reasons why young children avoid facing new challenges
- ③ the absence of conclusion as a driving force behind education
- ④ the minor role of completion in the enjoyment of jigsaw puzzles
- ⑤ the inherent human drive for completion, prominent from childhood

### Sentence Structure

- The players [know exactly {what the end result will look like}] and [are rarely startled midway].  
두 개의 [ ]가 and로 연결되어 문장의 술부를 이루고 있고, 첫 번째 [ ]에서 { }는 what이 이끄는 명사절로 동사 know의 목적어 역할을 한다.

**Word Search** 주어진 문장에 들어갈 적절한 영어 단어를 본문에서 찾아 쓰시오. (필요시 형태를 바꿀 것)

1. He felt f\_\_\_\_\_ by his inability to solve the complex puzzle.
2. The l\_\_\_\_\_ of the resort made it a popular destination for tourists.
3. The parents were delighted as they watched their i\_\_\_\_\_ take his first steps.

**Exercise 3** 제목 추론

다음 글의 제목으로 가장 적절한 것은?

25007-0063

Unlike Europe’s national and partisan press, U.S. daily newspapers competed predominantly at the city level. The circulation range for a daily newspaper was primarily bounded by its distance from other cities and by its time of publication. Streetcars at the end of the 19th century, and motor trucks in the 20th permitted timely delivery of newspapers over larger regions. Different papers competing in the same towns chose to limit or spread out their physical distribution and editorial coverage to different radial distances from the central city. Morning newspapers printed during the night were, of course, able to distribute over a wider range than afternoon papers. By and large, however, the geographical area within which happenings were regularly reported as local news coincided with the area from which the newspaper drew the bulk of its readers.

\* partisan: 당파적인 \*\* radial distance: 반경 거리

- ① There Is No Commonality in European Newspapers
- ② Why Do All U.S. Newspapers Cover the Same Content?
- ③ Global Competition: U.S. Newspapers’ Editorial Strategies
- ④ Regional Focus: Characteristics of U.S. Daily Newspapers
- ⑤ Transportation Revolution, What Gave Birth to International Newspapers

**Sentence Structure**

- The circulation range for a daily newspaper was primarily bounded [by its distance from other cities] and [by its time of publication].

by가 이끄는 전치사구인 두 개의 [ ]는 and로 연결되어 was primarily bounded에 이어진다.

**Word Search** 주어진 문장에 들어갈 적절한 영어 단어를 본문에서 찾아 쓰시오. (필요시 형태를 바꿀 것)

- 1. Regular exercise can improve blood c \_\_\_\_\_.
- 2. Talented athletes c \_\_\_\_\_ in the international tournament.
- 3. The festival dates c \_\_\_\_\_ with the national holiday.

## Exercise 4 어법

(A), (B), (C)의 각 네모 안에서 어법에 맞는 표현으로 가장 적절한 것은?

25007-0064

Wind plays an important role in Earth's water cycle. In recent years, the once-accepted view of the water cycle has changed, and wind's role in atmospheric circulation has found greater appreciation. Traditionally, it was thought that the planet's water cycle mostly involved evaporated moisture from large bodies of water (A) **being / was** distributed by wind across the Earth's surface. In the last fifty years, that view has changed — it is now known that forests play a significant role in generating the transpiration that drives rainfall. The various plants that live within forests capture water in their roots, and then release (B) **it / them** as vapour through transpiration. Prevailing winds transport the water through the air, delivering rainfall to other locations. When this water moves through the power of wind in large volumes, it becomes (C) **what / that** meteorologist José Marengo called a 'flying river'.

\* transpiration: 증산 작용 \*\* prevailing wind: 탁월풍 \*\*\* meteorologist: 기상학자

- |   | (A)   |       | (B)  |       | (C)  |
|---|-------|-------|------|-------|------|
| ① | being | ..... | it   | ..... | what |
| ② | being | ..... | them | ..... | what |
| ③ | being | ..... | it   | ..... | that |
| ④ | was   | ..... | them | ..... | that |
| ⑤ | was   | ..... | it   | ..... | that |

### Sentence Structure

- ~ **it** is now known [that forests play a significant role in generating the transpiration {that drives rainfall}].  
it은 형식상의 주어이고, that이 이끄는 명사절인 [ ]가 내용상의 주어이다. { }는 the transpiration을 수식하는 관계절이다.

**Word Search** 주어진 문장에 들어갈 적절한 영어 단어를 본문에서 찾아 쓰시오. (필요시 형태를 바꿀 것)

1. The team received widespread **a** \_\_\_\_\_ for their hard work.
2. The air was thick with **m** \_\_\_\_\_ after the rain.
3. The **s** \_\_\_\_\_ of the lake was so clear that it perfectly reflected the surroundings.

**Exercise 5** 무관한 문장

다음 글에서 전체 흐름과 관계 없는 문장은?

25007-0065

Caregivers and others in a child's immediate surroundings affect the language being acquired by that child. Later, social groups affect the child's language. ① This results in social varieties of language with differences for class, ethnicity, and age as well as gender and gender expression. ② However, when a social group undergoes significant changes across generations leading to the need for a different type of communication, an earlier variety might cease to be used. ③ This occurred with the English initially spoken in Cosme and Nueva Australia, which were rural Paraguayan communities founded by Australian immigrants in the 1890s. ④ As a means of adapting to new cultural norms and enhancing its own communication and understanding, the English language makes extensive use of borrowings. ⑤ The only remaining language vestiges from those English-speaking immigrants are common Paraguayan last names like Kennedy, Smith, Stanley, and Wood.

\* vestige: 흔적, 자취

**Sentence Structure**

- However, [when a social group undergoes significant changes across generations {leading to the need for a different type of communication}], an earlier variety might cease to be used.  
 [ ]는 시간의 부사절이며, 그 안의 { }는 앞선 significant changes across generations를 수식하는 분사구이다.

**Word Search** 주어진 문장에 들어갈 적절한 영어 단어를 본문에서 찾아 쓰시오. (필요시 형태를 바꿀 것)

1. The design has to appeal to all ages and **s**\_\_\_\_\_ groups.
2. Due to the lack of use, some languages have gradually **c**\_\_\_\_\_ to be spoken eventually.
3. Various **c**\_\_\_\_\_ in the region worked together to preserve their traditions.

## Exercise 6 글의 순서

주어진 글 다음에 이어질 글의 순서로 가장 적절한 것은?

25007-0066

Pain is a neurological response to an external stimulus.

- (A) The excitement of the brain pain neurons in turn asserts a presence in our consciousness. We become aware of something being on our arm. If it is a bee sting, where the bee leaves poisonous liquids at the sting site, more neurons at the site of the sting are triggered than with a mosquito.
- (B) A mosquito bite, triggering a very small number of pain receptors, will create a mild sensation of awareness in the brain. The signal is relayed by a chain of neurons up the spine of the individual to a special place in the brain.
- (C) Therefore, a stronger signal is sent to the brain, with a stronger insertion into the individual's consciousness. If a falling tree crushes a leg then many, many pain receptors are fired off and the consciousness is overwhelmed with pain signals. Torn flesh will continuously fire the signal until medical treatment deals with the problem.

\* receptor: 수용기(受容器) \*\* spine: 척추

- ① (A) - (C) - (B)                      ② (B) - (A) - (C)                      ③ (B) - (C) - (A)  
 ④ (C) - (A) - (B)                      ⑤ (C) - (B) - (A)

### Sentence Structure

- If it is a bee sting, [where the bee leaves poisonous liquids at the sting site], **more** neurons at the site of the sting are triggered **than** with a mosquito.

[ ]는 a bee sting을 추가적으로 설명하는 관계절이고, 주절에는 「more ~ than ...」의 비교 구문이 사용되었다.

**Word Search** 주어진 문장에 들어갈 적절한 영어 단어를 본문에서 찾아 쓰시오. (필요시 형태를 바꿀 것)

1. The teacher's **r**\_\_\_\_\_ to the student's question helped clarify the lesson.
2. The traffic light turned green, giving the **s**\_\_\_\_\_ for the cars to start moving.
3. The **i**\_\_\_\_\_ of normal genes into the diseased cells could cure the disease.

## Exercise 7 어법

다음 글의 밑줄 친 부분 중, 어법상 틀린 것은?

25007-0067

Conflict is at the very heart of people-work, especially for professionals such as social workers, police and probation officers, who are often required to balance individual rights and freedoms against risks and harm to others. The very act of undertaking a risk assessment on an individual or family carries with it the likelihood of decisions being taken with which some of the people ① involved may violently disagree. To remove a child 'at risk' from a family to a place of safety, or ② to insist that someone in mental distress go into hospital for treatment, is to be involved in conflict. Within a multi-disciplinary hospital team, there could also be conflicting approaches to how to work most ③ effectively with, or treat, a particular individual or family. Most people-workers and healthcare workers can also give examples of times when they have had to deal with angry, distressed or disappointed people ④ whose response has often provoked high levels of conflict. To develop appropriate communication skills for dealing with conflict ⑤ being, therefore, essential.

\* probation: 보호 관찰

### Sentence Structure

- Conflict is at the very heart of people-work, especially for professionals such as social workers, police and probation officers, [who are often required to balance individual rights and freedoms against risks and harm to others].

[ ]는 professionals such as social workers, police and probation officers를 부가적으로 설명하는 관계절이다.

### Word Search

주어진 문장에 들어갈 적절한 영어 단어를 본문에서 찾아 쓰시오. (필요시 형태를 바꿀 것)

1. Professors both teach and u \_\_\_\_\_ research.
2. You need to conduct the initial a \_\_\_\_\_ defining the scope of work.
3. We sensed his deep emotional d \_\_\_\_\_.

## Exercise 8 주제 추론

다음 글의 주제로 가장 적절한 것은?

25007-0068

Drinking bypasses lots of our natural food control system. Just think how easy it is to drink a large glass of apple juice, yet you wouldn't sit down and eat eight apples in one sitting — after the second one, the control system would step in and say you have had enough. The whole apple contains fibre, which slows the release of the apple's sugar and, in doing so, balances the effect of eating it on our energy. Without the fibre in the juice, the sugar sends us on a rollercoaster of energy cycles, starting with a boost and ending in a crash. The crash may be just at the point when you are asked to stand up and present your ideas or you need to kick off that tricky task on your to-do list. It's just not worth it. Sugary caffeine drinks have a similar, if not more profound, effect, yet large coffee shop chains take great delight in selling us expensive, iced or cream-topped drinks that are equivalent to an extra meal, but will simply not register as one — starting a blood sugar crash cycle all over again.

\* bypass: 무시하다 \*\* equivalent to: ~에 상당하는

- ① essential roles of sugar in human physiology
- ② common myths about how fruits help our health
- ③ the impact of drinking sugary beverages on our body
- ④ understanding the factors helping nutrient absorption
- ⑤ how to balance the energy we take in and the energy we burn

### Sentence Structure

- The whole apple contains fibre, [which {slows the release of the apple's sugar} and, in doing so, {balances the effect of eating it on our energy}].

[ ]는 fibre를 부가적으로 설명하는 관계절이다. 두 개의 { }가 and로 연결되어 관계절의 술부를 구성한다.

**Word Search** 주어진 문장에 들어갈 적절한 영어 단어를 본문에서 찾아 쓰시오. (필요시 형태를 바꿀 것)

1. Eating enough **f** \_\_\_\_\_ can help waste to move smoothly through the body.
2. Passing the test was such a **b** \_\_\_\_\_ to my confidence.
3. This equipment was too **t** \_\_\_\_\_ to install.

Exercise 9 제목 추론

다음 글의 제목으로 가장 적절한 것은?

25007-0069

There are a lot of ways for an ad to go wrong. But its odds for success are increased by starting out with a smart, focused strategy. With such focus, the ad is able to deliver its singular message on the many levels in which advertising communicates. It bores down to make its point rather than making a big mess of itself. The chance for the reader to “get it” increases tremendously. The flip side is that an unfocused strategy leads to ads that must deliver many different points all at the same time. This is not effective. Here’s an analogy: Try throwing a dozen balls at someone all at once. It’s impossible to catch a single one. In fact, the impulse is to give up, shield your face, and try not to get hurt. Absolute chaos. But throw a single ball directly at the target and chances are, he or she will make the catch. That’s the difference between an ineffective ad with a fuzzy strategy and an effective ad with a focused strategy.

\* flip side: 이면 \*\* analogy: 비유, 유추 \*\*\* fuzzy: 모호한

- ① Navigating Responsibility in Advertising
- ② Ad Fusion: Blending Creativity with Data
- ③ Building Brand Loyalty Through Smart Ads
- ④ Understanding Consumer Behavior Through Ads
- ⑤ Importance of Crafting Focused Advertising Strategies

Sentence Structure

- With such focus, the ad is able to deliver **its** singular message on the many levels [in which advertising communicates].

its는 the ad를 가리키며, [ ]는 the many levels를 수식하는 관계절이다.

Word Search 주어진 문장에 들어갈 적절한 영어 단어를 본문에서 찾아 쓰시오. (필요시 형태를 바꿀 것)

1. He had a sudden **i**\_\_\_\_\_ to stand up and dance.
2. This video **d**\_\_\_\_\_ a clear message about water safety.
3. The **o**\_\_\_\_\_ of finding a parking space are very low.

## Exercise 10 어법

다음 글의 밑줄 친 부분 중, 어법상 틀린 것은?

25007-0070

We are all able to think of words which have changed their meanings, or ① acquired additional meanings, in our own lifetimes, such as the changes in the use of words like chip, grass, joint and hardware. This demonstrates how words are mere labels for constructs of meanings. If these constructs have a different make-up from one person to another, the transitivity of communication between them ② is not going to be complete or accurate. For those who are learning English as an additional language, apprehension of English forms and structures, and their meanings may pose difficulties, or even may be tinged with aspects of meaning from the characteristics ③ owned by the native tongue. Gradually, with full fluency and the commerce of using the language, commonality of understanding will be ④ generally achieved. However, it is important for those teaching children at early stages of the acquisition of English in our schools ⑤ attend to building the understanding of meanings behind the labels of the words and phrases being taught.

\* transitivity: 이행, 전이, 전달 \*\* tinge: 가미하다

### Sentence Structure

- We are all able to think of words [which have {changed their meanings}, or {acquired additional meanings}, in our own lifetimes], such as the changes in the use of words like chip, grass, joint and hardware.  
[ ]는 words를 수식하는 관계절이고, 두 개의 { }가 or로 연결되어 have에 이어진다.

**Word Search** 주어진 문장에 들어갈 적절한 영어 단어를 본문에서 찾아 쓰시오. (필요시 형태를 바꿀 것)

1. A \_\_\_\_\_ measurements are essential for maintaining safety.
2. A full a \_\_\_\_\_ of all that is involved is utterly beyond the scientists.
3. Language a \_\_\_\_\_ means the process of learning and understanding a language by a child or adult.

**Exercise 11** 무관한 문장

다음 글에서 전체 흐름과 관계 없는 문장은?

25007-0071

Many of us are prone to wanting instant gratification: constantly buying new clothes to be ‘trendy’, wanting the latest thing to ‘keep up’ or seeking immediate results or pleasure. Even though choosing something now may feel good in the moment, taking a longer-term view and developing self-discipline can result in bigger and better rewards in the future. ① Delayed gratification is our ability to resist these temptations of instant pleasure, allowing us to stay focused on our long-term goals. ② It’s important to have a big-picture goal, but it’s the significant short-term goals that get you to the end result. ③ It involves budgeting and spending mindfully, as well as developing discipline and patience to avoid impulse spending and decision making. ④ Think about instant vs delayed gratification when you are developing your own financial goals. ⑤ Consider whether your goals are focused on short-term gains or designed to look forward to a bigger picture.

\* gratification: 만족

**Sentence Structure**

- Even though [choosing something now] may feel good in the moment, [taking a longer-term view] and [developing self-discipline] can result in bigger and better rewards in the future.

첫 번째 [ ]는 부사절의 주어 역할을 하는 동명사구이다. 두 번째와 세 번째 [ ]는 동명사구로 and로 연결되어 주절의 주어 역할을 한다.

**Word Search** 주어진 문장에 들어갈 적절한 영어 단어를 본문에서 찾아 쓰시오. (필요시 형태를 바꿀 것)

1. His new novel was an i \_\_\_\_\_ hit.
2. An expensive jewelry is a t \_\_\_\_\_ to thieves.
3. It takes a lot of d \_\_\_\_\_ to stay away from snacks.

## Exercise 12 글의 순서

주어진 글 다음에 이어질 글의 순서로 가장 적절한 것은?

25007-0072

Uncertainty about what tool or procedure to use, and the risk that results are not what they appear to be, are problems common to all the scientific disciplines.

- (A) Waffling is annoying when you are trying to make decisions on the basis of the scientific information that comes your way. However, if a new technique is the source of the uncertainty, time and future experiments will confirm or disconfirm its usefulness and clear up uncertainty.
- (B) The development of new tools allows scientists to answer questions they could not answer in the past, and the answers to those questions will lead to new questions, and so on. Therefore, new technologies and procedures are crucial to the progress of science.
- (C) At the same time, other scientists unfamiliar with a new tool may express skepticism and call for others to replicate the experiments. Because this skepticism often comes to us in the form of sound bites, and because uncertainty about experimental tools is an aspect of science that is not familiar to most people, even people with a bachelor's degree in science, the skepticism may seem like waffling.

\* waffle: (결정을 못 내리고) 미적거리다 \*\* skepticism: 회의적인 태도, 회의론  
\*\*\* sound bites: 짧고 기억에 남기 쉬운 한두 문장으로 요약된 말

- ① (A) - (C) - (B)                      ② (B) - (A) - (C)                      ③ (B) - (C) - (A)  
④ (C) - (A) - (B)                      ⑤ (C) - (B) - (A)

### Sentence Structure

- [Uncertainty about what tool or procedure to use, and the risk {that results **are** not <what they appear to be>}], **are** problems common to all the scientific disciplines.

[ ]는 문장의 주어이고, 두 번째 are가 문장의 동사이다. { }는 the risk와 동격 관계에 있고, < >는 주격 보어이다.

**Word Search** 주어진 문장에 들어갈 적절한 영어 단어를 본문에서 찾아 쓰시오. (필요시 형태를 바꿀 것)

1. There is a good deal of u \_\_\_\_\_ about the exact path of the typhoon.
2. His most a \_\_\_\_\_ habit was eating with his mouth open.
3. X-rays have c \_\_\_\_\_ that she has not broken any bones.

**Exercise 1** 어법

다음 글의 밑줄 친 부분 중, 어법상 틀린 것은?

25007-0073

It is not uncommon for children to report overconfidence about accomplishing difficult tasks. Even when they are given feedback indicating that they have performed ① poorly, their self-efficacy may not decline. The incongruence between children's self-efficacy and their actual performance can arise when children lack task familiarity and do not fully understand ② what is required to execute a task successfully. As they gain experience, their accuracy improves. Children may also be excessively swayed by certain task features and ③ decide based on these that they can or cannot perform the task. In subtraction, for example, children may focus on how many numbers or columns the problems contain and judge problems with fewer columns as less difficult than ④ those with more columns, even when the former are conceptually more difficult. This is an instance where higher self-efficacy is problematic because students feel unrealistically overconfident and not motivated to seek help and improve their skills. As children's capability to focus on multiple features improves, so ⑤ is their accuracy.

\* incongruence: 불일치 \*\* sway: 영향을 주다 \*\*\* subtraction: 뺄셈

**Sentence Structure**

- **It is not uncommon** [{for children} to report overconfidence about {accomplishing difficult tasks}].  
It은 형식상의 주어이고, [ ]는 내용상의 주어이다. 그 안에서 첫 번째 { }는 to부정사구의 의미상의 주어를 나타내고, 두 번째 { }는 전치사 about의 목적어 역할을 하는 동명사구이다.

**Word Search** 주어진 문장에 들어갈 적절한 영어 단어를 본문에서 찾아 쓰시오. (필요시 형태를 바꿀 것)

1. Even with repeated failures, his enthusiasm did not **d** \_\_\_\_\_.
2. Young children often **l** \_\_\_\_\_ the experience needed to assess their abilities.
3. Her **c** \_\_\_\_\_ to solve complex problems makes her an asset to the team.

## Exercise 2 주제 추론

다음 글의 주제로 가장 적절한 것은?

25007-0074

Using generative AI in the hiring process still has its challenges and limitations. Generative AI may, for instance, produce inaccurate or misleading content that could harm the reputation or credibility of recruiters or candidates. It may also raise ethical or legal issues regarding data privacy, consent, or ownership. Thus, complete automation seems unlikely in the current field as hiring managers, legal departments, etc., still have to review and sign off on generated job ads and candidate communication. Therefore, generative AI should not replace human judgment or interaction in hiring but rather complement it. Generative AI should be used as a tool to augment human capabilities and creativity, not to automate them entirely. Recruiters should always verify the information and edit the content generated by generative AI before using it. They have to monitor the performance and impact of generative AI on their hiring outcomes and candidate experience.

\* augment: 증강하다

- ① the crucial role AI plays in shaping the future job market
- ② the evolving legal frameworks surrounding AI use in candidate selection
- ③ the inevitable shift toward fully automating recruitment using generative AI
- ④ the technological advancements leading to the replacement of human roles with AI
- ⑤ the need for human participation in integrating generative AI into the hiring process

### Sentence Structure

- Therefore, generative AI should **not** [replace human judgment or interaction in hiring] **but rather** [complement it].  
두 개의 [ ]가 '~이 아니라 오히려 ...인'이라는 의미의 「not ~ but rather ...」 구문으로 연결되었으며, it은 human judgment or interaction in hiring을 가리킨다.

**Word Search** 주어진 문장에 들어갈 적절한 영어 단어를 본문에서 찾아 쓰시오. (필요시 형태를 바꿀 것)

1. The company faced an **e** \_\_\_\_\_ dilemma when deciding whether to use animal testing for their new product.
2. Clear and concise **c** \_\_\_\_\_ is essential during a crisis to prevent misinformation.
3. The new regulations had a significant **i** \_\_\_\_\_ on the company's operations.

**Exercise 3** 제목 추론

다음 글의 제목으로 가장 적절한 것은?

25007-0075

Having asked the class a question, the average American teacher typically waits less than a second before picking a child to provide an answer — sending out a strong message that speed is valued over complex thinking. But a study from the University of Florida has found that something magical happens when the teacher takes a little more time — just three seconds — to wait to pick a child, and then for the child to think about the response. The most immediate benefit was seen in the length of the children’s answers. The small amount of thinking time meant that the children spent between three and seven times as long elaborating their thoughts, including more evidence for their viewpoint and a greater consideration of alternative theories. The increased waiting time also encouraged the children to listen to each other’s opinions and develop their ideas. Encouragingly, their more sophisticated thinking also translated to their writing, which became more nuanced and complex. That’s an astonishing improvement from the simple act of exercising teacherly patience. As the researcher Mary Budd Rowe put it in her original paper: ‘slowing down may be a way of speeding up’.

\* nuanced: 미묘한 차이가 있는

- ① How Do Classroom Environments Affect Learning Skills?
- ② Why Active Participation Enhances Student Comprehension
- ③ Questions: The Key to Unlocking Deeper Thinking in Students
- ④ The Power of Pause: How Waiting Can Deepen Student Thinking
- ⑤ Fast-paced Learning: Encouraging Instant Understanding in Students

**Sentence Structure**

- The small amount of thinking time meant [that the children spent between three and seven times as long elaborating their thoughts, {including more evidence for their viewpoint and a greater consideration of alternative theories}].

[ ]는 meant의 목적어 역할을 하는 명사절이며, 그 안의 { }는 elaborating their thoughts에 대한 부가적인 정보를 더해 주는 전치사구이다.

**Word Search**

주어진 문장에 들어갈 적절한 영어 단어를 본문에서 찾아 쓰시오. (필요시 형태를 바꿀 것)

1. The a \_\_\_\_\_ temperature this month has been unusually high for the season.
2. Her i \_\_\_\_\_ reaction to the news was one of surprise and excitement.
3. The coach’s motivational speech was meant to e \_\_\_\_\_ the team before the big game.

## Exercise 4 어법

(A), (B), (C)의 각 네모 안에서 어법에 맞는 표현으로 가장 적절한 것은?

25007-0076

There is little hope of finding high grade sources of minerals other than those we know already. The planet's crust has been thoroughly (A) exploring / explored and digging deeper is not likely to help, since ores form mainly because of hydrothermal processes that operate near the surface. The oceanic floor is geologically too recent for containing ores; only the sea floor near the continents could be a useful source of minerals. The oceans themselves contain metal ions, but extracting rare metals from seawater is out of the question (B) because / because of their minute concentrations that make the process highly expensive in energy terms. In addition, the amounts dissolved are not very large. For instance, considering the concentration of copper in the oceans we can calculate (C) that / what the total amount dissolved corresponds to 10 years of the present mine production. Some suggest outer space as a source of minerals but the energy cost of leaving earth is a major barrier. Then, most bodies of the solar systems — e.g., the Moon and the asteroids — are geochemically “dead” and contain no ores.

\* ore: 광물 \*\* hydrothermal: 열수(고온의 물) 작용의 \*\*\* asteroid: 소행성

- |             | (A)   |  | (B)        |       | (C)  |
|-------------|-------|--|------------|-------|------|
| ① exploring | ..... |  | because    | ..... | that |
| ② explored  | ..... |  | because    | ..... | that |
| ③ explored  | ..... |  | because of | ..... | that |
| ④ explored  | ..... |  | because of | ..... | what |
| ⑤ exploring | ..... |  | because of | ..... | what |

### Sentence Structure

- There is little hope of [finding high grade sources of minerals other than **those** we know already].  
[ ]는 hope와 동격 관계이며, those는 high grade sources of minerals를 대신한다.

**Word Search** 주어진 문장에 들어갈 적절한 영어 단어를 본문에서 찾아 쓰시오. (필요시 형태를 바꿀 것)

- The ocean **f** \_\_\_\_\_ is a territory that hasn't been fully explored yet.
- Before being turned in, the package must **c** \_\_\_\_\_ every necessary paper.
- Sugar will **d** \_\_\_\_\_ quickly in hot water, creating a sweet solution.

**Exercise 5** 무관한 문장

다음 글에서 전체 흐름과 관계 없는 문장은?

25007-0077

When we apply a simple technological solution to a problem that is actually nested within a complex biological system, we cannot easily predict how the system will adapt to the technology. ① In fact, if we don't understand how the "problem" is linked to or supported by the ecosystem, then we are defining the problem in human terms without understanding its biological or ecological foundation. ② For example, we have used synthetic pesticides to control unwanted insect pests in agriculture since the late 1940s. ③ Each and every pesticide that has been in common and widespread use has resulted in the evolution of resistant pest species, and this has resulted in a constant search for replacement pesticides as a countermeasure. ④ As the development of new pesticides has progressed, crop yields have significantly increased, improving global food supply stability. ⑤ This back and forth battle to control a biological problem with a technological solution has no ending point and is the result of an unwillingness on the human side to recognize the underlying issue.

\* synthetic pesticide: 합성 살충제

**Sentence Structure**

- When we apply a simple technological solution to a problem [that is actually nested within a complex biological system], we cannot easily predict [how the system will adapt to the technology].  
 첫 번째 [ ]는 a problem을 수식하는 관계절이고, 두 번째 [ ]는 predict의 목적어 역할을 하는 명사절이다.

**Word Search** 주어진 문장에 들어갈 적절한 영어 단어를 본문에서 찾아 쓰시오. (필요시 형태를 바꿀 것)

1. The discovery of a new fossil could l \_\_\_\_\_ modern birds to their ancestors.
2. The f \_\_\_\_\_ of trust is essential for building strong relationships.
3. The e \_\_\_\_\_ of fashion reflects changing cultural values.

## Exercise 6 글의 순서

주어진 글 다음에 이어질 글의 순서로 가장 적절한 것은?

25007-0078

Psychiatry is often viewed as medicine's 'poor cousin', and there are good reasons for this.

- (A) However, our understanding of how the human brain works as a whole still remains far from clear, and as a consequence, drug treatments for mental disorders have often been far from inspiring, with even the mechanisms of action of those drugs that do seem to have a positive impact on mental health remaining obscure.
- (B) This lack of clarity is due to the brain being so much more complex than any other organ in the body, but it also reflects the fact that human conscious awareness is as much a social as a biological entity, and therefore human mental disorders have a major social input.
- (C) During the past century, our understanding of bodily mechanisms has advanced through scientific understanding on a whole number of different fronts and led to important new drug treatments in areas as diverse as cardiology, cancer therapy, and treatment of bacterial and infectious diseases.

\* psychiatry: 정신의학 \*\* obscure: 모호한 \*\*\* cardiology: 심장학

- ① (A) - (C) - (B)                      ② (B) - (A) - (C)                      ③ (B) - (C) - (A)  
 ④ (C) - (A) - (B)                      ⑤ (C) - (B) - (A)

### Sentence Structure

- However, our understanding of [how the human brain works as a whole] still remains far from clear, and as a consequence, drug treatments for mental disorders have often been far from inspiring, [**with even the mechanisms of action of those drugs** {that do seem to have a positive impact on mental health} **remaining obscure**].

첫 번째 [ ]는 전치사 of의 목적어 역할을 하는 명사절이다. 두 번째 [ ]는 「with + 명사구 + 분사구」의 형태로 앞선 절의 부수적 상황을 표현하며, 그 안의 { }는 those drugs를 수식하는 관계절이다.

**Word Search** 주어진 문장에 들어갈 적절한 영어 단어를 본문에서 찾아 쓰시오. (필요시 형태를 바꿀 것)

1. Despite extensive research, many aspects of the disease still **r**\_\_\_\_\_ poorly understood.
2. The brain is the most complex **o**\_\_\_\_\_ in the human body.
3. Early **t**\_\_\_\_\_ of the disease can significantly improve outcomes for patients.

**Exercise 7** 어법

다음 글의 밑줄 친 부분 중, 어법상 틀린 것은?

25007-0079

When our brains encounter something unfamiliar or potentially dangerous, we quickly shift to *fight-or-flight response*, in which all of our mental (and sometimes physical) energy is devoted to ① addressing the perceived threat. Researchers at Harvard Medical School have done extensive research into this response and found that when ② faced with information that feels unknown or threatening, our brains send out a distress signal to the rest of the body through the autonomic nervous system, “which controls such involuntary body functions as breathing, blood pressure, heartbeat, and the dilation or constriction of key blood vessels and small airways.” These physical responses can be uncomfortable or even ③ painful, but more importantly they then trigger emotions that end up guiding our decision-making. We all know what it’s like to shake our heads and think, “I’d be so much smarter than that,” while watching the main character in a horror movie ④ makes a bafflingly terrible decision in the face of extreme danger. Chances are, however, we wouldn’t be smarter. In fight-or-flight mode, the part of our brain that takes over is only horror-movie-level smart, ⑤ which isn’t very smart at all.

\* dilation: 확장(증) \*\* constriction: 수축(증) \*\*\* bafflingly: 당황스럽게

**Sentence Structure**

- ~, but more importantly they then trigger emotions [that **end up guiding** our decision-making].  
[ ]는 emotions를 수식하는 관계절이다. 「end up + -ing」는 ‘결국 ~하게 되다’라는 의미이다.

**Word Search**

주어진 문장에 들어갈 적절한 영어 단어를 본문에서 찾아 쓰시오. (필요시 형태를 바꿀 것)

1. The growing **t** \_\_\_\_\_ of cybersecurity attacks has made companies spend a lot more on better security measures.
2. Exposure to bright flashing lights can **t** \_\_\_\_\_ severe headaches and discomfort in some people.
3. He was unable to walk any further due to **e** \_\_\_\_\_ fatigue.

## Exercise 8 주제 추론

다음 글의 주제로 가장 적절한 것은?

25007-0080

In today's digitally dynamic landscape, consumer behavior and experience play crucial roles in shaping the success of businesses across industries. The advent of artificial intelligence (AI) has revolutionized the way companies understand, analyze, and respond to consumer needs. Through the amalgamation of advanced algorithms, machine learning, and data analytics, AI offers a profound opportunity to delve deeper into consumer behaviors, providing invaluable insights that facilitate personalized experiences and foster long-term relationships. Understanding consumer behavior lies at the heart of any successful business strategy. AI, with its ability to process vast amounts of data in real time, allows for a comprehensive understanding of consumer preferences, habits, and tendencies. By analyzing past behaviors and interactions, AI identifies patterns that might escape traditional analysis, enabling businesses to anticipate future needs and tailor offerings accordingly. Whether it's predicting purchase patterns, understanding browsing behaviors, or understanding sentiment through social media interactions, AI-driven insights empower businesses to fine-tune their strategies for maximum impact.

\* amalgamation: 융합, 합병 \*\* delve into: ~을 철저하게 조사하다 \*\*\* sentiment: 감정, 정서

- ① challenges and constraints in applying AI-driven analytics
- ② ways of meeting the evolving demands of social media users
- ③ the need for ethical regulations surrounding the use of AI in businesses
- ④ the overestimated importance of data in developing effective marketing strategies
- ⑤ the critical role of AI in enhancing consumer understanding and driving profitability

### Sentence Structure

- [Through the amalgamation of advanced algorithms, machine learning, and data analytics], AI offers a profound opportunity [to delve deeper into consumer behaviors], [providing invaluable insights {that facilitate personalized experiences and foster long-term relationships}].

첫 번째 [ ]는 전치사구이며, 두 번째 [ ]는 a profound opportunity의 내용을 구체적으로 설명하는 to부정사구이다. 세 번째 [ ]는 분사구문으로 앞선 절의 내용을 부가적으로 설명하며, 그 안의 { }는 invaluable insights를 수식하는 관계절이다.

**Word Search** 주어진 문장에 들어갈 적절한 영어 단어를 본문에서 찾아 쓰시오. (필요시 형태를 바꿀 것)

1. The scientist developed an **a** \_\_\_\_\_ heart to help patients with heart failure.
2. The Internet has **r** \_\_\_\_\_ global communication, shrinking distances and connecting cultures.
3. His speech had a **p** \_\_\_\_\_ impact on the audience.

**Exercise 9** 제목 추론

다음 글의 제목으로 가장 적절한 것은?

25007-0081

One of the key constraints on the development of sports tourism prior to the nineteenth century was the lack of suitable transport. There were incremental improvements from the fifteenth century onwards involving more comfortable coaches and, in the eighteenth century, greatly improved roads, at least in Britain if not everywhere in Europe. But transport was primarily slow and costly. For example, the journey time from London to Bath in 1680, a distance of 107 miles, was around sixty hours. Vastly improved roads had cut this time to ten hours by 1800 but the time and cost still meant that only the wealthy in society could travel substantial distances. It was not until the development of the railways in the nineteenth century that a relatively cheap and efficient form of transport was afforded to the population at large, enabling sports tourism to develop beyond the small and exclusive upper class activity that had existed hitherto. As Wray Vamplew points out, the railways ‘revolutionized sport in England by widening the catchment area for spectators and by enabling participants to compete nationally’.

\* incremental: 점진적인 \*\* hitherto: 그때까지 \*\*\* spectator: 관중

- ① Regional Differences in Early Sports Tourism Practices
- ② Transport Breakthroughs: Decreasing the Cost of Traveling
- ③ The Influence of Local Rivalries on the Actions of Sports Fans
- ④ How Transport Advances Brought Change to Sports Tourism in England
- ⑤ Shift from Expensive Upper-class Travel Options to More Affordable Ones

**Sentence Structure**

- **It was not until** [the development of the railways in the nineteenth century] **that** [a relatively cheap and efficient form of transport was afforded to the population at large, {enabling sports tourism to develop beyond the small and exclusive upper class activity <that had existed hitherto>}].

‘It was not until A that B’ 구문이 사용되어 ‘A하고 나서야 비로소 B했다’라는 의미를 나타내는데, 두 개의 [ ]가 각각 A와 B에 해당한다. 두 번째 [ ] 안에서 { }는 분사구문으로 앞의 내용을 추가적으로 설명하고 < >는 the small and exclusive upper class activity를 수식하는 관계절이다.

**Word Search**

주어진 문장에 들어갈 적절한 영어 단어를 본문에서 찾아 쓰시오. (필요시 형태를 바꿀 것)

1. Due to a financial **c** \_\_\_\_\_, the non-profit had to cut back on several planned activities.
2. She received **s** \_\_\_\_\_ recognition for her pioneering research in neuroscience.
3. The new scheduling system is more **e** \_\_\_\_\_, reducing the time it takes to coordinate meetings.

## Exercise 10 어법

다음 글의 밑줄 친 부분 중, 어법상 틀린 것은?

25007-0082

Cambridge biologist William Hamilton studied the social behaviour of ants and wondered to himself not only why they often sacrificed ① themselves for their nestmates, but also how it was that sterile worker ants might have arisen, given these females don't breed but rather leave this to the queen. Hamilton solved this problem when he realised ② that, due to their particular method of breeding, these sterile worker ants share 75 per cent of their genes with their sisters. Hamilton then began to consider a 'gene's eye view' of natural selection, and immediately realised such non-queen worker ants could actually pass on a larger proportion of their genes indirectly by, instead of breeding themselves, ③ helped to raise their younger sisters. For each sister raised, they are passing on 75 per cent of their genes rather than the 50 per cent that would be ④ passed on via normal sexual reproduction. To Hamilton, ant colonies should really be perceived as a form of extended family ⑤ where the genetic interests of all are served by the apparent altruistic behaviour of some.

\* sterile: 불임의 \*\* altruistic: 이타적인

### Sentence Structure

- For each sister [raised], they are passing on 75 per cent of their genes rather than the 50 per cent [that would be passed on via normal sexual reproduction].

첫 번째 [ ]는 each sister를 수식하는 분사이고, 두 번째 [ ]는 the 50 per cent를 수식하는 관계절이다. the 50 per cent 뒤에는 of their genes가 생략된 것으로 이해할 수 있다.

**Word Search** 주어진 문장에 들어갈 적절한 영어 단어를 본문에서 찾아 쓰시오. (필요시 형태를 바꿀 것)

1. She's had to **s** \_\_\_\_\_ a lot for her family.
2. Many animals **b** \_\_\_\_\_ only at certain times of the year.
3. A large **p** \_\_\_\_\_ of income is spent on housing in urban areas.

**Exercise 11** 무관한 문장

다음 글에서 전체 흐름과 관계 없는 문장은?

25007-0083

The most common justification for a move to autonomous vehicles could well be called the argument from safety: the implementation of driving automation systems will reduce the risk of death or injury from automobile accidents. ① The basic premise seems reasonable enough: humans behind the wheel can be unreliable and, all too often, distracted, tired, or otherwise affected. ② This fallibility of human drivers no doubt contributes to a rate of injury and fatality that, in other contexts, would be considered a public health crisis. ③ Driving automation systems, by contrast, are supposed to be more reliable and, depending on the overall prevalence of autonomous vehicles and of the infrastructure to support them, may be able to coordinate with other vehicles to avoid accidents and other problems. ④ Despite the promise of safety, ethical concerns also arise regarding the use of autonomous vehicles, resulting in increased protests against their use. ⑤ On these premises, and assuming the new technology functions as advertised, it only makes sense to replace an unstable and unreliable human control system for something demonstrably better.

\* autonomous: 자율 주행의, 자율의 \*\* premise: 전제 \*\*\* fallibility: 불완전성

**Sentence Structure**

- The most common justification [for a move to autonomous vehicles] could well be called the argument from safety: [the implementation of driving automation systems will reduce the risk of death or injury from automobile accidents].

첫 번째 [ ]는 The most common justification을 수식하는 전치사구이다. 두 번째 [ ]는 the argument from safety의 구체적인 내용을 나타낸다.

**Word Search**

주어진 문장에 들어갈 적절한 영어 단어를 본문에서 찾아 쓰시오. (필요시 형태를 바꿀 것)

1. His j \_\_\_\_\_ for the new policy was based on detailed data analysis and expert recommendations.
2. The i \_\_\_\_\_ of the new educational curriculum was a complex process that involved several parties.
3. The rise in the f \_\_\_\_\_ rate is caused by a number of factors.

## Exercise 12 글의 순서

주어진 글 다음에 이어질 글의 순서로 가장 적절한 것은?

25007-0084

Most students can provide numerous examples of common sense, such as never putting a fork into an electrical outlet, not sticking your tongue on a pole covered with ice or placing your hands in boiling water, avoiding looking directly into the sun, and not attempting to attend a state dinner at the White House without an invitation.

- (A) Experience teaches us to act routinely in most social situations. Before long, such expectations come to be viewed as common sense.
- (B) And yet, none of these examples of common sense represents knowledge that we were born with; instead, we have learned all these things. The sociological perspective emphasizes that knowledge is gained through trial and error, experience, and the influences of others in the social environment.
- (C) However, because each of us has unique social experiences, we come to view common sense differently — we see it from our unique perspective. Thus, if one has not been exposed to a particular behavior — labeled by some as commonsense knowledge — one is not capable of acting in an obvious, or routine, manner.

\* outlet: 콘센트

- ① (A) - (C) - (B)                      ② (B) - (A) - (C)                      ③ (B) - (C) - (A)  
 ④ (C) - (A) - (B)                      ⑤ (C) - (B) - (A)

### Sentence Structure

- The sociological perspective emphasizes [that knowledge is gained through {trial and error}, {experience}, and {the influences of others in the social environment}].

[ ]는 emphasizes의 목적어 역할을 하는 명사절이고, 세 개의 { }는 콤마와 and에 의해 대등하게 연결되어 through에 공통으로 이어진다.

**Word Search** 주어진 문장에 들어갈 적절한 영어 단어를 본문에서 찾아 쓰시오. (필요시 형태를 바꿀 것)

- The **e** \_\_\_\_\_ among fans was high as the team had been performing well all season.
- The program is designed to **e** \_\_\_\_\_ students to various scientific fields.
- It was **o** \_\_\_\_\_ to everyone in the room that the speaker was unprepared, as evidenced by his frequent pauses and nervous attitude.

**Exercise 1** 어법

다음 글의 밑줄 친 부분 중, 어법상 틀린 것은?

25007-0085

Emotion categories, in my view, ① are made real through collective intentionality. To communicate to someone else that you feel angry, both of you need a shared understanding of “Anger.” If people agree that a particular combination of facial actions and cardiovascular changes ② is anger in a given context, then it is so. You needn’t be explicitly aware of this agreement. You don’t even have to agree ③ whether a particular instance is anger or not. You just have to agree in principle that anger exists with certain functions. At that point, people can transmit information about that concept among themselves so ④ efficient that anger seems inborn. If you and I agree that a furrowed brow indicates anger in a given context, and I furrow my brow, I am efficiently sharing information with you. My movement itself does not carry anger to you, any more than vibrations in the air carry sound. By virtue of the fact ⑤ that we share a concept, my movement initiates a prediction in your brain ... a uniquely human brand of magic. It is categorization as a cooperative act.

\* cardiovascular: 심혈관의 \*\* furrow: 찌푸리다 \*\*\* vibration: 진동

**Sentence Structure**

- You just have to agree in principle [that anger exists with certain functions].  
[ ]는 agree의 목적어 역할을 하는 명사절이다.

**Word Search** 주어진 문장에 들어갈 적절한 영어 단어를 본문에서 찾아 쓰시오. (필요시 형태를 바꿀 것)

1. The instructions e \_\_\_\_\_ stated that the deadline for submission was Friday.
2. The news spread quickly as people began to t \_\_\_\_\_ information through social media.
3. Some believe that musical talent is i \_\_\_\_\_, while others think it can be developed with practice.

## Exercise 2 주제 추론

다음 글의 주제로 가장 적절한 것은?

25007-0086

In order to better understand the dynamics of online interactions and the psychology behind group decision-making processes, consider a question that bears directly on group decisions in general: how people judge comments on websites. Lev Muchnik, a professor at the Hebrew University of Jerusalem, and his colleagues carried out an experiment on a website that displays diverse stories and allows people to post comments, which can in turn be voted up or down. The researchers automatically and artificially gave certain comments on stories an immediate upvote — the first vote that a comment would receive. You might well think that after hundreds or thousands of visitors and ratings, a single initial vote on a comment could not possibly matter. That is a sensible thought, but it is wrong. After seeing an initial upvote (and recall that it was entirely artificial), the next viewer became 32% more likely to give an upvote.

\* bear on: ~과 관련되다 \*\* upvote: 좋아요 투표

- ① effects of ratings and comments on self-esteem
- ② psychological reasons behind negative comments
- ③ common reactions to personal stories on websites
- ④ influence of initial votes on shaping online opinion
- ⑤ disadvantages of sharing opinions on social media

### Sentence Structure

- Lev Muchnik, a professor at the Hebrew University of Jerusalem, and his colleagues carried out an experiment on a website [that displays diverse stories and allows people to post comments, {which can in turn be voted up or down}].

[ ]는 a website를 수식하는 관계절이다. 그 안에 있는 { }는 comments를 추가적으로 설명하는 관계절이다.

**Word Search** 주어진 문장에 들어갈 적절한 영어 단어를 본문에서 찾아 쓰시오. (필요시 형태를 바꿀 것)

1. It's inappropriate to make rude or offensive **c**\_\_\_\_\_ online.
2. The university is known for its **d**\_\_\_\_\_ student population from all over the world.
3. She made a **s**\_\_\_\_\_ suggestion to address the problem without causing unnecessary conflict.

**Exercise 3** 제목 추론

다음 글의 제목으로 가장 적절한 것은?

25007-0087

We explain our world through stories. In our stories, we are both the storyteller and the principal character. Being able to tell our life story helps us to make sense of it. Perhaps we tell it to ourselves, quietly pondering. Perhaps we write it down, recognising in reading back something that we did not recognise at the time. But for most of us, chatting to a friend or reflecting with a confidant is the way we tell our stories. And as we tell them, we hear them anew. Telling helps us to notice and to interpret details, to become aware of the bigger picture or to discern aspects we previously overlooked or denied. Finding a listener who will give our story their full attention, who is prepared to become completely caught up in the tale, is an opportunity to meet ourselves, complete with our noble hopes and miserable failings, and to understand ourselves and the world around us in a truer, more helpful way.

\* ponder: 숙고하다 \*\* confidant: 절친한 친구

- ① Daydreaming: A Journey to Self-discovery
- ② Discovering Truths Through Others' Perspectives
- ③ Sharing Personal Stories, Building Stronger Relationships
- ④ The Art of Storytelling: A Necessary Skill to Master Success
- ⑤ Sharing Your Stories Opens a Door to Deeper Understanding of Yourself

**Sentence Structure**

- Telling helps us [{to notice} and {to interpret} details], [to become aware of the bigger picture] or [to discern aspects {we previously overlooked or denied}].

세 개의 [ ]가 콤마와 or로 연결되어 있으며 helps us에 이어진다. and로 연결된 첫 번째와 두 번째 { }에 details가 공통으로 이어진다. 세 번째 { }는 aspects를 수식하는 관계절이다.

**Word Search** 주어진 문장에 들어갈 적절한 영어 단어를 본문에서 찾아 쓰시오. (필요시 형태를 바꿀 것)

1. The company hired an expert to help i \_\_\_\_\_ the legal language in the contract.
2. It's easy to o \_\_\_\_\_ the importance of small gestures of kindness.
3. Being stuck at home with the flu made him feel m \_\_\_\_\_.

## Exercise 4 어법

(A), (B), (C)의 각 네모 안에서 어법에 맞는 표현으로 가장 적절한 것은?

25007-0088

In one study, products to the left of center in a horizontal display were chosen only 24 percent of the time. Why? Bruce D. Sanders, author of *Retailer's Edge*, notes that our eyes move to the right when the left hemisphere of the brain, where we do the math, (A) **get / gets** active. Therefore, when we think we've gotten a good deal, our happy left side of the brain dominates, and our eyes shift right. It's an explanation for (B) **what / why** right-of-center products are more frequently purchased than left-of-center products. This preference for right over left has nothing to do with conscious or rational decision making. When asked to rate four *identical* pairs of stockings, the pair (C) **positioned / was positioned** to the far right was chosen four to one over the pair on the far left. Even when experimenters suggested that the position of the stockings might have influenced their selection, participants' responses ranged from confused to dismissive.

- |   | (A)  |       | (B)  |       | (C)            |
|---|------|-------|------|-------|----------------|
| ① | get  | ..... | what | ..... | positioned     |
| ② | get  | ..... | why  | ..... | was positioned |
| ③ | gets | ..... | what | ..... | was positioned |
| ④ | gets | ..... | why  | ..... | was positioned |
| ⑤ | gets | ..... | why  | ..... | positioned     |

### Sentence Structure

- Even when experimenters suggested [that {the position of the stockings} might have influenced their selection], participants' responses ranged from confused to dismissive.  
[ ]는 suggested의 목적어 역할을 하는 명사절이고, 그 안에서 { }가 주어의 역할을 한다.

**Word Search** 주어진 문장에 들어갈 적절한 영어 단어를 본문에서 찾아 쓰시오. (필요시 형태를 바꿀 것)

1. In the brain, the left **h** \_\_\_\_\_ is typically associated with language and analytical thinking.
2. The large corporation continues to **d** \_\_\_\_\_ the global market.
3. She made a **c** \_\_\_\_\_ effort to improve her communication skills, attending public speaking classes.

**Exercise 5** 무관한 문장

다음 글에서 전체 흐름과 관계 없는 문장은?

25007-0089

With increased access to the internet across the world, consumers of healthcare (patients) are better educated. ① They are able to stay better informed about happenings around the world, timely news, and healthcare’s latest trends than at any previous time in history. ② Today’s consumers are demanding healthcare systems and experiences that accommodate their busy schedules, provide useful information that can be obtained quickly and easily, and that allow them to be involved in decision-making. ③ Even with the best of training, the highest of dedication, and the greatest of motivation, errors in medical procedure can still be made, but the number of errors can be diminished through the design of medical devices. ④ These consumers are different from those in the past because they also demand better access to care and better communication and a new level of participation with their healthcare providers. ⑤ Plans of treatment are often devised jointly and executed via creative methods.

**Sentence Structure**

- Today’s consumers are demanding healthcare systems and experiences [that {accommodate their busy schedules}, {provide useful information <that can be obtained quickly and easily>}], and [that allow them to be involved in decision-making].

두 개의 [ ]는 healthcare systems and experiences를 수식하는 관계절로 and로 연결되어 있다. 첫 번째 [ ] 안에서 두 개의 { }가 콤마로 연결되어 있고, 두 번째 { } 안의 < >는 useful information을 수식하는 관계절이다.

**Word Search**

주어진 문장에 들어갈 적절한 영어 단어를 본문에서 찾아 쓰시오. (필요시 형태를 바꿀 것)

1. Improving **a** \_\_\_\_\_ to healthcare is a priority for the government.
2. You can **o** \_\_\_\_\_ more information about the event from the official website.
3. **C** \_\_\_\_\_ are becoming more conscious of the environmental impact of their purchases.

## Exercise 6 글의 순서

주어진 글 다음에 이어질 글의 순서로 가장 적절한 것은?

25007-0090

While our gut may usually give us a good general sense of how the world works, it is frequently not precise. We need data to sharpen the picture.

(A) Just how significant is this effect? An optimistic read of the effectiveness of antidepressants would find that the most effective drugs decrease the incidence of depression by only about 20 percent. To judge from the search result numbers, a Chicago-to-Honolulu move would be at least twice as effective as medication for your winter blues.

(B) But you might not guess how big an impact this temperature difference can make. I looked for correlations between an area's Internet searches for depression and a wide range of factors, including economic conditions, education levels, and church attendance. Winter climate swamped all the rest. In winter months, warm climates, such as that of Honolulu, have 40 percent fewer depression searches than cold climates, such as that of Chicago.

(C) Consider, for example, the effects of weather on mood. You would probably guess that people are more likely to feel more gloomy on a 10-degree day than on a 70-degree day. Indeed, this is correct.

\* gut: 직감 \*\* swamp: 압도하다

① (A) - (C) - (B)

② (B) - (A) - (C)

③ (B) - (C) - (A)

④ (C) - (A) - (B)

⑤ (C) - (B) - (A)

### Sentence Structure

• But you might not guess [how big an impact this temperature difference can make].

[ ]는 guess의 목적어 역할을 하는 명사절이다. 간접의문문인 「how + 형용사 + a(n) + 명사 + 주어 + 동사」의 어순이 쓰이고 있다.

**Word Search** 주어진 문장에 들어갈 적절한 영어 단어를 본문에서 찾아 쓰시오. (필요시 형태를 바꿀 것)

- The architect sketched out a **p** \_\_\_\_\_ blueprint of the building's layout.
- She lives each day with an **o** \_\_\_\_\_ mindset, seeing challenges as opportunities.
- Access to education is a key **f** \_\_\_\_\_ in reducing inequality and poverty.

**Exercise 7** 어법

다음 글의 밑줄 친 부분 중, 어법상 틀린 것은?

25007-0091

Designers use diagrams, pictures, and simple illustrations to explain their work, ① whether it is how to turn the power on or off in a machine or how to use a DNA synthesizer or even a washing machine. Designers understand the need to test their efforts on the people ② for whom they are intended. Invariably, the tests reveal problems, places ③ where people do not understand, are confused, or, worse, could make serious errors in their use of the device under consideration: perhaps losing all of their work and, in the case of machinery or medical devices, perhaps leading to accidents or serious injuries. The reason for this early testing is ④ to find design flaws before the product is released, allowing the design to be corrected. In design, especially the set of procedures that goes under the general label *human-centered design*, multiple iterations of the design ⑤ is constructed and tested. Each new iteration — that is, each modification of the design — is guided by the results of tests.

\* iteration: 수정판, 새로운 버전

**Sentence Structure**

- The reason for this early testing is to find design flaws before the product is released, [**allowing the design to be corrected**].

[ ]는 결과적인 상황을 설명하는 분사구문이다. 「allow + 목적어 + to부정사」는 ‘~이 ...할 수 있게 하다’라는 의미이다.

**Word Search**

주어진 문장에 들어갈 적절한 영어 단어를 본문에서 찾아 쓰시오. (필요시 형태를 바꿀 것)

1. I didn't i \_\_\_\_\_ any disrespect.
2. He was momentarily c \_\_\_\_\_ by the foreign road signs.
3. The argument is full of fundamental f \_\_\_\_\_.

## Exercise 8 주제 추론

다음 글의 주제로 가장 적절한 것은?

25007-0092

It is interesting to note that all inquiries were once a part of philosophy, that great mother of the sciences (*mater scientiarum*), and philosophy embraced them all in an undifferentiated and amorphous fashion. However, as Western civilisation developed, various sciences began to pursue separate and independent courses. Astronomy and physics were among the first to break away, and were followed thereafter by chemistry, biology and geology. In the nineteenth century, two new sciences appeared: psychology (the science of human behaviour) and sociology (the science of human society). Thus, what had once been natural philosophy became the science of physics; what had been mental philosophy, or the philosophy of mind, became the science of psychology; and what had once been social philosophy, or the philosophy of history, became the science of sociology. To the ancient mother, philosophy, still belong several important kinds of enquiries — notably metaphysics, logic, ethics and aesthetics — but the sciences themselves are no longer studied as subdivisions of philosophy.

\* amorphous: 무정형(無定形)의 \*\* astronomy: 천문학 \*\*\* metaphysics: 형이상학

- ① reasons for people's avoidance of studying philosophy
- ② merits of balancing scientific and philosophical thinking
- ③ separation of the sciences from their philosophical roots
- ④ influence of scientific thinking on understanding philosophy
- ⑤ contribution of the sciences to forming a new branch of philosophy

### Sentence Structure

- Astronomy and physics [were among the first {to break away}], and [were followed thereafter by chemistry, biology and geology].

두 개의 [ ]가 and로 연결되어 주어 Astronomy and physics의 술어 역할을 하고, { }는 the first를 수식하는 to부정사구이다.

**Word Search** 주어진 문장에 들어갈 적절한 영어 단어를 본문에서 찾아 쓰시오. (필요시 형태를 바꿀 것)

1. Scientific i \_\_\_\_\_ seeks to uncover truths about the universe.
2. This idea has been widely e \_\_\_\_\_ by the scientific community.
3. The treatment was applied in an u \_\_\_\_\_ manner to all patients.

Exercise 9 제목 추론

다음 글의 제목으로 가장 적절한 것은?

25007-0093

Suppose that people’s aspirations rise as they get more money. When you live in a student dorm, you may aspire to have your own apartment, even if small. When you live in a small apartment, you may aspire to live in a bigger one. When you live in a bigger apartment, you may aspire to live in your own property. And so on: the more you have, the more you expect — and maybe the more you think you deserve. If so, the beneficial happiness effect of getting more money will be offset (at least partially) by the harmful effect on happiness of rising aspirations. Behavioural economists call this phenomenon the *aspiration treadmill*. The basic idea is ancient. The Stoic philosopher Seneca diagnosed the problem some 2,000 years ago. He wrote: ‘Excessive prosperity does indeed create greed in men, and never are desires so well controlled that they vanish once satisfied.’

\* offset: 상쇄하다

- ① Greed: The Cause of Internal Divisions Within Society
- ② Moral Dilemmas in the Pursuit of Accumulating Wealth
- ③ Why Does Achieving Happiness Matter in Modern Society?
- ④ For Financial Freedom, Shift Your Focus from How to When
- ⑤ Wanting More and More: How It Can Harm Your Happiness

Sentence Structure

- He wrote: ‘Excessive prosperity **does** indeed create greed in men, and [**never are desires** so well controlled that **they** vanish {once satisfied}].’

조동사 does는 create를 강조하는 역할로 사용되었고, [ ]에서는 부정어 never가 앞에 위치하여 주어 desires와 동사 are가 도치되었다. they는 desires를 가리키고, { }에서는 접속사 once 뒤에 they are가 생략된 것으로 볼 수 있다.

Word Search 주어진 문장에 들어갈 적절한 영어 단어를 본문에서 찾아 쓰시오. (필요시 형태를 바꿀 것)

- 1. He said he never a \_\_\_\_\_ to become famous.
- 2. The price of p \_\_\_\_\_ has risen enormously.
- 3. I felt I d \_\_\_\_\_ better than that.

## Exercise 10 어법

다음 글의 밑줄 친 부분 중, 어법상 틀린 것은?

25007-0094

Humanity has entered a new era. We are now living in a world that is increasingly wired by billions of predictive algorithms, a world ① in which almost everything can be predicted and risk and uncertainty appear to be diminishing in almost all areas of life. We are living ② longer, thanks to advances in health care and precision medicine. We have a greater mastery of the physical world that allows us to dream of, and build, new technologies that allow us to explore other planets and ③ visualizes billions of galaxies. We can model markets, disease, and traffic with increasingly greater precision, and we're getting very close to handing over the keys to the car so it can drive ④ itself. Even more striking, our tools may be revealing the genesis of some elusive and stubborn complexities of human behavior, and algorithms are even being used to ⑤ alter people's behavior. Predictive algorithms have changed the world, and all the worlds to come, and there is no going back.

\* genesis: 기원 \*\* elusive: 이해하기 어려운 \*\*\* stubborn: 다루기 힘든

### Sentence Structure

- We are now living in a world [that is increasingly wired by billions of predictive algorithms], ~.  
[ ]는 a world를 수식하는 관계절이다.

**Word Search** 주어진 문장에 들어갈 적절한 영어 단어를 본문에서 찾아 쓰시오. (필요시 형태를 바꿀 것)

1. Using p modeling, weather experts can better forecast severe weather events.
2. The company's profits began to d after the economic downturn.
3. The doctor performed the complex brain surgery with p.

**Exercise 11** 무관한 문장

다음 글에서 전체 흐름과 관계 없는 문장은?

25007-0095

It is worth noting that the progress in man's understanding about the physical aspects of his environment occurred much earlier in comparison to the social aspects. ① The main reason for this discrepancy in the development of man's understanding of the two distinct environments — the physical and the social — probably lies in the greater observability and control of physical phenomena, as well as in the impersonal approach that they afford. ② Physical phenomena are usually more concrete than social phenomena and hence are more observable. ③ Both the physical environment and social environment play crucial roles in shaping individual well-being and overall community health. ④ Samuel Koenig states that in his attempt to observe physical phenomena man was able quite early to develop a measure of detachment, but he found it very difficult to do so regarding social phenomena. ⑤ In the latter case he found himself too close to the object of investigation, too involved in it, to achieve the objectivity which is indispensable to all science.

\* discrepancy: 차이 \*\* indispensable: 필수적인

**Sentence Structure**

- It is **worth noting** [that {the progress in man's understanding about the physical aspects of his environment} occurred much earlier in comparison to the social aspects].

'be worth + -ing'은 '~할 만한 가치가 있다'라는 표현이다. { }는 [ ] 안에서 주어로 쓰였다.

**Word Search** 주어진 문장에 들어갈 적절한 영어 단어를 본문에서 찾아 쓰시오. (필요시 형태를 바꿀 것)

1. The project showed slow but steady **p**\_\_\_\_\_.
2. They made a **c**\_\_\_\_\_ of different countries' eating habits.
3. This was one **a**\_\_\_\_\_ of her character he hadn't seen before.

## Exercise 12 글의 순서

주어진 글 다음에 이어질 글의 순서로 가장 적절한 것은?

25007-0096

When computers process in time, we typically want them to also work in real time. For example, if you set up a microphone with a reverb effect for a performance, you would like it to work both in time and in real time.

- (A) If the computer can process a three-minute sound file in seven seconds, it is unnecessary to wait three minutes to finish its processing. You may also happen to have a computationally heavy reverb model that runs “slower than real time.” For a producer working in a studio, it is not crucial whether a process runs in real time.
- (B) However, if you just want to add reverb to a prerecorded song, it does not matter when or how fast it happens. You may probably prefer that the computer does the processing “faster than real time.”
- (C) For a performer on stage, however, there is no other option than running in real-time mode. The concert is happening in the “now,” hence the tools used need to run both in time and in real time.

\* reverb: (음향 장치로 소리의 울림을 줄게 하기 위한) 에코

- ① (A) - (C) - (B)                      ② (B) - (A) - (C)                      ③ (B) - (C) - (A)
- ④ (C) - (A) - (B)                      ⑤ (C) - (B) - (A)

### Sentence Structure

- [If the computer can process a three-minute sound file in seven seconds], **it** is unnecessary [to wait three minutes to finish its processing].

첫 번째 [ ]는 조건을 나타내는 부사절이다. **it**은 형식상의 주어이고, 두 번째 [ ]가 내용상의 주어에 해당하는 to부정사구이다.

**Word Search** 주어진 문장에 들어갈 적절한 영어 단어를 본문에서 찾아 쓰시오. (필요시 형태를 바꿀 것)

1. This evening's **p** \_\_\_\_\_ will start at 7 o'clock.
2. The information gathered by the telescopes will be **p** \_\_\_\_\_ by computers.
3. Some people like chocolate ice cream, but I **p** \_\_\_\_\_ vanilla.

**Exercise 1** 어휘

다음 글의 밑줄 친 부분 중, 문맥상 낱말의 쓰임이 적절하지 않은 것은?

25007-0097

At its most fundamental, relative brightness identifies the visual contrasts by which we live. Without contrast, the essentials of vision fail to operate; the brain will not identify edges and forms nor perceive depth or distance. The ① fewer the contrasts, the less able we are to identify details, and the less able we are to navigate the environment. Ideal visual conditions are those where contrasts of relative brightness are most ② easily identified, where the light source is strong and casts sharply defined shadows. It follows that ideal visual conditions are most likely to generate positive feeling-responses. At the opposite end of the safe/dangerous spectrum, the most ③ secure visual conditions are those where the contrasts given by a range of relative brightness no longer exist. Complete darkness (as in an underground cave) and complete brightness (as in a blizzard whiteout) are equally filled with danger. In these ④ extreme conditions of brightness, details are erased, and navigation becomes hazardous. Emotion-feelings aroused by conditions such as these are most likely to be ⑤ negative.

\* blizzard: 눈보라    \*\* whiteout: 화이트아웃(천지가 모두 백색이 되어 방향 감각을 잃어버리는 상태)

**Sentence Structure**

- Without contrast, the essentials of vision fail to operate; the brain [will **not** identify edges and forms **nor** perceive depth or distance].

[ ]는 절의 술부로 '~이 아니고 ...도 아닌'이라는 의미의 「not ~ nor ...」이 사용되었다.

**Word Search**

주어진 문장에 들어갈 적절한 영어 단어를 본문에서 찾아 쓰시오. (필요시 형태를 바꿀 것)

1. The remote control allows you to o \_\_\_\_\_ all the features of your TV.
2. Scientists work to i \_\_\_\_\_ new species in remote regions of the rainforest.
3. Refugees demanded c \_\_\_\_\_ freedom to do whatever they wanted.

## Exercise 2 문장 삽입

글의 흐름으로 보아, 주어진 문장이 들어가기에 가장 적절한 곳은?

25007-0098

Such a discovery may have enormous commercial implications, perhaps leading to the invention of a device that filters out the harmful effect of the waves.

The most important inherent limitation on patentable subject matter revolves around the sometimes blurred distinction between an *invention* and a *discovery*. ( ① ) Laws of nature or scientific principles that a researcher may ‘find’ are not patentable. ( ② ) For example, imagine that a scientist discovers that a certain previously unknown form of magnetic wave strikes the earth’s atmosphere from deep space, and that this kind of wave has an adverse effect on the transmission of data between the earth and communications satellites. ( ③ ) The inventor of the filtering device may be entitled to a patent. ( ④ ) The discoverer of the magnetic wave cannot patent his or her discovery. ( ⑤ ) Today, the distinction between discovery and invention is of increasing importance in the fields of genetic engineering and biotechnology.

\* blurred: 모호한

### Sentence Structure

- Such a discovery may have enormous commercial implications, [perhaps leading to the invention of a device {that filters out the harmful effect of the waves}].

[ ]는 주절의 내용에 부가적으로 이어지는 결과를 나타내는 분사구문이고, 그 안의 { }는 a device를 수식하는 관계절이다.

**Word Search** 주어진 문장에 들어갈 적절한 영어 단어를 본문에서 찾아 쓰시오. (필요시 형태를 바꿀 것)

1. The artist believed that creativity was **i**\_\_\_\_\_ in all individuals.
2. The **p**\_\_\_\_\_ of equality is fundamental to the legal system.
3. Every citizen is **e**\_\_\_\_\_ to basic human rights, regardless of their social status.

**Exercise 3** 요약문 완성

다음 글의 내용을 한 문장으로 요약하고자 한다. 빈칸 (A), (B)에 들어갈 말로 가장 적절한 것은?

25007-0099

“Farm animals, lab animals, sport horses...”: our language when we refer to some animals often focuses on their exploitation and on the benefits humans get from them, for example, animals as a source of food, used in biomedical research or for recreational activities. When we refer to some animals as “pets,” are we implying their use for any purpose? A pet can be defined, in a neutral manner, as an animal that lives with humans. Another largely used term is “companion animal,” which, again, implies that we keep them in our home with the final aim of getting companionship. Some may argue that a fish in the fish tank is not really anyone’s companion. However, this term well adapts to domestic species, such as dogs and cats, which we treat kindly, consider as members of the family and our “best friends,” and with whom we share our time and financial resources. Differently from other species, companion animals thus appear to represent an emotional — rather than an economical — resource, providing humans with support, comfort and companionship.



When it comes to animal discourse, our language typically emphasizes the \_\_\_ (A) \_\_\_ of some animals, whereas the terms for those kept in homes suggest their \_\_\_ (B) \_\_\_ significance.

- |                |       |              |  |                 |       |             |
|----------------|-------|--------------|--|-----------------|-------|-------------|
| (A)            |       | (B)          |  | (A)             |       | (B)         |
| ① behavior     | ..... | cognitive    |  | ② profitability | ..... | utilitarian |
| ③ emotion      | ..... | recreational |  | ④ utility       | ..... | relational  |
| ⑤ intelligence | ..... | cultural     |  |                 |       |             |

**Sentence Structure**

- Another largely used term is “companion animal,” [which, again, implies {that we keep them in our home with the final aim of getting companionship}].  
 [ ]는 “companion animal”을 부수적으로 설명하는 관계절이고, 그 안의 { }는 implies의 목적어 역할을 하는 명사절이다.

**Word Search** 주어진 문장에 들어갈 적절한 영어 단어를 본문에서 찾아 쓰시오. (필요시 형태를 바꿀 것)

1. Regular exercise offers a multitude of **b** \_\_\_\_\_, including better mood regulation.
2. Scientists conduct **r** \_\_\_\_\_ to advance knowledge and solve problems.
3. Pets provide valuable **c** \_\_\_\_\_ to their owners.

## Exercise 4 어휘

(A), (B), (C)의 각 네모 안에서 문맥에 맞는 낱말로 가장 적절한 것은?

25007-0100

Whilst some stakeholders may try to protect the integrity of arts and cultural festivals from their reconfiguration as urban policy tools, we should recognise that policy-oriented festivals can still have very positive social and cultural effects. And we cannot (A) ignore / acknowledge the fact that some festivals were established to strategically assist urban areas. In other words, they have always been strategic interventions rather than artistic, social or cultural phenomena. Film festivals are a good example: many of these events were established for (B) economic / recreational reasons: for example, the Cannes Film Festival was launched to prolong the tourist season. The Brighton Festival was created for similar reasons. The re-establishment of the Venice Carnival in 1979, following a long break, was also a(n) (C) deliberate / accidental attempt to address some of the issues the city was facing at that time, including the lack of provision for young people. These festivities have not been appropriated as urban policy tools: they have always been staged with wider objectives in mind.

\* stakeholder: 이해 당사자 \*\* reconfiguration: 재구성 \*\*\* appropriate: 전용[도용]하다, 사용(私用)하다

- | (A)           | (B)                | (C)              |
|---------------|--------------------|------------------|
| ① ignore      | ..... economic     | ..... deliberate |
| ② ignore      | ..... recreational | ..... deliberate |
| ③ ignore      | ..... economic     | ..... accidental |
| ④ acknowledge | ..... recreational | ..... accidental |
| ⑤ acknowledge | ..... economic     | ..... accidental |

### Sentence Structure

- [Whilst some stakeholders may try to protect the integrity of arts and cultural festivals from their reconfiguration as urban policy tools], we should recognise [that policy-oriented festivals can still have very positive social and cultural effects].

첫 번째 [ ]는 Whilst가 이끄는 양보의 부사절이고, 두 번째 [ ]는 recognise의 목적어 역할을 하는 명사절이다.

**Word Search** 주어진 문장에 들어갈 적절한 영어 단어를 본문에서 찾아 쓰시오. (필요시 형태를 바꿀 것)

1. The p \_\_\_\_\_ requires all employees to undergo annual training on data privacy.
2. P \_\_\_\_\_ thinking can lead to improved mental health and overall well-being.
3. Scientists study various weather p \_\_\_\_\_, such as tornadoes and hurricanes.

## Exercise 5~6

## 1지문 2문항

[5~6] 다음 글을 읽고, 물음에 답하시오.

You may have heard “a calorie is a calorie is a calorie.” While it is true that each calorie yields the same amount of energy, foods can be metabolized and used differently, some more efficiently than others. For example, carbohydrates, protein and fat, the macronutrients that provide calories, can each have (a) different effects on the hormones and brain centers that control hunger and eating behavior. Macronutrients have (b) standard amounts of calories. One gram of protein has 4 calories. One gram of carbohydrates has 4 calories. One gram of fat has 9 calories.

However, the source is (c) irrelevant. There are many compounds in foods, besides the macronutrients, that can influence your body’s process and response mechanisms. Even though each gram of carbohydrates provides four calories per gram, not all carbohydrates are created (d) equal. For example, white bread has been refined and stripped of its fiber. Because of this, white bread may cause a spike in blood sugar, whereas whole grain bread is less processed and has its fiber intact. This (e) allows for a slower release of sugar into the blood, meaning that while white and whole grain bread may have the same total *amount* of carbohydrates, the way they *affect* your blood sugar is very different.

\* metabolize: 대사시키다 \*\* macronutrient: 다량 영양소(생물체가 다량으로 필요로 하는 영양소) \*\*\* intact: 온전한

## 5 윗글의 제목으로 가장 적절한 것은?

25007-0101

- ① Do Your Foods Contain Enough Calories?
- ② Hidden Facts: Sugar Intake Makes You Healthy
- ③ Do Not Look at the Calorie Label, Just Enjoy Your Food
- ④ Beyond Calories: Unveiling the Impact of Nutrient Sources
- ⑤ Secret to Cooking: Different Tastes Depending on the Recipe

## 6 밑줄 친 (a)~(e) 중에서 문맥상 낱말의 쓰임이 적절하지 않은 것은?

25007-0102

- ① (a)
- ② (b)
- ③ (c)
- ④ (d)
- ⑤ (e)

### Sentence Structure

- [While **it** is true {that each calorie yields the same amount of energy}], foods can be metabolized and used differently, some more efficiently than others.

[ ]는 While이 이끄는 양보의 부사절인데, 그 안에서 it은 형식상의 주어, that이 이끄는 명사절인 { }가 내용상의 주어이다.

### Word Search 주어진 문장에 들어갈 적절한 영어 단어를 본문에서 찾아 쓰시오. (필요시 형태를 바꿀 것)

1. The decisions we take now may **i**\_\_\_\_\_ the course of events in the future.
2. The chef continued to **r**\_\_\_\_\_ the recipe to achieve the perfect flavor balance.
3. The company announced the **r**\_\_\_\_\_ of its latest product, generating excitement among consumers.

**Exercise 7** 어휘

다음 글의 밑줄 친 부분 중, 문맥상 낱말의 쓰임이 적절하지 않은 것은?

25007-0103

Sentiment is very close to emotion in meaning, but when social psychologists use the term sentiment, they emphasize the social aspect of emotion. Early social psychologists used sentiment to refer to the components of human responses that ① separate them from analogous responses that animals would have. For example, Cooley contrasts love and lust. Although lust is instinctive, we ② learn what love is through social interaction. In other words, sentiment relies not just on the responses of the individual to the stimulus but also on how other human beings understand that stimulus. In later years, as social psychologists have come to increasingly accept that social elements are a key piece of emotions, the idea of sentiment has become ③ more distinguishable from that of emotion. In contemporary work, social psychologists often use the term sentiment to distinguish ④ immediate emotional responses from longer-term emotional states such as love, grief, and jealousy. These sentiments can endure for days, weeks, and even years after the ⑤ initial event that triggered them.

\* analogous: 유사한 \*\* lust: 욕망, 욕정

**Sentence Structure**

- In other words, sentiment relies **not just** [on the responses of the individual to the stimulus] **but also** [on how other human beings understand that stimulus].

두 개의 [ ]가 ‘~뿐만 아니라 ...도’라는 의미의 「not just ~ but also ...」구문으로 연결되어 relies에 이어진다.

**Word Search**

주어진 문장에 들어갈 적절한 영어 단어를 본문에서 찾아 쓰시오. (필요시 형태를 바꿀 것)

1. The study intends to c \_\_\_\_\_ urban and rural living conditions.
2. Each i \_\_\_\_\_ reacts differently to stress based on their unique circumstances.
3. The c \_\_\_\_\_ art exhibit featured works by artists from around the world.

## Exercise 8 문장 삽입

글의 흐름으로 보아, 주어진 문장이 들어가기에 가장 적절한 곳은?

25007-0104

On the other hand, if the organism dies a natural death, although the soft parts of the body will almost certainly rot away, neither shell is likely to be damaged.

To become a fossil is a long and involved process, and is an unlikely outcome for the vast majority of individuals. The most obvious requirement for an organism to end up as a fossil is that it must become entombed within rock, usually by burial. ( ① ) There are many chances that can prevent this happening. ( ② ) If a mollusc with two shells has the misfortune to be killed by a predator, then the soft parts will be eaten. ( ③ ) The predator will probably have to break at least one of the shells to gain access to the flesh, so it is unlikely that both shells will survive intact. ( ④ ) Even if they do, the two shells may become separated. ( ⑤ ) The shells are held together at the hinge by fibrous tissues, which are among the last to rot, so there is a reasonable chance that the two shells will remain held together until they become buried.

\* mollusc: 연체동물 \*\* intact: 온전한 \*\*\* hinge: (겹질의) 이음매

### Sentence Structure

- The shells are held together at the hinge by fibrous tissues, [which are among the last to rot], so there is a reasonable chance [that the two shells will remain held together {until they become buried}].

첫 번째 [ ]는 fibrous tissues를 부수적으로 설명하는 관계절이며, 두 번째 [ ]는 a reasonable chance와 동격 관계를 이루는 명사절이고, { }는 시간의 부사절이다.

**Word Search** 주어진 문장에 들어갈 적절한 영어 단어를 본문에서 찾아 쓰시오. (필요시 형태를 바꿀 것)

1. It is u \_\_\_\_\_ that the delicate flower will survive the harsh winter without protection.
2. The o \_\_\_\_\_ of the experiment will determine the next steps in the research process.
3. She had a r \_\_\_\_\_ amount of time to complete the project before the deadline.

**Exercise 9** 요약문 완성

다음 글의 내용을 한 문장으로 요약하고자 한다. 빈칸 (A), (B)에 들어갈 말로 가장 적절한 것은?

25007-0105

Sometimes, a monkey grooms another monkey and gets nothing in return. Sometimes an ape courts a mate and gets completely ignored. Cortisol prompts a mammal to try something different, but after a few disappointments it can be hard for the mammal to predict where to invest its energy. This is why we often fall back on the neural superhighways we myelinated in youth. Your electricity flows effortlessly down the pathways built by behaviors that were reliably rewarded in your past. Maybe it was scoring a touchdown, or joining friends to watch your favorite quarterback score. Of course, carrying a ball across a line does not meet real survival needs, but dopamine surges when you expect a social reward. Each brain predicts social rewards from its own life experience. Maybe you lived in a world where social rewards went to someone who cooked a big meal or solved a big equation or found a bar open after hours. There are limitless ways to get social rewards, but the ones we observe and enjoy in youth build expectations that last.

\* court: 구애하다    \*\* cortisol: 코르티솔(부신 피질에서 생기는 스테로이드 호르몬의 일종)  
\*\*\* myelinate: 미엘린(신경 세포를 싸고 있는 보호막)을 형성하다



Just as repeated social disappointments can lead individuals to return to        (A) behaviors reinforced in their youth, the brain relies on past experiences and neural pathways to predict and seek out        (B) experiences.

- |              |       |             |  |               |       |             |
|--------------|-------|-------------|--|---------------|-------|-------------|
| (A)          |       | (B)         |  | (A)           |       | (B)         |
| ① impulsive  | ..... | rewarding   |  | ② familiar    | ..... | rewarding   |
| ③ innovative | ..... | exhausting  |  | ④ destructive | ..... | frustrating |
| ⑤ habitual   | ..... | frustrating |  |               |       |             |

**Sentence Structure**

- Your electricity flows effortlessly down the pathways [built by behaviors {that were reliably rewarded in your past}].  
[ ]는 the pathways를 수식하는 분사구이고, 그 안의 { }는 behaviors를 수식하는 관계절이다.

**Word Search**

주어진 문장에 들어갈 적절한 영어 단어를 본문에서 찾아 쓰시오. (필요시 형태를 바꿀 것)

1. The team's loss in the final game was a major **d**\_\_\_\_\_ to their fans.
2. The machine **r**\_\_\_\_\_ produces high-quality results.
3. Access to clean water is crucial for the **s**\_\_\_\_\_ of all living organisms.

## Exercise 10 어휘

다음 글의 밑줄 친 부분 중, 문맥상 낱말의 쓰임이 적절하지 않은 것은?

25007-0106

To determine whether a person is lying, we tend to rely heavily on intuition. Unless we catch a lie on ① factual grounds, the only indicators of a person's dishonesty are tone of voice, body language, and facial expressions — signs that may be too subtle for us to consciously recognize but that can still evoke a strong gut feeling. The problem is that while we can practice our skills at evaluating others' truthfulness in social interactions, ② without clear feedback on whether our judgments are correct we don't know if we're erring on the side of gullibility or of distrustfulness. This means we're ③ able to improve over time. Though many people believe they're quite good at distinguishing truths from lies, almost no one in the general population performs with ④ higher than chance accuracy. On average, even police officers, lawyers, judges, psychiatrists, and members of other groups that encounter more frequent and serious lies than ⑤ ordinary people perform no better.

\* gut feeling: 직감 \*\* err on the side of: 지나치다 싶을 정도로 ~하다 \*\*\* gullibility: 쉽게 속음

### Sentence Structure

- [Unless we catch a lie on factual grounds], the only indicators of a person's dishonesty are tone of voice, body language, and facial expressions — signs [that may be too subtle for us to consciously recognize] but [that can still evoke a strong gut feeling].

첫 번째 [ ]는 조건을 나타내는 부사절이며, 두 번째와 세 번째 [ ]는 but으로 대등하게 연결되어 signs를 수식하는 관계절이다.

**Word Search** 주어진 문장에 들어갈 적절한 영어 단어를 본문에서 찾아 쓰시오. (필요시 형태를 바꿀 것)

1. It can be difficult to d \_\_\_\_\_ the cause of a problem without thorough investigation.
2. There was a s \_\_\_\_\_ change in her tone that indicated she was upset.
3. It can be hard to d \_\_\_\_\_ between genuine and fake products.

## Exercise 11~12 1지문 2문항

[11~12] 다음 글을 읽고, 물음에 답하십시오.

In ancient times, not each and every kind of suffering warranted pity. No one was supposed to feel pity for captured, tortured, and killed enemies. Neither slaves nor Christian martyrs deserved pity. Later on, religious communities that preached the gospel of brotherly love and love of neighbor found no difficulty in (a) denying it to those who did not belong and believe. This attitude only started to change during the 18th century. Playwrights reviving the Aristotelian concept of catharsis discovered pity as the most natural and most moral human faculty that should be (b) cultivated by theater, literature, and music. Philosophers who sought a moral foundation for modern civil society (c) praised pity and sympathy as counter-forces of self-love and egoism. Novelists were (d) eager to devise plots and stories that would elicit the readers' pity, inspiring them to become sensitive and sensible citizens. At the same time, hundreds of thousands of European and North American men and women campaigned for the ending of slavery and the liberation of slaves. Fueled by an “imagined empathy” and using a language of love for those “brothers” and “sisters” whose freedom and human dignity were (e) respected, they engaged in an unprecedented — and ultimately successful — struggle against the slave trade and the institution of slavery.

\* martyr: 순교자 \*\* gospel: 복음, 기독교의 교의 \*\*\* egoism: 이기심

**11** 윗글의 제목으로 가장 적절한 것은?

25007-0107

- ① Tips for Nurturing Empathy and Kindness
- ② Pity's Paradox: Can Feeling Sorry Lead to Real Help?
- ③ Why Compassion Matters More Than Ever Nowadays
- ④ The Evolution of Pity: From Ancient Attitudes to Modern Ones
- ⑤ A Double-Edged Sword: Examining the Power and Limits of Pity

**12** 밑줄 친 (a)~(e) 중에서 문맥상 낱말의 쓰임이 적절하지 않은 것은?

25007-0108

- ① (a)
- ② (b)
- ③ (c)
- ④ (d)
- ⑤ (e)

**Sentence Structure**

- Playwrights [reviving the Aristotelian concept of catharsis] discovered pity as the most natural and most moral human faculty [that should be cultivated by theater, literature, and music].

첫 번째 [ ]는 Playwrights를 수식하는 분사구이며, 두 번째 [ ]는 the most natural and most moral human faculty를 수식하는 관계절이다.

**Word Search** 주어진 문장에 들어갈 적절한 영어 단어를 본문에서 찾아 쓰시오. (필요시 형태를 바꿀 것)

1. It is important to feel **p**\_\_\_\_\_ for those who are suffering and to offer help whenever possible.
2. Even if your **r**\_\_\_\_\_ faith is strong, it's normal to feel doubt.
3. The company's positive **a**\_\_\_\_\_ towards innovation has led to many successful products.

**Exercise 1** 어휘

다음 글의 밑줄 친 부분 중, 문맥상 낱말의 쓰임이 적절하지 않은 것은?

25007-0109

One of the striking features of many invasions is a massive, early population outbreak that makes the alien form conspicuous and often highly destructive. In some species this outbreak may occur ① immediately after initial introduction; in others it occurs only after a delay of years, decades, or even a century. Following the outbreak, however, the population of the alien, as well as its ecological impact, may ② decline substantially. In many cases, native species also make ecological and evolutionary adjustments that shield them from the impacts of aliens. In addition, the population outbreak of the alien ③ creates massive ecological and evolutionary opportunities for exploitation by members of the native community. Ecological responses may be rapid, as members of the native community ④ learn to exploit the new community member as a food source and to avoid its direct detrimental influences. Later, evolutionary adjustments ⑤ reduce the ability of members of the native community to use the alien as a resource or to avoid the negative impacts of the alien.

\* conspicuous: 눈에 띄는 \*\* exploitation: 이용 \*\*\* detrimental: 해로운

**Sentence Structure**

- In many cases, native species also make ecological and evolutionary adjustments [that shield **them** from the impacts of aliens].

[ ]는 ecological and evolutionary adjustments를 수식하는 관계절이고, 그 안의 them은 native species를 가리킨다.

**Word Search**

주어진 문장에 들어갈 적절한 영어 단어를 본문에서 찾아 쓰시오. (필요시 형태를 바꿀 것)

1. The sudden i \_\_\_\_\_ of the village by the enemies surprised everyone.
2. The city hosted a m \_\_\_\_\_ festival that attracted thousands of people from all over the country.
3. The trees can s \_\_\_\_\_ the animals from harsh winds and heavy rain.

## Exercise 2 문장 삽입

글의 흐름으로 보아, 주어진 문장이 들어가기에 가장 적절한 곳은?

25007-0110

In contrast, marketing through sport happens when a non-sport product is marketed through an association to sport.

It is useful to note that there are two angles to sport marketing. The first is that sport products and services can be marketed directly to the consumer. ( ① ) The second is that other, non-sport products and services can be marketed through the use of sport. ( ② ) In other words, sport marketing involves the marketing of sport and marketing through sport. ( ③ ) For example, the marketing of sport products and services directly to sport consumers could include sporting equipment, professional competitions, sport events and local clubs. ( ④ ) Other simple examples include team advertising, designing a publicity stunt to promote an athlete, selling season tickets, and developing licensed clothing for sale. ( ⑤ ) Some examples could include a professional athlete endorsing a breakfast cereal, a corporation sponsoring a sport event, or even a beer company arranging to have exclusive rights to provide beer at a sport venue or event.

\* publicity stunt: 떠들썩한 선전 \*\* endorse: 홍보하다 \*\*\* venue: 행사장

### Sentence Structure

- Some examples could include [{a professional athlete endorsing a breakfast cereal}, {a corporation sponsoring a sport event}], or even {a beer company arranging to have exclusive rights to provide beer at a sport venue or event}].

[ ] 안에서 세 개의 { }가 콤마와 or로 대등하게 연결되어 include의 목적어를 이룬다. 세 개의 { }에서 a professional athlete, a corporation, a beer company는 각각 이어지는 동명사의 의미상의 주어이다.

**Word Search** 주어진 문장에 들어갈 적절한 영어 단어를 본문에서 찾아 쓰시오. (필요시 형태를 바꿀 것)

- The logo's design has a strong **a** \_\_\_\_\_ to the company's brand identity.
- This cycling program provides necessary **e** \_\_\_\_\_ such as bikes and helmets.
- The **a** \_\_\_\_\_ trains every morning to prepare for the big race.

**Exercise 3** 요약문 완성

다음 글의 내용을 한 문장으로 요약하고자 한다. 빈칸 (A), (B)에 들어갈 말로 가장 적절한 것은?

25007-0111

Determining the probability that a particular event will occur in a particular location within a particular time span is an essential goal of hazard evaluation. For many large rivers we have sufficient records of flow to develop probability models that can reasonably predict the average number of floods of a given magnitude that will occur in a given time period. Likewise, droughts may be assigned a probability on the basis of past occurrence of rainfall in the region. However, these probabilities are similar to the chances of throwing a particular number on a die or drawing an inside straight in poker; the element of chance is always present. For example, the 10-year flood may occur on the average of every 10 years, but it is possible for several floods of this magnitude to occur in any one year, just as it is possible to throw two straight sixes with a die.

\* magnitude: 규모 \*\* die: 주사위

\*\*\* inside straight: 인사이드 스트레이트(4장의 숫자가 있을 때 5개의 연속된 숫자를 만들기 위해 특정 카드 한 장이 필요한 패)



Hazard evaluation involves estimating the     (A)     of events like floods or droughts in a specific time and space based on records, while always carrying an element of     (B)     with it.

- |              |       |                 |  |              |       |            |
|--------------|-------|-----------------|--|--------------|-------|------------|
| (A)          |       | (B)             |  | (A)          |       | (B)        |
| ① likelihood | ..... | randomness      |  | ② likelihood | ..... | locality   |
| ③ intensity  | ..... | locality        |  | ④ duration   | ..... | randomness |
| ⑤ duration   | ..... | standardization |  |              |       |            |

**Sentence Structure**

- [Determining the probability {that a particular event will occur in a particular location within a particular time span}] is an essential goal of hazard evaluation.

[ ]는 문장의 주어 역할을 하는 동명사구이고, 그 안의 { }는 the probability의 구체적 내용을 설명하는 동격절이다.

**Word Search** 주어진 문장에 들어갈 적절한 영어 단어를 본문에서 찾아 쓰시오. (필요시 형태를 바꿀 것)

1. Simply put, **p** \_\_\_\_\_ is the possibility of an event happening expressed in numbers.
2. The family **r** \_\_\_\_\_ discussed the vacation plans, considering everyone's preferences.
3. Team collaboration is an important **e** \_\_\_\_\_ of the job.

## Exercise 4 어휘

(A), (B), (C)의 각 네모 안에서 문맥에 맞는 낱말로 가장 적절한 것은?

25007-0112

Among the first studies to suggest the (A) use / avoidance of specifically a visual in contrast to verbal or phonologically based temporary memory for verbal stimuli were those conducted by psychologist Posner and his colleagues, who developed a visual letter-matching task in which pairs of letters were shown in their upper case (e.g., AB) or lower case (e.g., aa) versions or a mixture of both (e.g., Bb). The subjects' task was to respond on the basis of whether the letters in the pair had the same name (e.g., Aa) or had different names (e.g., Ab). When the letters were both in the same letter case and were physically identical (e.g., AA), subjects responded much more (B) quickly / slowly than if the upper and lower case versions were different. The advantage for physically identical letters remained when letters in each pair were shown one after another with interletter delays of up to 2 seconds. This suggested that subjects were (C) passing / relying on the visual code for the letters during the delay, after which a name code was being used for the decision.

\* phonologically: 음운론적으로

- |   | (A)       |       | (B)     |       | (C)     |
|---|-----------|-------|---------|-------|---------|
| ① | use       | ..... | quickly | ..... | passing |
| ② | use       | ..... | slowly  | ..... | relying |
| ③ | use       | ..... | quickly | ..... | relying |
| ④ | avoidance | ..... | slowly  | ..... | passing |
| ⑤ | avoidance | ..... | quickly | ..... | relying |

### Sentence Structure

- The subjects' task was [to respond on the basis of {whether the letters in the pair had the same name (e.g., Aa) or had different names (e.g., Ab)}].  
[ ]는 주격 보어 역할을 하는 to부정사구이고, 그 안의 { }는 전치사 of의 목적어 역할을 하는 명사절이다.

**Word Search** 주어진 문장에 들어갈 적절한 영어 단어를 본문에서 찾아 쓰시오. (필요시 형태를 바꿀 것)

- Plants respond to environmental **s** \_\_\_\_\_ such as light and temperature changes.
- Because her handwriting was nearly **i** \_\_\_\_\_ to her mother's, it was hard to distinguish between the two.
- Being fluent in multiple languages can be a considerable **a** \_\_\_\_\_ when traveling.

## Exercise 5~6

## 1지문 2문항

[5~6] 다음 글을 읽고, 물음에 답하시오.

As more and more brands and organizations started working with influences, the return on influencer (yes, pun intended) has decreased. People realize that their heroes are being (a) paid to promote brands on social media. The amount celebrities can get for promoting brands goes up to half a million dollars for a mention in one single Instagram post. So, in the past few years, brands have slowly extended their influencer marketing strategies to so-called micro-influencers. These are people with 10,000 to 50,000 followers who are seen as experts or heroes to a smaller group of people. Because of the (b) size of their following, their messages on social media are perceived to be authentic and therefore more trustworthy. As this strategy is also gaining (too much) popularity, several experts have predicted that the 2020s will be the era of the nano influences. These are people with 1,000 – 10,000 followers and who are just like your own most popular friends and family members; their lack of any real fame will be a sign of their (c) untrustworthiness.

The expectation is that this nano category will also eventually (d) lose its authenticity and trust will move to the last category, the pico influences. This is the category of people with less than 1,000 connections: the level of you, me and my neighbor with her dog. These are the people that we know in (e) real life and with whom we have a relationship. The interesting thing is that we have then come full circle, back to where we were historically, when we trusted people who were actually very well known to us.

## 5 윗글의 제목으로 가장 적절한 것은?

25007-0113

- ① Trends and Predictions in Influencer Marketing
- ② Impact of Digital Marketing on Business Growth
- ③ Improving Brand Image Using Customer Reviews
- ④ Utilizing Social Media to Appeal to the Younger Generation
- ⑤ Enhancing Customer Loyalty with Positive Brand Experiences

## 6 밑줄 친 (a)~(e) 중에서 문맥상 낱말의 쓰임이 적절하지 않은 것은?

25007-0114

- ① (a)
- ② (b)
- ③ (c)
- ④ (d)
- ⑤ (e)

### Sentence Structure

- The interesting thing is [that we have then come full circle, back to {where we were historically}, {when we trusted people who were actually very well known to us}].

[ ]는 주격 보어 역할을 하는 명사절이다. 첫 번째 { }는 의문사 where가 이끄는 명사절로서 전치사 to의 목적어 역할을 하고, 두 번째 { }는 앞선 { }를 구체적으로 설명하고 있다.

### Word Search 주어진 문장에 들어갈 적절한 영어 단어를 본문에서 찾아 쓰시오. (필요시 형태를 바꿀 것)

1. Artists often p\_\_\_\_\_ the world in unique and imaginative ways.
2. Our team's winning s\_\_\_\_\_ is a combination of strong defense and quick counterattacks.
3. The website is considered t\_\_\_\_\_ because it provides accurate and reliable information.

**Exercise 7** 어휘

다음 글의 밑줄 친 부분 중, 문맥상 낱말의 쓰임이 적절하지 않은 것은?

25007-0115

From an epistemic perspective, a central question concerns the extent to which advertising is expected to be truthful. Advertisements often use widely exaggerated or metaphorical claims, a practice called “puffery,” which, in contrast to misleading advertising, is legally ① permitted in some countries, for example, the United States. Its legality is based on the assumption that individuals will not take such claims literally or act on them. This assumption, however, is ② confirmed by empirical evidence that shows that consumers *do* in fact react to puffed statements. Even though some consumers may indeed recognize puffery as what it is, others are more vulnerable and take it at face value. This practice thus also raises issues of ③ fairness: is it legitimate for companies to make false statements that better-informed or more reflective consumers will not believe, but others will fall prey to? Even sophisticated consumers ④ suffer from such strategies, however, because they have to double-check which advertisements to take seriously. In an analysis of the treatment of puffery in US law, legal scholar David Hoffman argues that it should be understood as ⑤ causing a negative externality: it creates “informational burdens currently borne by buyers, without compensation from sellers.”

\* epistemic: 인식론적인 \*\* puffery: 과대광고

\*\*\* externality: 외부 효과(어떤 경제 주체의 행위가 제삼자에게 기대하지 않은 편익이나 비용을 발생시키는 현상)

**Sentence Structure**

- From an epistemic perspective, a central question concerns [the extent {to which advertising is expected to be truthful}].

[ ]는 concerns의 목적어이고, { }는 the extent를 수식하는 관계절이다.

**Word Search**

주어진 문장에 들어갈 적절한 영어 단어를 본문에서 찾아 쓰시오. (필요시 형태를 바꿀 것)

- The lawyer questioned the l \_\_\_\_\_ of the contract due to its unclear terms.
- The young birds in the nest were v \_\_\_\_\_ without their mother's protection.
- The s \_\_\_\_\_ gentleman impressed everyone with his extensive knowledge of art.

## Exercise 8 문장 삽입

글의 흐름으로 보아, 주어진 문장이 들어가기에 가장 적절한 곳은?

25007-0116

Not all ecological systems and spaces have the same ecosystem services and natural resource value.

Environmental economists often aim to put an economic valuation on ecosystem service. The reason for this is that ecosystem services historically have been underconsidered and underappreciated in environmental decision-making and policy. ( ① ) Placing a monetary value on them increases their salience. ( ② ) The economic value of global ecosystem services is estimated to be \$125 trillion per year. ( ③ ) This puts into perspective just how crucial well-functioning ecological systems are to human well-being as well as the extent to which human systems are intertwined with and dependent upon them. ( ④ ) However, site- or system-specific economic valuations are often more important to environmental decision-making than is global or macro evaluation. ( ⑤ ) For example, an average hectare of open ocean provides fewer services than does an average hectare of reef, and an average hectare of desert provides fewer than does an average hectare of tropical rainforest.

\* salience: 중요성 \*\* intertwine: 밀접하게 관련짓다 \*\*\* reef: 암초

### Sentence Structure

- This **puts into perspective** [{just how crucial well-functioning ecological systems are to human well-being} **as well as** {the extent <to which human systems are intertwined with and dependent upon them>}].  
[ ]는 ‘~을 분명하게 알 수 있게 하다’의 의미를 나타내는「put ~ into perspective」의 동사 put의 목적어 역할을 한다. [ ] 안의 두 개의 { }는 as well as로 연결되어 있고, < >는 the extent를 수식하는 관계절이다.

**Word Search** 주어진 문장에 들어갈 적절한 영어 단어를 본문에서 찾아 쓰시오. (필요시 형태를 바꿀 것)

1. A young businessperson received **m** \_\_\_\_\_ support from investors to start his new business.
2. Eating a balanced diet is **c** \_\_\_\_\_ for maintaining good health and preventing illness.
3. The small island's economy is heavily **d** \_\_\_\_\_ on tourism for its survival.

**Exercise 9** 요약문 완성

다음 글의 내용을 한 문장으로 요약하고자 한다. 빈칸 (A), (B)에 들어갈 말로 가장 적절한 것은?

25007-0117

Natural laws are not things that we can see or touch or hear; they are — according to Scottish philosopher David Hume — only descriptions of past groupings of events. For instance, consider the series of events: I let go of the pen; the pen falls; I let go of the pen; the pen falls; I let go of the pen; and so on. This series *may* be explained by a set of laws, such as gravity and inertia. But this series — by itself — simply *describes* events that have happened in the past; it does not tell us *why* pens behave that way, and it does not tell us that pens will always behave that way. And even if those past events happened because of laws, why believe those laws *will* continue to govern events in the future? If we say laws existed in the past, we need some additional law that tells us those laws will exist in the future. But, it seems we can only describe the way those laws behaved in the past.

\* inertia: 관성



Natural laws, which David Hume claims merely \_\_\_ (A) \_\_\_ past grouping of events, do not guarantee future behavior since they lack an explanation for their \_\_\_ (B) \_\_\_ validity.

- |           |    |             |
|-----------|----|-------------|
| (A)       |    | (B)         |
| ① distort | ⋯⋯ | universal   |
| ③ track   | ⋯⋯ | statistical |
| ⑤ glorify | ⋯⋯ | statistical |

- |                |    |            |
|----------------|----|------------|
| (A)            |    | (B)        |
| ② represent    | ⋯⋯ | continuing |
| ④ oversimplify | ⋯⋯ | continuing |

**Sentence Structure**

- But this series — by itself — simply *describes* events [that have happened in the past]; it does not tell us [*why* pens behave that way], and it does not tell us [that pens will always behave that way].  
 첫 번째 [ ]는 events를 수식하는 관계절이다. 두 번째와 세 번째 [ ]는 각각 tell의 직접목적어 역할을 하는 명사절이다.

**Word Search**

주어진 문장에 들어갈 적절한 영어 단어를 본문에서 찾아 쓰시오. (필요시 형태를 바꿀 것)

1. The ball fell to the ground because of **g** \_\_\_\_\_, the force that pulls things down.
2. The new laws will **g** \_\_\_\_\_ how businesses operate in this country.
3. If you need **a** \_\_\_\_\_ help with your homework, please ask your teacher after class.

## Exercise 10 어휘

다음 글의 밑줄 친 부분 중, 문맥상 낱말의 쓰임이 적절하지 않은 것은?

25007-0118

Even though the universe is consistently inflating, it is still orderly. There are consistent rules that can be observed and measured. There are ① dependable physical principles that govern the relationship of one particle to another at varying scales. Three hundred years ago, the brilliant mathematician Sir Isaac Newton formulated the laws of motion that define the movement of large objects in physical space. These are the reliable and reproducible physical rules that ② allow us to calculate the accurate trajectory of an artillery shell or a rocket ship. These apply to the scale of objects that we can observe ③ directly and are not microscopic in size; however, in the last century, a new set of quantum rules has been identified that govern how the atomic level operates. Some of these quantum principles contradict our ordinary senses. At this microscopic scale, the actions among particles ④ confirm our established expectations of clear-cut relationships between physical causes and effects. Instead, quantum measurements reveal inherent uncertainties about the relationship between one object and another. Yet, these ⑤ built-in uncertainties are just as relevant to our lives as those Newtonian forces that govern what happens when two cars crash into each other.

\* trajectory: 궤도, 탄도 \*\* artillery shell: 포탄 \*\*\* quantum: 양자

### Sentence Structure

- Three hundred years ago, [the brilliant mathematician Sir Isaac Newton] formulated [the laws of motion {that define the movement of large objects in physical space}].

첫 번째 [ ]는 문장의 주어이고, 두 번째 [ ]는 formulated의 목적어이다. { }는 the laws of motion을 수식하는 관계절이다.

### Word Search 주어진 문장에 들어갈 적절한 영어 단어를 본문에서 찾아 쓰시오. (필요시 형태를 바꿀 것)

1. Kate's **c** \_\_\_\_\_ effort in practicing English resulted in significant improvement in her speaking skills.
2. The experiment must have clear instructions to ensure the results are **r** \_\_\_\_\_ by other researchers.
3. The politician's promises to lower taxes **c** \_\_\_\_\_ his voting record of supporting tax increases.

## Exercise 11~12

## 1지문 2문항

[11~12] 다음 글을 읽고, 물음에 답하십시오.

Humans have an extremely extended period of brain development. This is especially true for circuits that mediate behavioral control, such as the prefrontal cortex, which do not fully mature until a person's early twenties. Until that time, synapses are still being modified on a (a) massive scale. This provides plentiful opportunity for these circuits to be shaped by experience and is likely one of the key factors in our ability to successfully populate what has been called the "cognitive niche." Rather than being adapted for specific environments, with a (b) limited set of hardwired, instinctive behaviors, we have evolved cognitive flexibility and responsiveness, allowing us to adapt ourselves to our individual environments. Repeated patterns are reinforced and habitual modes of behavior emerge. We gradually become ourselves.

But at some point we have to stop constantly becoming and just get on with things — important things like building a career or finding a mate. That means we have to consolidate the adaptations we have made and (c) restrict further changes. We can't have runaway positive feedback loops forever — we have to maintain these neural configurations to (d) remain ourselves. The periods of wholesale plasticity last considerably longer in behavioral and cognitive circuits than in sensory ones, but they still close as we reach adulthood. The plasticity processes themselves will have progressively (e) expanded the "degrees of freedom" of the developing brain, magnifying initial biases by both positive reinforcement and progressive elimination of connections mediating less-favored states. But the biochemistry of the brain also changes with maturation, so that mechanisms of plasticity and flexibility get replaced by mechanisms of stability and maintenance.

\* cognitive niche: 인지적 적소(인간의 인지 능력이 특화된 생태학적 위치)

\*\* consolidate: 공고히 하다 \*\*\* configuration: 구성, 배열

**11** 윗글의 제목으로 가장 적절한 것은?

25007-0119

- ① Ways to Trick Our Brain into Forming Lasting Habits
- ② Why a Flexible Mindset Contributes to Brain Development
- ③ The Aging Brain: Myths and Realities of Cognitive Decline
- ④ How Our Brain Responds to Changes in the Physical Environment
- ⑤ From Flexible to Stable: The Gradual Maturing of the Human Brain

**12** 밑줄 친 (a)~(e) 중에서 문맥상 낱말의 쓰임이 적절하지 않은 것은?

25007-0120

- ① (a)
- ② (b)
- ③ (c)
- ④ (d)
- ⑤ (e)

**Sentence Structure**

- This [provides plentiful opportunity {for these circuits to be shaped by experience}] and [is likely one of the key factors in our ability {to successfully populate <what has been called the “cognitive niche.”>}]
- 두 개의 [ ]는 and로 연결된 문장의 술어이다. 첫 번째 { }는 these circuits를 의미상의 주어로 하여 plentiful opportunity를 수식하는 to부정사구이다. 두 번째 { }는 our ability의 구체적 내용을 설명하는 to부정사구이고, 그 안의 < >는 populate의 목적어 역할을 하는 명사절이다.

**Word Search** 주어진 문장에 들어갈 적절한 영어 단어를 본문에서 찾아 쓰시오. (필요시 형태를 바꿀 것)

1. The old man had an i\_\_\_\_\_ distrust of strangers.
2. The chameleon’s ability to change its skin color is an a\_\_\_\_\_ that helps it hide from predators.
3. Our s\_\_\_\_\_ organs, like our eyes and ears, help us perceive the world around us.

## Exercise 1 어휘

다음 글의 밑줄 친 부분 중, 문맥상 낱말의 쓰임이 적절하지 않은 것은?

25007-0121

Inspired by the pioneering work of the psychologists Daniel Kahneman and the late Amos Tversky, the field of psychology has cataloged a large inventory of behavioral anomalies in which people clearly ① violate the predictions and prescriptions of standard economic models. It is common, for example, for someone to be ② willing to drive across town to save \$10 on a \$20 clock radio, but unwilling to do so to save \$10 on a \$1,000 television set. Yet the benefit of making the drive is \$10 in each case. So if the implicit cost of the drive were ③ less than \$10, a rational person would drive across town in both cases. People often explain their ④ reluctance to make the drive for the television by saying the \$10 savings is such a small percentage of its price. But a rational person reckons benefits and costs in ⑤ relative terms, not as percentages.

\* behavioral anomaly: 이상 행동 \*\* reckon: 생각하다

## Sentence Structure

- **It** is common, for example, [**for someone** to be willing to drive across town to save \$10 on a \$20 clock radio, but unwilling to do so to save \$10 on a \$1,000 television set].

It은 형식상의 주어이고, [ ]는 내용상의 주어이다. for someone은 부정사구 to be ~의 의미상의 주어를 나타낸다.

## Word Search

주어진 문장에 들어갈 적절한 영어 단어를 본문에서 찾아 쓰시오. (필요시 형태를 바꿀 것)

1. The designer's latest collection was i \_\_\_\_\_ by vintage fashion trends.
2. There was a noticeable r \_\_\_\_\_ among the employees to adopt the new policy.
3. In order to solve the complex problem, we need a r \_\_\_\_\_ and systematic approach.

## Exercise 2 문장 삽입

글의 흐름으로 보아, 주어진 문장이 들어가기에 가장 적절한 곳은?

25007-0122

They walked to the offices of their Baby Boomer peers, emailed Gen X colleagues, and texted Millennials.

Regardless of their generation, everyone wants to be valued, respected, and heard. But each one of us might express our thoughts and receive information differently. ( ① ) One of my clients was struggling with how some of their Baby Boomer employees were trying to build personal relationships with Millennial employees. ( ② ) A few of these employees read articles that recommended specific methods for communicating with each generation. ( ③ ) The Boomer employees then went on to use this information to inform how they communicated with all of their coworkers of various generations. ( ④ ) On the surface, this seemed fine, but it soon started to stir up some controversy because people did not understand why they were getting an email, when someone else was getting a face-to-face conversation. ( ⑤ ) By limiting in-person conversation to only certain coworkers, these employees unintentionally made others feel left out and undervalued.

### Sentence Structure

- The Boomer employees then went on to use this information [to inform {how they communicated with all of their coworkers of various generations}].  
[ ]는 목적을 나타내는 to부정사구이고, 그 안의 { }는 inform의 목적어 역할을 하는 명사절이다.

**Word Search** 주어진 문장에 들어갈 적절한 영어 단어를 본문에서 찾아 쓰시오. (필요시 형태를 바꿀 것)

1. Many in the younger **g** \_\_\_\_\_ are pushing for social change.
2. She **u** \_\_\_\_\_ deleted the important file from her computer.
3. The decision to ban certain books from the library sparked a **c** \_\_\_\_\_ among students.

**Exercise 3** 요약문 완성

다음 글의 내용을 한 문장으로 요약하고자 한다. 빈칸 (A), (B)에 들어갈 말로 가장 적절한 것은?

25007-0123

Our species has been making music most likely for as long as we've been human. It seems to be a permanent part of us. The oldest known musical instruments date back to some 40,000 years ago. Among the most intriguing of these are delicate bone flutes, found in what is now southern Germany. These discoveries testify to the advanced technology that our ancestors applied to create music: the finger holes are carefully bevelled to allow the musician's fingers to make a tight seal; and the distances between the holes appear to have been precisely measured, perhaps to correspond to a specific musical scale. This time period corresponds to the last glaciation episode in the Northern Hemisphere — life could not have been easy for people living at that time. Yet time, energy, and the skills of craftworkers were used for making abstract sounds “of the least use ... to daily habits of life.” So, music must have been very meaningful and important for them.

\* bevel: 비스듬히 자르다 \*\* glaciation: 빙하



The fact that humans living 40,000 years ago had attentively crafted musical instruments employing \_\_\_ (A) \_\_\_ methods despite their harsh living conditions reflects the \_\_\_ (B) \_\_\_ they placed on music.

- |                 |       |                 |       |
|-----------------|-------|-----------------|-------|
| (A)             |       | (A)             |       |
| ① sophisticated | ..... | ② sophisticated | ..... |
| ② significance  |       | ③ complexity    | ..... |
| ③ flexible      | ..... | ④ outdated      | ..... |
| ④ complexity    |       | ⑤ essence       |       |
| ⑤ outdated      | ..... |                 |       |
| ⑥ significance  |       |                 |       |

**Sentence Structure**

- [Among the most intriguing of these] are [delicate bone flutes, {found in what is now southern Germany}].  
전치사구인 첫 번째 [ ]가 문두에 위치하면서, 문장의 주어인 두 번째 [ ]가 술어동사 are 다음에 놓였다. { }는 delicate bone flutes를 추가적으로 설명하는 분사구이다.

**Word Search** 주어진 문장에 들어갈 적절한 영어 단어를 본문에서 찾아 쓰시오. (필요시 형태를 바꿀 것)

1. Experts will **t** \_\_\_\_\_ to the safety and effectiveness of the new medication during the trial.
2. The art exhibit featured highly **i** \_\_\_\_\_ pieces that sparked a lot of conversation.
3. The professor's lecture covered complex **a** \_\_\_\_\_ concepts in mathematics.

## Exercise 4 어휘

(A), (B), (C)의 각 네모 안에서 문맥에 맞는 낱말로 가장 적절한 것은?

25007-0124

Sometimes, even seemingly unlucky starts turn out to make long-run success more likely. Gladwell cites the experience of Jews who immigrated to New York in the early twentieth century and went on to prosper in the garment industry. Many raised children who graduated from law school, only to be (A) rejected / hired by leading New York law firms, which in those days hired mostly lawyers from wealthy Protestant families. Jewish graduates were often left with few better options than to start small firms of their own. Those firms often specialized in cases that the elite law firms felt were (B) above / beneath them, such as the litigation of hostile corporate takeovers. The lawyers raised by garment workers were thus often the only ones who had developed the expertise to capitalize on the explosive growth of hostile takeover litigation that occurred in the 1970s and 1980s. By (C) sharing / dominating that new market, they went on to earn vastly more than the lawyers in the firms that had earlier shunned them.

\* litigation: 소송 \*\* shun: 기피하다

- |            | (A)   | (B)     | (C)              |
|------------|-------|---------|------------------|
| ① rejected | ..... | above   | ..... sharing    |
| ② hired    | ..... | above   | ..... sharing    |
| ③ rejected | ..... | beneath | ..... dominating |
| ④ hired    | ..... | beneath | ..... dominating |
| ⑤ rejected | ..... | beneath | ..... sharing    |

### Sentence Structure

- The lawyers [raised by garment workers] were thus often the only ones [who had developed the expertise {to capitalize on the explosive growth of hostile takeover litigation <that occurred in the 1970s and 1980s>}].  
 첫 번째 [ ]는 The lawyers를 수식하는 분사구이고, 두 번째 [ ]는 the only ones를 수식하는 관계절이다. { }는 the expertise를 수식하는 to부정사구이고, < >는 the explosive growth of hostile takeover litigation을 수식하는 관계절이다.

**Word Search** 주어진 문장에 들어갈 적절한 영어 단어를 본문에서 찾아 쓰시오. (필요시 형태를 바꿀 것)

1. The singer's latest album received an **e**\_\_\_\_\_ response from fans.
2. His **e**\_\_\_\_\_ in engineering made him the ideal candidate for the project.
3. The new technology has **v**\_\_\_\_\_ improved efficiency in the workplace.

## Exercise 5~6

## 1지문 2문항

[5~6] 다음 글을 읽고, 물음에 답하십시오.

Let's take a classical example from cognitive psychology: the effect of word processing depth. Imagine that I present a list of sixty words to three groups of students. I ask the first group to decide whether the words' letters are upper- or lowercase; the second group, whether the words rhyme with "chair"; and the third, whether they are animal names or not. Once the students are finished, I give them a (a) memory test. Which group remembers the words best? Memory turns out to be much (b) better in the third group, who processed the words in depth, at the meaning level (75 percent success), than in the other two groups, who processed the more superficial sensory aspects of the words, either at the letter level (33 percent success) or the rhyme level (52 percent success). We do find a weak implicit and unconscious trace of the words in all groups: learning (c) leaves its subliminal mark within the spelling and phonological systems. However, only in-depth semantic processing guarantees explicit, detailed memory of the words. The same phenomenon (d) disappears at the level of sentences: students who make the effort to understand sentences on their own, without teacher guidance, show much better retention of information. This is a general rule, which the American psychologist Henry Roediger states as follows: "Making learning conditions (e) more difficult, thus requiring students to engage more cognitive effort, often leads to enhanced retention."

\* subliminal: 잠재의식적인 \*\* phonological: 음운의 \*\*\* semantic: 의미적인

## 5 읽글의 제목으로 가장 적절한 것은?

25007-0125

- ① Ways to Support Children with Learning Difficulties
- ② Motivation and Its Impact on Memory Retention Rate
- ③ How the Depth of Semantic Processing Influences Memory
- ④ Subconscious Language Learning: Reality or Science Fiction?
- ⑤ The Language We Speak Can Influence Our Way of Thinking

## 6 밑줄 친 (a)~(e) 중에서 문맥상 낱말의 쓰임이 적절하지 않은 것은?

25007-0126

- ① (a)
- ② (b)
- ③ (c)
- ④ (d)
- ⑤ (e)

### Sentence Structure

- I ask the first group [to decide whether the words' letters are upper- or lowercase]; [the second group, whether the words rhyme with "chair"]; and [the third, whether they are animal names or not].

첫 번째 [ ]는 문장의 목적격 보어 역할을 하는 to부정사구이다. 두 번째와 세 번째 [ ]에서는 각각 the second group과 the third의 뒤에 to decide가 생략된 것으로 이해할 수 있으며, 두 개의 [ ]는 모두 I ask에 이어진다.

### Word Search 주어진 문장에 들어갈 적절한 영어 단어를 본문에서 찾아 쓰시오. (필요시 형태를 바꿀 것)

1. His understanding of the topic was only s\_\_\_\_\_ ; he didn't get the deeper concepts.
2. The detective found a t\_\_\_\_\_ of evidence that led to the suspect.
3. The teacher's g\_\_\_\_\_ helped the students improve their writing skills.

## Exercise 7 어휘

다음 글의 밑줄 친 부분 중, 문맥상 낱말의 쓰임이 적절하지 않은 것은?

25007-0127

A successful farming community could support in a small region a much greater population than the foragers could have. There were, however, very significant ① downsides to this new way of life. First of all, storms, droughts, floods, torrential rains, and other severe weather anomalies could be ② disastrous for a farming community while posing only a major nuisance to foragers. The latter, with their ③ minimal lightweight possessions, could fairly easily up and move to some other area where the damage was not so great. But, more importantly, the natural home they depended on was much ④ more likely to be severely damaged than were the crops and structures the agricultural community relied on. By replacing their natural home with an ⑤ artificial construction, the farmers, paradoxically enough, had made themselves more defenseless to natural disasters; in fact, natural events that were not at all disasters for the foragers became disasters for them.

\* forager: 수렵채집인 \*\* anomaly: 이변 \*\*\* nuisance: 골칫거리, 성가신 것[사람]

### Sentence Structure

- **The latter**, with their minimal lightweight possessions, could fairly easily up and move to some other area [where the damage was not so great].

The latter는 앞 문장에 나온 foragers를 의미하고, [ ]는 some other area를 수식하는 관계절이다.

### Word Search

주어진 문장에 들어갈 적절한 영어 단어를 본문에서 찾아 쓰시오. (필요시 형태를 바꿀 것)

1. Nuclear weapons p \_\_\_\_\_ a threat to everyone.
2. The necklace is one of her most treasured p \_\_\_\_\_.
3. Farmers here still plant and harvest their c \_\_\_\_\_ by hand.

## Exercise 8 문장 삽입

글의 흐름으로 보아, 주어진 문장이 들어가기에 가장 적절한 곳은?

25007-0128

But even allowing nonbasic terms and even allowing the highly specialized vocabulary of the paint industry, the distinctions that languages make in the color space are astronomically small in comparison to well over 2 million distinctions in color that the human eye can discern.

There are special situations in which people may know dozens, if not hundreds, of distinct words for colors. One famous brand of house paints has more than two thousand colors in its commercial palette. ( ① ) Many of these are labeled with unique (and decidedly nonbasic) English names: *violet posy*, *wing commander*, *Aztec tan*. ( ② ) Even in highly specialized, technical vocabularies, the total inventory of color terms in use makes less than one-tenth of 1 percent of the discernible distinctions in color that the human visual system can make. ( ③ ) The everyday vocabulary that most people use will be one hundred times less than that again. ( ④ ) Our perceptual experience is rich, but our language comes nowhere close to that richness. ( ⑤ ) If you think that language is good for capturing perceptual experience, think again.

\* astronomically: 어마어마하게, 천문학적으로 \*\* discern: 식별하다 \*\*\* inventory: 목록

### Sentence Structure

- There are special situations [in which people may know dozens, { **if not** hundreds}, of distinct words for colors].

[ ]는 special situations를 수식하는 관계절이고, { }는 삽입구로, 「if not ~」은 ‘~은 아닐지라도’라는 의미이다.

**Word Search** 주어진 문장에 들어갈 적절한 영어 단어를 본문에서 찾아 쓰시오. (필요시 형태를 바꿀 것)

1. There are no obvious **d** \_\_\_\_\_ between the two designs.
2. Each box in the warehouse was **l** \_\_\_\_\_ with its contents.
3. Maps are a **v** \_\_\_\_\_ tool for learning.

**Exercise 9** 요약문 완성

다음 글의 내용을 한 문장으로 요약하고자 한다. 빈칸 (A), (B)에 들어갈 말로 가장 적절한 것은?

25007-0129

In Britain, large open areas of land known as the *commons* were the property of land-owning nobility but were accessible for use by peasants. They used the commons to conduct small-scale agriculture, to collect wood for fuel and cooking, and to raise small amounts of livestock for their families. As global demand for wool to be used in clothing and other goods increased, landowners sought more grazing land to increase wool production, so they privatized the commons, fencing them off and thus cutting off access to the peasants. By this process of the *enclosure* of the commons, peasants were cut off from land that had been their primary resource for survival for centuries. Today, there are interesting correlations between the physical commons of English pasturelands and the digital commons of the internet. Both are rich with opportunities for self-subsistence, expression, flourishing; both are full of challenges from *enclosure* and *landlords* (e.g., platform owners who charge fees for access or use).

\* grazing land: 목초지 \*\* self-subsistence: 자립



In Britain, as the demand for wool increased, peasants' access to the commons was \_\_\_\_\_ (A) \_\_\_\_\_, and this \_\_\_\_\_ (B) \_\_\_\_\_ contemporary situations we are facing in the digital world.

- |  |  |
|--|--|
| <p>(A)                      (B)</p> <p>① disturbed    .....    contrasts</p> <p>③ blocked     .....    resembles</p> <p>⑤ restricted   .....    resolves</p> | <p>(A)                      (B)</p> <p>② guaranteed .....    mirrors</p> <p>④ expanded    .....    parallels</p> |
|--|--|

**Sentence Structure**

- [As {global demand for wool to be used in clothing and other goods} increased], landowners sought more grazing land [to increase wool production], so they privatized the commons, [fencing them off] and thus [cutting off access to the peasants].

첫 번째 [ ]는 '~하면서'라는 의미의 As가 이끄는 부사절이고, 그 안의 { }가 주어이다. 두 번째 [ ]는 목적을 나타내는 to부정사 구이고, 세 번째와 네 번째 [ ]는 모두 they를 의미상의 주어로 하는 분사구문이다.

**Word Search**

주어진 문장에 들어갈 적절한 영어 단어를 본문에서 찾아 쓰시오. (필요시 형태를 바꿀 것)

- The experiments were **c** \_\_\_\_\_ by scientists.
- The farmer tended to his **l** \_\_\_\_\_ early each morning.
- Air traffic control has been **p** \_\_\_\_\_.

## Exercise 10 어휘

다음 글의 밑줄 친 부분 중, 문맥상 낱말의 쓰임이 적절하지 않은 것은?

25007-0130

The reason listening can be so difficult appears to be our narcissistic disposition. Too often, we ① pretend to be listening while our mind is racing in trying to think of something clever. However, being clever is not being wise. In addition, to exacerbate our narcissistic tendencies, there is also the kind of listening with half an ear that ② presumes that we already know what the other person is going to say. I am referring to an inattentive listening, only waiting for a chance to speak, and even becoming ③ impatient, wishing to get rid of the other person. As the philosopher and poet Ralph Waldo Emerson once said, ‘There is a difference between truly listening and waiting for your turn to talk.’ This ④ reluctance to interrupt and get a word in can be quite powerful. Some people just want to hear themselves speak just to confirm and validate their ⑤ existence. It has been said that big egos have little ears.

\* disposition: 성향 \*\* exacerbate: 악화시키다

### Sentence Structure

- In addition, to exacerbate our narcissistic tendencies, there is also the kind of listening with half an ear [that presumes that we already know { what the other person is going to say }].  
[ ]는 the kind of listening with half an ear를 수식하는 관계절이고, { }는 know의 목적어 역할을 하는 명사절이다.

**Word Search** 주어진 문장에 들어갈 적절한 영어 단어를 본문에서 찾아 쓰시오. (필요시 형태를 바꿀 것)

1. The p \_\_\_\_\_ read her latest poem at the restaurant.
2. Please don't i \_\_\_\_\_ me while I'm talking.
3. She seemed to need his admiration to v \_\_\_\_\_ her as a person.

## Exercise 11~12 1지문 2문항

[11~12] 다음 글을 읽고, 물음에 답하십시오.

The bank account analogy helps express why increased agricultural production must be accompanied by fertilizer use. Every time you harvest a crop and eat it, the nitrogen (and other nutrients) in those plants, the very nutrients that make that crop good food, are taken out of the soil and moved to wherever you are. Some of those nutrients (a) accumulate in your body (if you are growing), but most pass through. Either way, unless you and your waste are returned to the farm, there is a net (b) loss of nutrients from the soil — a net withdrawal from the nutrient bank. When there were relatively few people, most of whom lived, went to the bathroom, and died on or near the farm, leaving fields uncultivated or planting legumes and plowing them under was a reasonably (c) sustainable way to produce food. But for eight billion people? Or for ten? The food required to feed all of us requires a lot of nitrogen to be removed from farms, and it needs to be (d) replaced, or the soil bank account of nitrogen will run out. This means feeding the world requires industrially produced nitrogen fertilizer, at least for the foreseeable future, until we figure out a safe and effective way to return the nutrients passing through humans to the farm soil where they came. In other words, we thrive because of our innovations in (e) eliminating nitrogen.

\* analogy: 비유 \*\* legume: 콩과(科) 식물 \*\*\* plow under: (작물 등을) 갈아엎다

## 11 읽글의 제목으로 가장 적절한 것은?

25007-0131

- ① Is Nitrogen the Key Element of Biodiversity?
- ② Why Nitrogen Fertilizer Is Essential in Today's World
- ③ The Total Amount in a Bank Account: A Mirror of Greed
- ④ Increasing Demand to Protect the Soil Against Chemical Use
- ⑤ Which Is the Cause of the Climate Crisis, Nitrogen or People?

## 12 밑줄 친 (a)~(e) 중에서 문맥상 낱말의 쓰임이 적절하지 않은 것은?

25007-0132

- ① (a)
- ② (b)
- ③ (c)
- ④ (d)
- ⑤ (e)

### Sentence Structure

- [Every time you harvest a crop and eat it], [the nitrogen (and other nutrients) in those plants], [the very nutrients that make that crop good food], are taken out of the soil and moved to [wherever you are].  
 첫 번째 [ ]는 '~할 때마다'라는 의미의 Every time이 이끄는 부사절이고, 두 번째와 세 번째 [ ]는 의미상 동격 관계를 이룬다. 네 번째 [ ]는 복합관계절로 여기에서 wherever는 '~하는 곳이 어디든지'라는 뜻이다.

**Word Search** 주어진 문장에 들어갈 적절한 영어 단어를 본문에서 찾아 쓰시오. (필요시 형태를 바꿀 것)

1. The thunderstorm was **a** \_\_\_\_\_ by high winds.
2. Farmers sort the vegetables when they **h** \_\_\_\_\_.
3. You can make **w** \_\_\_\_\_ of up to \$500 a day.

## Exercise 1 어휘

다음 글의 밑줄 친 부분 중, 문맥상 낱말의 쓰임이 적절하지 않은 것은?

25007-0133

Must societies ‘reproduce’ their territory? On the one hand, history is full of territorial ① conflicts; a social system that has its territory removed is doomed to fail. What role does the territory play in the metabolic reproduction of the social system’s population? Of key significance is the fact that territory offers the population a legitimate ② physical ‘common living space’, that is, it serves as a ‘repository for humans and their infrastructures’. This ‘repository function’ provides the opportunity to participate in the ③ consumption of the so-called ‘free goods’, the ecosystem services within the territory (for example, clean air and water). In most cases, however, it means more than this. The state is in some sense answerable to the ‘common good’ and thus to ensuring conditions supporting the reproduction of its human subjects. In any case, at least within its territory, it must ensure that their metabolic reproduction is ④ unattainable. The territory is therefore meaningful in ⑤ containing natural resources which economic processes can appropriate. It also provides an outlet for the depositing of waste products from these processes, and it is a source of various non-provisioning ecosystem services.

\* metabolic: (신진) 대사의 \*\* repository: 저장소 \*\*\* infrastructure: 하부 구조

## Sentence Structure

- The state is in some sense answerable [to the ‘common good’] and thus [to ensuring conditions {supporting the reproduction of its human subjects}].

두 개의 [ ]가 and로 연결되어 answerable에 이어진다. 두 번째 [ ] 안의 { }는 conditions를 수식하는 분사구이다.

## Word Search

주어진 문장에 들어갈 적절한 영어 단어를 본문에서 찾아 쓰시오. (필요시 형태를 바꿀 것)

1. They have refused to allow the army to be stationed in their t\_\_\_\_\_.
2. Her passport seemed l\_\_\_\_\_, but it was found to have been altered.
3. Remember that councils should be a\_\_\_\_\_ to the people who elect them.

## Exercise 2 문장 삽입

글의 흐름으로 보아, 주어진 문장이 들어가기에 가장 적절한 곳은?

25007-0134

Some people find such screens to be so impersonal that they provoke a suspicious, even aggressive, response.

There are some situations where physical barriers are both sensible and necessary for the protection of the worker. There are classic examples of this within the prison service and of how arrangements can be made for the safety of visitors. ( ① ) But many reception areas for public services have, from time to time, employed security screens in the hope of discouraging violence or abusive behaviour and for the protection of staff. ( ② ) These have not always worked, however, and have sometimes given the message that violent behaviour is being expected. ( ③ ) They much prefer to create an open, warm and human environment that respects the individual and encourages them in turn to behave respectfully towards the worker. ( ④ ) It is also possible that screens can put confidentiality at risk if people feel that they have to speak more loudly in order to make themselves heard. ( ⑤ ) Screens in GP surgeries are good examples of this.

\* confidentiality: 비밀 \*\* GP surgery: 지역 보건 진료소

### Sentence Structure

- They much prefer to create an open, warm and human environment [that {respects the individual} and {encourages them in turn to behave respectfully towards the worker}].  
[ ]는 an open, warm and human environment를 수식하는 관계절이고, 그 안에 두 개의 { }가 and로 연결되어 관계절의 술부를 구성한다.

**Word Search** 주어진 문장에 들어갈 적절한 영어 단어를 본문에서 찾아 쓰시오. (필요시 형태를 바꿀 것)

1. Rows of identical beds in dull grey rooms make hospitals seem **i** \_\_\_\_\_.
2. The officers on patrol became **s** \_\_\_\_\_ of the man in a car.
3. If we criticize her, she gets **a** \_\_\_\_\_ and starts shouting.

**Exercise 3** 요약문 완성

다음 글의 내용을 한 문장으로 요약하고자 한다. 빈칸 (A), (B)에 들어갈 말로 가장 적절한 것은?

25007-0135

Decoding is a verbal activity that regards its object as a set of signals; each signal carries a specific meaning determined by a code. The object of decoding may be verbal or nonverbal. The nonverbal object, however, becomes in the process of decoding analogous to verbal objects, that is, it is viewed as a set of signals. Decoding an enemy's message begins with the belief that the apparently random signals conceal a coherent meaning. As is the case with explanation, decoding aims to unify disparate facts. While explanation includes the particular covered by a general law, decoding substitutes one element with another in accordance with a rule that may be individual to the particular case: the enemy's second message may or may not be written in the same code as the first. The decoder cannot rely on seemingly similar cases to provide the right code — the apparent similarity may be misleading. By contrast, similar cases must be similarly explained, because explanations assume general, coherent rules common to all relevant cases.

\* analogous to: ~과 유사한 \*\* coherent: 일관된 \*\*\* disparate: 이질적인



Decoding is the process of interpreting signals, often requiring \_\_\_ (A) \_\_\_ rules to particular cases, in contrast to explanation which relies on consistent rules across \_\_\_ (B) \_\_\_ cases.

- |               |                  |               |               |
|---------------|------------------|---------------|---------------|
| (A)           | (B)              | (A)           | (B)           |
| ① generalized | ..... random     | ② generalized | ..... unique  |
| ③ specific    | ..... accidental | ④ specific    | ..... similar |
| ⑤ specific    | ..... complex    |               |               |

**Sentence Structure**

- Decoding is a verbal activity [that regards its object as a set of signals]; each signal carries a specific meaning [determined by a code].  
 첫 번째 [ ]는 a verbal activity를 수식하는 관계절이고, 두 번째 [ ]는 a specific meaning을 수식하는 분사구이다.

**Word Search**

주어진 문장에 들어갈 적절한 영어 단어를 본문에서 찾아 쓰시오. (필요시 형태를 바꿀 것)

- Mark could barely **c** \_\_\_\_\_ his disappointment.
- A series of **a** \_\_\_\_\_ unconnected events led to her resignation.
- They have a **v** \_\_\_\_\_ agreement with him.

## Exercise 4 어휘

(A), (B), (C)의 각 네모 안에서 문맥에 맞는 낱말로 가장 적절한 것은?

25007-0136

Carbon dioxide is a powerful regulator of breathing (it acts on a different set of chemoreceptors, found in the brain) and if its concentration in the blood falls, breathing is (A) facilitated / inhibited. It is possible to demonstrate this for yourself. You will find you are able to hold your breath for longer if you breathe very rapidly for a short time beforehand. (Do not do this for more than a minute or you may become dizzy.) The reason is that breath-holding is terminated not by the demand for oxygen but rather by the (B) rising / falling carbon dioxide concentration in the blood. When this reaches a critical level it stimulates you to take a breath. Hyperventilation before holding your breath blows off carbon dioxide from the body and enables a longer period to go by before carbon dioxide builds up to a level sufficient to (C) stimulate / obstruct breathing. The opposing drives from oxygen and carbon dioxide explain why no change in breathing occurs at altitudes of less than 3000 metres.

\* chemoreceptor: 화학 수용체 \*\* hyperventilation: 과호흡 \*\*\* altitude: 해발

- |   | (A)         | (B)     | (C)       |
|---|-------------|---------|-----------|
| ① | facilitated | rising  | stimulate |
| ② | facilitated | falling | obstruct  |
| ③ | inhibited   | rising  | stimulate |
| ④ | inhibited   | rising  | obstruct  |
| ⑤ | inhibited   | falling | stimulate |

### Sentence Structure

- [The opposing drives from oxygen and carbon dioxide] **explain** [why no change in breathing occurs at altitudes of less than 3000 metres].

첫 번째 [ ]는 문장의 주어이고 이에 이어지는 문장의 술어동사는 explain이다. 두 번째 [ ]는 explain의 목적어 역할을 하는 명사절이다.

**Word Search** 주어진 문장에 들어갈 적절한 영어 단어를 본문에서 찾아 쓰시오. (필요시 형태를 바꿀 것)

1. An independent **r**\_\_\_\_\_ will be appointed for fair competition.
2. They **t**\_\_\_\_\_ his contract in December.
3. The government took steps to **s**\_\_\_\_\_ business development.

## Exercise 5~6

## 1지문 2문항

[5~6] 다음 글을 읽고, 물음에 답하십시오.

It is perhaps self-evident that the outworking of policy is seen in the exercise of power if it compels individuals to behave in a way which they would not have chosen to do. Policy can be used to highlight power relationships, but it can also allow for depersonalisation of power and decision-making: a leader could imply that while they don't really agree with a particular course of action, the policy (a) dictates it and therefore it must be done. In the same way policy can act as the source of authority such that hierarchy is unnecessary: a group of individuals may (b) resort to policy to guide their decision-making when there is no established authority figure to set their direction. Ultimately those who define policy exert power over those who (c) follow policy and, in education at least, it is rare that policy is determined collectively: at best, leaders are elected democratically so that they may set policy for the electorate. There is therefore an (d) inevitable reliance on a political elite, and a consequent hierarchy of power. A frequently seen example of policy as power in schools is uniform. It is for the 'governing board' of a school to determine if it has a uniform, and if so what it is, but parents and children have a duty to comply, and school staff have a duty to enforce it. Countless children will have discovered that they cannot appeal to the logic that inadequate uniform does not affect their learning, and nor can they resort to any individual to plead their case, for the power rests within the policy itself: it is (e) insufficient to say that you have to wear school uniforms because that is what the policy says.

\* hierarchy: 위계 \*\* electorate: 유권자 \*\*\* plead: 호소하다

## 5 윗글의 제목으로 가장 적절한 것은?

25007-0137

- ① Exploring Education Policy: Everyone Is the Victim
- ② Diversity Education: A Vital Inclusion in Educational Policy
- ③ Policy as Power: Understanding Its Implications in Education
- ④ Bridging Cultural Gaps Through Policy Engagement in Education
- ⑤ Resolving Negative Effects of Policy on Educational Decision-making

## 6 밑줄 친 (a)~(e) 중에서 문맥상 낱말의 쓰임이 적절하지 않은 것은?

25007-0138

- ① (a)
- ② (b)
- ③ (c)
- ④ (d)
- ⑤ (e)

### Sentence Structure

- **It** is perhaps self-evident [that the outworking of policy is seen in the exercise of power {if it compels individuals to behave in a way <which they would not have chosen to do>}].

It은 형식상의 주어이고 [ ]가 내용상의 주어이다. { }는 if가 이끄는 부사절이고, < >는 a way를 수식하는 관계절이다.

### Word Search

주어진 문장에 들어갈 적절한 영어 단어를 본문에서 찾아 쓰시오. (필요시 형태를 바꿀 것)

1. The United Nations has used its **a** \_\_\_\_\_ to restore peace in the area.
2. He has **e** \_\_\_\_\_ considerable influence on the scientific community.
3. The accident was the **i** \_\_\_\_\_ consequence of carelessness.

## Exercise 7 어휘

다음 글의 밑줄 친 부분 중, 문맥상 낱말의 쓰임이 적절하지 않은 것은?

25007-0139

Electric scooters are the latest vogue in urban transportation. They wait in clusters on the pavement, ready for hire by anyone with a smartphone and a credit card. Scooters are faster than walking, easier than cycling, and simpler than cars. They turn the urban landscape into a playground. Riding them is a carefree experience — but it is more ① restrained than it might seem. Every journey is tracked from start to finish. No matter how hard the throttle is pressed, the scooters will not go above a particular speed. They ② refuse to leave designated urban areas. And there is no haggling over the fare: an app charges a ③ precise sum depending on the length of the journey. None of this is inherently objectionable. But scooters do offer a helpful example of the paradox of digital technologies: they offer freedom, but only in exchange for some ④ maintenance of control. This is not a paradox that will ever be fully ⑤ resolved. The question will always be whether the balance between freedom and control is struck in the right place.

\* vogue: 유행 \*\* throttle: (자동차 등의 연료) 조절판 \*\*\* haggle: 흥정하다

### Sentence Structure

- [No matter how hard the throttle is pressed], the scooters will not go above a particular speed.  
[ ]는 양보의 부사절이고, No matter how는 However로 바꿔 쓸 수 있으며, ‘아무리 ~하더라도’의 의미이다.

**Word Search** 주어진 문장에 들어갈 적절한 영어 단어를 본문에서 찾아 쓰시오. (필요시 형태를 바꿀 것)

1. The city council is proposing a plan for a new u\_\_\_\_\_ park.
2. The parking lot is clearly d\_\_\_\_\_ for permit holders only.
3. The child possessed an i\_\_\_\_\_ curious nature, constantly asking questions.

## Exercise 8 문장 삽입

글의 흐름으로 보아, 주어진 문장이 들어가기에 가장 적절한 곳은?

25007-0140

It is more likely that language evolved in several stages in the same way, for instance, as our large brains did or our tool-making ability.

It is possible, in principle, that language suddenly appeared fully formed during human evolution without any gradual or intermediate forms. That notion, a linguistic Big Bang, has been championed by linguists such as Noam Chomsky. ( ① ) But it is extremely improbable, biologically speaking, that such a complex characteristic as our capacity for speech just popped up out of nowhere. ( ② ) This may have been a process similar to the one children go through, or the process may have been entirely different and involved intermediate forms. ( ③ ) But some form of evolution must have occurred on the journey from non-speaking ape to speaking humans. ( ④ ) At some point there must have been linguistic precursors, simpler forms of language. ( ⑤ ) There must also have been a protolanguage, the first one that could be called a language.

\* improbable: 가능성이 낮은, 일어날 듯하지 않은 \*\* precursor: 선행하는 형태

\*\*\* protolanguage: 조어(祖語), 공통 기어(基語)

### Sentence Structure

- That notion, [a linguistic Big Bang], **has been championed** by linguists [such as Noam Chomsky].  
 [ ]는 That notion과 동격 관계를 이루는 명사구이고, has been championed는 술부로서 현재완료형의 수동태이다. 두 번째 [ ]는 linguists를 수식한다.

**Word Search** 주어진 문장에 들어갈 적절한 영어 단어를 본문에서 찾아 쓰시오. (필요시 형태를 바꿀 것)

1. Over time, the language has e\_\_\_\_\_ to include new words and phrases.
2. To understand the poem's full meaning, you need to consider the l\_\_\_\_\_ devices the author uses.
3. This is an i\_\_\_\_\_ step before the final approval.

**Exercise 9** 요약문 완성

다음 글의 내용을 한 문장으로 요약하고자 한다. 빈칸 (A), (B)에 들어갈 말로 가장 적절한 것은?

25007-0141

In prior ages to the Digital Age, the power to create information remained primarily in the hands of designated authorities, be they the King or the *New York Times*. Today however, advances in information technology — specifically, computers and telecommunicators — have resulted in a situation where information can be created by anyone and can flow from *anyone to everyone else*. Take for example these astounding statistics: at the time of writing this paper, the number of websites currently online is over 1.5 billion, the number of active users on some of the biggest social media platforms is over two billion, and the number of Internet users is over four billion. More specific to consumer-created content, 400 hours of videos are uploaded every minute and searches of “how to” videos are growing 70% year over year on popular video sites. These numbers will likely increase by the time this manuscript goes to print. People today are not simply innocent consumers of information, but also providers of information through their own content creation, which is “the material people contribute to the online world.” Today, the production and distribution of information is a market in which nearly everyone can, and does, participate. \* astounding: 놀라운



In the Digital Age, advances in information technology have \_\_\_ (A) \_\_\_ the power to create and share content from designated authorities to individuals, resulting in a \_\_\_ (B) \_\_\_ information market where nearly everyone contributes.

- |              |       |                  |  |              |       |               |
|--------------|-------|------------------|--|--------------|-------|---------------|
| (A)          |       | (B)              |  | (A)          |       | (B)           |
| ① shifted    | ····· | closed           |  | ② shifted    | ····· | participatory |
| ③ retained   | ····· | competitive      |  | ④ maintained | ····· | privatized    |
| ⑤ maintained | ····· | consumer-created |  |              |       |               |

**Sentence Structure**

- In prior ages to the Digital Age, the power [to create information] remained primarily in the hands of designated authorities, [be they the King or the *New York Times*].  
 첫 번째 [ ]는 the power를 수식하는 to부정사구이다. 두 번째 [ ]는 whether they are the King or the *New York Times*의 의미이다.

**Word Search** 주어진 문장에 들어갈 적절한 영어 단어를 본문에서 찾아 쓰시오. (필요시 형태를 바꿀 것)

1. The crime rate in this area is below the national **s** \_\_\_\_\_.
2. The design was **i** \_\_\_\_\_ yet charming, full of simplicity and purity.
3. The **d** \_\_\_\_\_ of the new software update will begin next week.

## Exercise 10 어휘

다음 글의 밑줄 친 부분 중, 문맥상 낱말의 쓰임이 적절하지 않은 것은?

25007-0142

Scientific research is typically based on a cycle involving several distinct stages. The cycle typically starts with a collection of incidental observations and the formulation of a possible explanation for these observations. This explanation is known as a theory. Based on this theory, we can then make predictions about conditions that we have not yet ① observed. In other words, we can formulate specific hypotheses. Now, we can design an experiment that aims to disprove our theory: when the results of our experiment are consistent with the theory, we have no reason to suspect that anything is ② wrong with it. When the results are inconsistent, however, we will either have to ③ adjust our theory, or to reject it altogether. It is impossible to ‘prove’ a theory: as long as we find no conflicting evidence, the theory remains plausible. This does not exclude the possibility, however, that there might be future results that will ④ match. Although a theory becomes more plausible, the more results we find that are consistent with it, it remains the case that (at least in principle) a single experiment yielding conflicting results would be ⑤ sufficient to overthrow it.

\* plausible: 타당한 것 같은 \*\* overthrow: 뒤집어엎다

### Sentence Structure

- Scientific research is typically based on a cycle [involving several distinct stages].  
[ ]는 a cycle을 수식하는 분사구이다.

**Word Search** 주어진 문장에 들어갈 적절한 영어 단어를 본문에서 찾아 쓰시오. (필요시 형태를 바꿀 것)

1. Their paths crossed purely by i\_\_\_\_\_ chance at the coffee shop.
2. O\_\_\_\_\_ of the team’s interactions showed the importance of patience and open-mindedness.
3. I s\_\_\_\_\_ she knows more than she’s telling us.

## Exercise 11~12

## 1지문 2문항

[11~12] 다음 글을 읽고, 물음에 답하십시오.

One of the truths about writing in science is that it substantially limits the amount of insincere blather that can emanate from the mind of a student when he/she has absolutely no idea about a correct response. A student who does not have a basic understanding of scientific theories will have immense (a) difficulty in applying them. In responding to an authentic scientific problem through an essay, there is no way to “luck out” on a guess at the correct answer, there is no place to hide. In general, essays that require students to invoke relevant scientific principles and theories and to explore potential applications are more (b) genuine assessments of student knowledge than objective tests of short questions paired with possible answers already furnished.

Another (c) advantage of writing essays is that the teacher can get a sense of where student comprehension is strong and where understanding begins to break down. After all, writing is a form of concretized thought. Thus, when a student’s grasp of a concept begins to get off-track, it is only through those moments when thought is made (d) visible that a teacher is able to identify the problem and provide help. Writing provides the opportunity for the kind of intervention that can (e) worsen conceptual misunderstandings that can haunt a student for his entire academic career. Indeed, Heddy & Sinatra (2013) and Francek (2013) have found that one of the most difficult areas of teaching is trying to get students to unlearn a misconception.

\* blather: 허튼소리 \*\* emanate from: ~에서 나오다 \*\*\* invoke: (근거로 인물, 이론, 예 등을) 언급하다, 들다

## 11 윗글의 제목으로 가장 적절한 것은?

25007-0143

- ① The Benefits of Writing Essays in Science
- ② Essays in Science: Guesswork over Clarity
- ③ The Ugly Truth of Academic Scientific Writing
- ④ Unlearning Misconceptions Through Objective Tests
- ⑤ Enhancing Recall: How Writing Strengthens Knowledge

## 12 밑줄 친 (a)~(e) 중에서 문맥상 낱말의 쓰임이 적절하지 않은 것은?

25007-0144

- ① (a)
- ② (b)
- ③ (c)
- ④ (d)
- ⑤ (e)

### Sentence Structure

- Indeed, Heddy & Sinatra (2013) and Francek (2013) have found [that **one of the most difficult areas of teaching** is {trying to get students to unlearn a misconception}].

[ ]는 found의 목적어 역할을 하는 명사절이다. 「one of the 최상급+복수 명사」는 '가장 ~한 것 중 하나'의 의미이다. { }는 is의 주격 보어로 쓰인 명사구이다.

### Word Search

주어진 문장에 들어갈 적절한 영어 단어를 본문에서 찾아 쓰시오. (필요시 형태를 바꿀 것)

1. The firefighters battled the **i**\_\_\_\_\_ forest fire for days, facing danger.
2. While interesting, the information about the celebrity's vacation was not entirely **r**\_\_\_\_\_ to the topic at hand.
3. The teacher's timely **i**\_\_\_\_\_ prevented a fight from breaking out between the two students.

## 01 다음 글의 목적으로 가장 적절한 것은?

25007-0145

Dear Dr. Stevens,

For the past four years, volunteering at the Langford Science Museum has been a source of pride since my retirement as a university professor. However, recent changes in volunteer schedule management are proving increasingly challenging for me and many others to sustain our commitment. Previously, volunteers were asked to sign up for available slots on the schedule. This worked very well for all of us because it allowed the flexibility to fit our volunteer time with various other demands on our time. In the last six weeks, though, the new manager of volunteer services has begun assigning us to volunteer schedules without consulting us, causing a great deal of upset among the volunteers and resulting in numerous cancellations of shifts. As unpaid volunteers, we value our autonomy and should not be treated like salaried employees whose working hours can be assigned by management. I hope you can address this problem before it becomes too great to solve.

Sincerely,  
Kate Greenbaum

\* autonomy: 자율성

- ① 박물관 편의 시설의 확충을 요청하려고
- ② 박물관 직원의 친절한 안내에 감사하려고
- ③ 과학 박람회 자원봉사 활동 참여를 권유하려고
- ④ 자원봉사자 선정 기준에 대해 이의를 제기하려고
- ⑤ 변경된 자원봉사 일정 관리 방식에 대해 항의하려고

## 02 다음 글에 드러난 'I'의 심경 변화로 가장 적절한 것은?

25007-0146

A powerful earthquake struck our home at midnight, jolting me awake and nearly throwing me out of my bed. My instant response was to run and get my son, Dustin, who was in the room at the other end of our house. Everything was dark after the power went out. I ran across the house in total darkness, my hands outstretched, blindly feeling for walls and furniture to guide me towards Dustin's bedroom. A violent aftershock knocked me to my knees, but I couldn't stop. I had to get to my son, no matter what. Then, the shaking stopped, and everything became quiet as I peered into my son's bedroom. By now accustomed to the darkness, I could make out that Dustin's bookcases had fallen into the center of the room, narrowly missing his bed. Crawling over the debris, I finally reached Dustin. He was shaking with fear, but was huddling safely under the covers. I hugged Dustin tight and breathed a sigh of relief. In that moment, nothing else mattered but the fact that my son was safe.

\* jolt: 갑자기 거칠게 흔들다 \*\* debris: 잔해 \*\*\* huddle: 웅크리고 있다

- ① surprised → curious
- ② ashamed → grateful
- ③ frustrated → confident
- ④ desperate → relieved
- ⑤ scared → confused

## 03 다음 글에서 필자가 주장하는 바로 가장 적절한 것은?

25007-0147

Good intuition is the first requirement for designing meaningful ecological studies. The best way to develop that intuition is by observing organisms in the field. Sadly, few of us “have the time” to just observe nature. Graduate committees and tenure reviewers are not likely to recommend investing precious time in this way. However, observations are absolutely essential for you to generate working hypotheses that are grounded in reality. So, carve out some time to get to know your organisms. If you are too busy with classes and other responsibilities, then reserve two days before you start your experiments to observe your ecological system with no manipulations (or preconceived notions). It’s often fun to do this with a lab mate or colleague. The opposite can work well too: consider spending a whole day with no other people or distractions around, just looking at your system.

\* tenure: (교수의) 종신(終身) 재직권 \*\* carve out: ~을 할애하다

- ① 생태계 현장 연구에 착수하기 전에 가설의 타당성을 사전에 점검하라.
- ② 생태계 연구에 필요한 영감을 얻기 위해 다양한 자료를 폭넓게 탐독하라.
- ③ 생물 관찰 여건이 조성되지 않을 경우를 대비하여 대안적인 계획을 마련하라.
- ④ 관찰 연구를 설계할 때는 연구 대상 생물에게 장기적으로 미칠 영향을 고려하라.
- ⑤ 생태 연구 설계에 필요한 직관 계발을 위해 현장에서 생태계를 있는 그대로 관찰하라.

04

밑줄 친 this is like saying you should carry an umbrella in Spain because it is going to rain in Vietnam이 다음 글에서 의미하는 바로 가장 적절한 것은?

25007-0148

We are getting better at understanding the influence of humans on the global climate system. As the planet gets warmer, high latitudes will warm faster than the tropics. The Mediterranean will become drier, and the tropics will be wetter. But this is like saying you should carry an umbrella in Spain because it is going to rain in Vietnam. To plan for and adapt effectively to climate change, we need information about the future climate at much finer scales than general circulation models (GCMs) can provide. To decide whether to put up a dike, move some houses, switch crops, or buy insurance, we need data at scales of less than 100 kilometers. One approach is to embed a finer-scale model of a particular area of interest into a larger-scale GCM. No region is isolated from the rest of the planet, so the GCM part of the model can keep track of what is going on globally and exchange information with the finer-scale regional climate model.

\* general circulation model: (대기학) 대기 대순환 모델 \*\* dike: 제방 \*\*\* embed: 끼워 넣다

- ① It is hard to reach a consensus on how to tackle the climate crisis.
- ② What happens in the climate of one region could affect that of another.
- ③ Climate actions are sure to fail without the participation of major polluters.
- ④ We need to stop measuring the effects of climate change by using an outdated scale.
- ⑤ Relying solely on global-scale predictions ineffectively addresses local climate change issues.

## 05 다음 글의 요지로 가장 적절한 것은?

25007-0149

The bear not only knows where and when to find food, he also knows when to retreat to his den to ride out a challenging time. Like the bear, we sometimes feel a need to retreat from the world, particularly after periods of stress. When we feel this bear-like urge to carve out restorative time to “hibernate,” we should think of it as the sensible impulse of our inner bear. We might consider withdrawing from some social activities to take stock of our lives, start a creative project, plan a trip, or plant seeds of thought that will hopefully spring up and come to fruition in the future. However, we also need to remember that bears come out of their dens once spring arrives. Spending too much time in isolation can deprive us of connection with and inspiration from the outside world. It’s best to balance the urge to retreat for restoration with the opportunity to be revitalized by all that the world has to offer.

\* den: (야생 동물이 사는) 굴 \*\* hibernate: 동면하다

- ① 인생의 겨울을 대비해 충분한 에너지를 비축하는 것이 필요하다.
- ② 변화에 대해 한결같은 자세로 대처하는 것이 스트레스를 방지한다.
- ③ 삶을 되돌아보는 시기에 이르러 새로운 인생을 계획하는 것은 어렵다.
- ④ 인생에서 인내와 노력의 시간이 반드시 결실을 가져오는 것은 아니다.
- ⑤ 휴식을 통한 재충전과 활력을 주는 사회 활동 참여 사이의 균형이 중요하다.

## 06 다음 글의 주제로 가장 적절한 것은?

25007-0150

Plants are not set pieces in our human drama, they are characters with distinct experiences and needs. Like us, they are capable of affection, care, and suffering. While we can (and do) dismiss the moral importance of plant experiences, to pretend that they don't exist is a very dangerous form of disregard. Our cold, utilitarian approach to reducing climate change has so far been largely ineffectual. To bring real change, we need to learn to *see* plants as independent, intrinsically valuable, *sentient* beings — not mere tools for our own human flourishing. Our welfare is deeply dependent upon the welfare of plants, and the best way for us to make *sense* of this is by reminding ourselves that they are *persons*. They have just as much of a right to clean water, healthy soil, and a liveable atmosphere as the rest of us, and this needs to be remembered when we consider the ethical dimensions of climate change.

\* sentient: 지각력이 있는

- ① destructive consequences of non-native plants on regional ecosystems
- ② the reduction of plant species diversity stemming from climate change
- ③ the ecology of plants that provide a reference point to human ethical life
- ④ ethical lessons that humans can learn from plants for restoring human nature
- ⑤ the need to recognize plants as conscious beings in addressing climate change

## 07 다음 글의 제목으로 가장 적절한 것은?

25007-0151

Whereas contemporary cuisines represent a true blending of influences that developed all over the world, contemporary sports do not. In fact, global sports spread more like the bubonic plague than the burrito. They are global phenomena that emerged almost exclusively from Western civilization — from European nations and European settler societies — and spread to other parts of the world. Take, for instance, soccer (association football). Before European contact, ball games that limited or barred the use of the hands flourished in Mesoamerica. Today, *fútbol* ignites the passions of millions of Mexicans. Estadio Azteca has been filled to overflowing for two World Cup finals (1970 and 1986) and a multitude of other international matches. You might easily conclude that *fútbol* fused Mesoamerican and European sporting pastimes, much like pizza and pasta fused Old World and New World food. It did not.

\* bubonic plague: 흑사병(黑死病) \*\* *fútbol*: football에 해당하는 스페인어의 단어

- ① New Taste, the Easternization of the West
- ② Is Europe Truly the Birthplace of Football?
- ③ The Similarities Between Cuisines and Sports
- ④ Why Sports Spread More Easily than Cuisines
- ⑤ Contemporary Sports: Western Roots and Global Expansion

## 08 다음 도표의 내용과 일치하지 않는 것은?

25007-0152

## How Student-Teacher Ratios Vary Across the Globe

Average number of students per teacher in public elementary and secondary schools in 2019

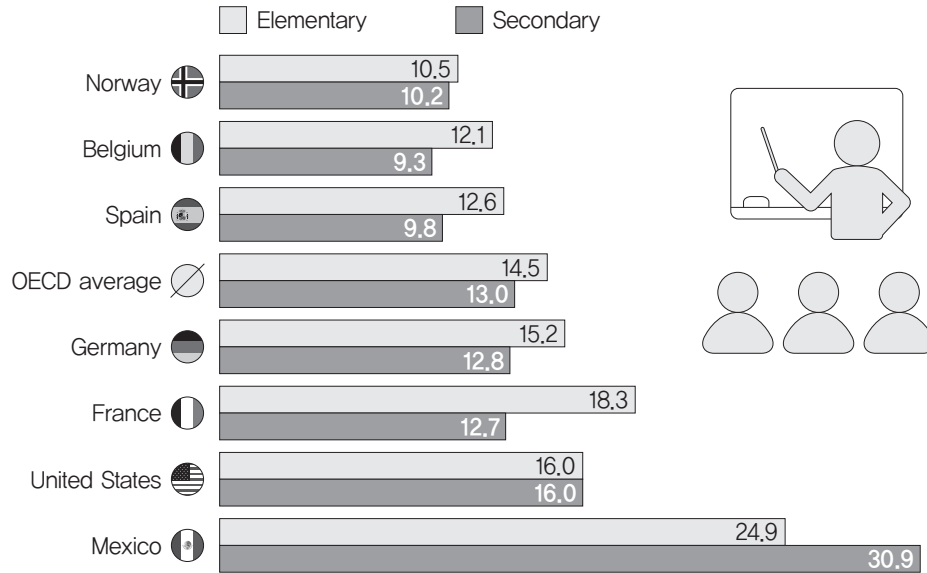

\* in selected OECD countries

Source: OECD

The chart above shows the differences among countries in the average number of students per teacher in public elementary and secondary schools for seven OECD countries in 2019. ① Norway had the lowest average number of students per teacher in elementary schools, while Belgium had the lowest in secondary schools. ② In Spain, the average number of students per teacher was 0.5 higher than in Belgium for both elementary and secondary schools. ③ France exhibited the second largest difference in the average number of students per teacher between elementary and secondary schools, with more than five additional students per teacher in secondary schools. ④ The United States uniquely recorded an equal student-to-teacher ratio between elementary and secondary schools. ⑤ Meanwhile, Mexico was the only country among those listed in the chart where the student-to-teacher ratio in secondary schools was higher than in elementary schools.

09

Helen Moore Sewell에 관한 다음 글의 내용과 일치하지 않는 것은?

25007-0153

Helen Moore Sewell was an American artist and author of children's books who was known for her illustrations. Sewell began drawing at an early age. At the age of 12, she became the youngest person ever to attend the Pratt Institute, which was especially renowned for art and design. She also studied under the Ukrainian American artist Alexander Archipenko, who dramatically influenced her style. Sewell's early work was as both an author and an illustrator. In 1924, she illustrated her first book, Susanne K. Langer's *The Cruise of the Little Dipper, and Other Fairy Tales*. She illustrated her own book, *ABC for Everyday*, in 1930 and a year later collaborated with her younger sister on *Building a House in Sweden*. She also illustrated classic works, including those by American poet Emily Dickinson and British authors like Jane Austen. During her career, Sewell illustrated more than 50 books. She won a Caldecott Honor in 1955 for her illustrations in *The Thanksgiving Story* by American author Alice Dalgliesh.

\* renowned: 유명한, 명성 있는

- ① Pratt Institute를 다닌 사람 중 역대 최연소자였다.
- ② 우크라이나계 미국인 화가 Alexander Archipenko 밑에서 공부했다.
- ③ 1930년에 자신의 여동생과 함께 *Building a House in Sweden*을 공동으로 작업했다.
- ④ 미국 시인이나 영국 작가들의 고전 작품에 삽화를 그렸다.
- ⑤ 경력 기간 동안 50권이 넘는 책에 삽화를 그렸다.

## 10 Fun Unplugged Game Night에 관한 다음 안내문의 내용과 일치하지 않는 것은?

25007-0154

### Fun Unplugged Game Night

The Town of Windsor Youth Service Center presents Fun Unplugged Game Night. Come out to play board games, card games, and dice games with your friends and family members!

**When:** Friday, April 18 from 6:00 P.M. to 8:00 P.M.

**Where:** Windsor Youth Service Center

**Who:** Open to all Windsor residents! Children under 12 must be accompanied by an adult.

**Details:**

- Free admission. (Drinks and snacks are available at no cost.)
- Games are provided, but you are also welcome to bring your own classic or non-electronic games.
- Seating is limited to 100 people.
- Pre-registration is required as we cannot accommodate walk-ins.
- To reserve your seat, contact Sarah Bunyan at 860-627-1482.

For more information, please email us at [unpluggn@townwindsorgu.co.uk](mailto:unpluggn@townwindsorgu.co.uk).

\* dice: 주사위

- ① 금요일 저녁 2시간 동안 진행된다.
- ② 12세 미만은 반드시 성인과 동행해야 한다.
- ③ 음료와 간식이 무료로 제공된다.
- ④ 자신이 가지고 있는 고전 또는 비전자식 게임을 가져와도 된다.
- ⑤ 사전 등록 없이 현장에서 바로 참여가 가능하다.

## 11

GivingFriday Event에 관한 다음 안내문의 내용과 일치하는 것은?

25007-0155

**GivingFriday Event**

GivingFriday is an annual global event dedicated to promoting the spirit of giving. This event takes place every year on the Friday after American Thanksgiving. It lasts for 24 hours starting at midnight local time. It encourages nonprofit organizations to engage in activities that foster sharing and a sense of community.

**Registration:**

- There is no formal registration process to participate in this event.
- Any nonprofit organization is welcome to join.

**Donations:**

- The GivingFriday website does not accept or distribute donations directly.
- Nonprofit organizations must accept donations only through their own websites.

**Cost:** Participation in the event is free.

**Ways to Participate:** Organizations can join by hosting food drives, recruiting volunteers, or sharing their actions on social media using the hashtag #GivingFriday.

※ Free resources are available on the GivingFriday website.

- ① 미국 추수감사절 바로 직전 금요일에 진행된다.
- ② 현지 시간으로 정오부터 24시간 동안 진행된다.
- ③ 공식적인 등록 절차가 필요하다.
- ④ 기부하는 금요일 웹사이트를 통해 직접 기부금을 받거나 배분할 수 있다.
- ⑤ 자원봉사자를 모집하는 방식으로 참여할 수 있다.

## 12 다음 글의 밑줄 친 부분 중, 어법상 틀린 것은?

25007-0156

While new media allow us to do new things, make new kinds of meanings, and think, relate to others and enact our own identities in new ways, they also invariably introduce limitations on what we can do and mean, how we can think and relate, and who we can 'be' when we are using ① them. Television news, for example, ② allows for a vivid and dramatic presentation of a story, but may be less suitable than a newspaper or magazine for lengthy and probing analysis. Social networking sites make it easier for us to stay ③ connected to our friends, but make it more difficult to maintain our privacy (especially from advertisers). Caller identification, which is standard on most mobile phones, makes it easier for us to screen our calls, but it also makes it easier for calls that we make ④ is screened by others. Often the constraints of new technologies are less visible to us than their affordances. We tend to be so focused on the new things we *can* do with a new tool ⑤ that we don't pay attention to the things we *cannot* do with it.

\* probing: 면밀히 살피는 \*\* affordance: 행동 유도성

### 13 다음 글의 밑줄 친 부분 중, 문맥상 낱말의 쓰임이 적절하지 않은 것은?

25007-0157

When given many chances, chance will tend to distribute random differences fairly equally. However, when given few chances, it may distribute random differences very unequally. Thus, if you assigned each individual to a group by flipping a coin and you had many participants, chance would do a ① good job of making your groups equivalent. Conversely, if you had few participants, chance would probably do a poor job of ② balancing the effects of individual differences between groups. Indeed, with too few participants, chance has no chance. For example, if you had four people in your study and only one of those was violent, flipping a coin could not give you ③ equal groups. Even if you had eight participants, four of whom were violent, flipping a coin might result in all four violent individuals ending up in the same group. Why? Because, in the short run, chance can be unpredictable. For instance, it is not that ④ usual to get four “heads” in a row. To appreciate that chance can be unpredictable in the short run but ⑤ dependable in the long run, realize that although a casino may lose several bets in a row, the casino always wins in the end.

\* equivalent: 동등한

## 14 다음 빈칸에 들어갈 말로 가장 적절한 것은?

25007-0158

\_\_\_\_\_ of predator recognition makes functional sense because individuals that must experience predators for themselves to learn they are dangerous may not survive those experiences. The best-analyzed example involves monkeys' fear of snakes. Monkeys reared in captivity do not exhibit fear the first time they encounter live or toy snakes. If they watch another monkey behaving fearfully toward a snake, they later do the same themselves. During the learning trial the naive observer exhibits behavior like the model's (in this case responses such as withdrawal, vocalization, and piloerection). If naive monkeys observe a model behaving fearfully toward a snake and neutrally toward another object like a flower, they acquire the same discrimination. For example, if they are later offered raisins that are out of reach beyond a flower or a snake, they reach quickly over the flower but refuse to reach over the snake.

\* piloerection: 털 세우기 \*\* raisin: 건포도

- ① The genetic basis
- ② Social transmission
- ③ Misleading guidance
- ④ Immediate comprehension
- ⑤ The unconscious inhibition

## 15 다음 빈칸에 들어갈 말로 가장 적절한 것은?

25007-0159

In the 1880s, a German psychologist named Hermann Ebbinghaus shut himself up in a room in Paris to test how memory works. He forced himself to learn, review, and recall nonsense words on a specific, timed schedule. What Ebbinghaus discovered was that the rate of forgetting was predictable. He discovered a pattern of exactly how long it took to forget. If he reminded himself of one of his nonsense words just before he knew he was about to forget it — but no sooner — he could save himself hours of studying but still recall the information correctly. The trick was knowing \_\_\_\_\_ . Ebbinghaus’s memorization technique became known as spaced repetition. Essentially, it was the most highly specific, scientifically based study schedule you could dream of. Over a hundred years later, specially designed computer programs made following a modified version of Ebbinghaus’s schedules feasible.

\* feasible: 실현 가능한

- ① how to make connections
- ② how he could ask meaningful questions
- ③ what the big picture was, not the details
- ④ which sources of motivation to rely on
- ⑤ when he was about to forget it

## 16 다음 빈칸에 들어갈 말로 가장 적절한 것은?

25007-0160

Linguist Philip Lieberman argues that human ancestors (e.g., *Homo erectus*) had the ability to speak, although their speech would not have been as refined as modern humans' speech. This conclusion is based on reasoning about why the human vocal tract has the shape it does. Lieberman notes that to produce vowel sounds such as /i/ (as in *meet*) and /u/ (as in *you*), the space above the larynx in the throat has to be about the same length as the horizontal space between the top of the throat and the mouth opening. For natural selection to produce and maintain this arrangement, Lieberman argues, some basic speech abilities must have been present beforehand. Natural selection could then have favored individuals who had physical characteristics that \_\_\_\_\_. Unless some basic speech abilities were present prior to the appearance of *Homo sapiens*, a lowered larynx, and the accompanying ability to produce more vowel sounds, would have to be the result of a massive and incredibly lucky mutation, rather than gradual evolution by natural selection.

\* vocal tract: 성도(구강, 비강 등을 포함하여 말을 할 때 공기가 통과하는 후두 위의 통로)

\*\* larynx: 후두 \*\*\* mutation: 돌연변이

- ① allowed them to produce a wider range of vowel sounds
- ② restricted the use of vowels to refine their speech abilities
- ③ improved their ability to reproduce and pass on their genes
- ④ enhanced their ability to communicate nonverbally for cooperation
- ⑤ made them more resistant to mutations affecting their speech abilities

## 17 다음 빈칸에 들어갈 말로 가장 적절한 것은?

25007-0161

What is the meaning of a concept and how does it contribute to the meaning of a sentence? Philosophers have been particularly vexed by this question and have developed a range of possible answers to it. On the one hand, the meaning of a concept seems to derive from the meaning of other concepts, as when a child is told the meaning of *sprint* by saying it is a kind of fast running. On the other hand, the meaning of a concept is connected to observations of things in the world, as when the child actually sees someone sprinting. A concept's meaning is normally not given by definition in terms of other concepts, since successful exact definitions are rare. Nor is meaning exhausted by a set of examples, as if one identified the concept of *dog* with a set of dogs. A theory of meaning of the concepts must therefore \_\_\_\_\_ . Both aspects are necessary in order for us to understand how concepts underlie our ability to use language.

\* vex: 고충을 느끼게 하다

- ① reflect both the linguistic ability of the language users and their cognitive process
- ② include an account of how concepts are related both to each other and to the world
- ③ account for the emotional part of the concepts as well as their practical applications
- ④ cover not only general terms but also diverse linguistic expressions from various cultures
- ⑤ address the inherent vagueness of concepts and the role of the interpretation by individuals

## 18 다음 글에서 전체 흐름과 관계 없는 문장은?

25007-0162

In local communities where they know each other well, speakers and listeners are able, for the most part, to draw on knowledge of overlapping language habits to converse or argue about moral and political issues. ① This may still be the case, to some extent, when communities of speakers who engage regularly with one another in practical activities do not all speak the same languages, or speak them equally fluently. ② Sometimes, however, potential parties to a verbal exchange find themselves sharing little more than physical proximity to one another. ③ The fact that physical contact has such strong cultural meanings shows that it's a vital element of non-verbal communication around the world. ④ Such situations arise when members of communities with radically different language traditions and no history of previous contact with one another come face to face and are forced to communicate. ⑤ There is no way to predict the outcome of such enforced contact on either speech community, yet from these new shared experiences, new forms of practice, including a new form of language — pidgin — may develop.

\* proximity: 근접성 \*\* radically: 근본적으로 \*\*\* pidgin: 피진어(의사소통되지 않는 사람들 사이에 형성된 언어)

## 19 주어진 글 다음에 이어질 글의 순서로 가장 적절한 것은?

25007-0163

Machines have aided the scientific process for decades. Will they be able to take the next step, and help us automatically identify promising new discoveries and technologies?

- (A) But, humans are still responsible for forming hypotheses, designing experiments, and drawing conclusions. What if a machine could be responsible for the entire scientific process — formulating a hypothesis, designing and running the experiment, analyzing data, and deciding which experiment to run next — all without human intervention?
- (B) If so, it could drastically accelerate the advancement of science. Indeed, scientists have been relying on robot-driven laboratory instruments to screen for drugs and to sequence genomes.
- (C) The idea may sound like a plot from a futuristic sci-fi novel, but that sci-fi scenario has, in fact, already happened. Indeed, back in 2009, a robotic system made a new scientific discovery with virtually no human intellectual input.

\* genome: 게놈(세포나 생명체의 유전자 총체)

① (A) - (C) - (B)

② (B) - (A) - (C)

③ (B) - (C) - (A)

④ (C) - (A) - (B)

⑤ (C) - (B) - (A)

## 20 주어진 글 다음에 이어질 글의 순서로 가장 적절한 것은?

25007-0164

Solutions we choose to solve environmental problems depend upon how we value people and the environment.

- (A) This choice will reduce damage from flooding while providing habitat for a variety of animals including raccoons, foxes, beavers, and muskrats that use the stream environment; resident and migratory birds that nest, feed, and rest close to a river; and a variety of fish that live in the river system. We will also be more comfortable when interacting with the river. That is why river parks are so popular.
- (B) For example, if we believe that human population growth is a problem, then conscious decisions to reduce human population growth reflect a value decision that we as a society choose to endorse and implement. As another example, consider flooding of small urban streams. Flooding is a hazard experienced by many communities.
- (C) The study of rivers and their natural processes leads to a number of potential solutions for a given flood hazard. We may choose to place the stream in a concrete box — a remedy that can significantly reduce the flood hazard. Alternatively, we may choose to restore our urban streams and their floodplains, the flat land adjacent to the river that periodically floods, as greenbelts.

\* muskrat: 사향쥐 \*\* endorse: 승인하다 \*\*\* adjacent to: ~에 인접한

- ① (A) - (C) - (B)                      ② (B) - (A) - (C)                      ③ (B) - (C) - (A)  
 ④ (C) - (A) - (B)                      ⑤ (C) - (B) - (A)

## 21 글의 흐름으로 보아, 주어진 문장이 들어가기에 가장 적절한 곳은?

25007-0165

But not all exercise in the ancient world was combat related.

The generalization, that adult exercise is modern, is kind of obvious. Early farmers had to toil as hard as if not harder than hunter-gatherers, and for the last few thousand years farmers primarily exercised, often through sports, to prepare for fighting. ( ① ) Ancient texts like *The Iliad*, paintings from pharaonic Egypt, and Mesopotamian carvings testify that sports like wrestling, sprinting, and javelin throwing helped would-be warriors keep fit and hone combat skills. ( ② ) If you were wealthy enough to attend one of the great Athenian schools of philosophy, you would have been advised to exercise as part of your physical education. ( ③ ) Philosophers like Plato, Socrates, and Zeno of Citium preached that to live the best possible life, one should exercise not only one's mind but also one's body. ( ④ ) This idea is not just Western. ( ⑤ ) Confucius and other prominent Chinese philosophers also taught that exercise was equally essential for physical and mental health and encouraged regular gymnastics and martial arts.

\* toil: 힘들게 일하다 \*\* javelin: 창 \*\*\* hone: 연마하다

## 22

글의 흐름으로 보아, 주어진 문장이 들어가기에 가장 적절한 곳은?

25007-0166

In much the same way, some scholars argue, the future somehow “grows” out of conditions in the past and the present.

There is considerable debate about whether or not the future really exists and, if it does, where one could find it. ( ① ) Let us leave aside the realm of science fiction, where time travelers are able actually to experience the future “before it happens,” and concentrate on those visions in which the future is somehow knowable because it is connected to the past and the present. ( ② ) Some scholars see time in much the same way as biologists see living organisms. ( ③ ) If biologists know the genetic material of an organism and the conditions in which it lives (its nutrition, for example), and they know the laws that govern its development, they can predict how the mature organism will look and behave. ( ④ ) There is a direct and almost physical connection between past and future. ( ⑤ ) If one perceives the present and the past correctly, and if one also knows the laws that govern development or growth, then one can forecast fairly accurately what the future will be like.

\* realm: 영역

23

다음 글의 내용을 한 문장으로 요약하고자 한다. 빈칸 (A), (B)에 들어갈 말로 가장 적절한 것은?

25007-0167

Emotions play powerful roles in health-related behaviors, motivating both current behavior and efforts to change future behavior, altering the way we process health-related information and shaping health-related judgments and decisions. After many years in which theoretical models of health behavior — and intervention efforts based on these models — emphasized knowledge, beliefs, attitudes, and self-efficacy, emotions are increasingly recognized as playing a crucial role. However, attempts to add an emotional component to behavior change interventions have focused almost exclusively on fear. Public service announcements (PSAs) promoting behavior change (e.g., smoking cessation, healthy diet) routinely present frightening facts and images in an effort to scare the viewer into adopting a healthier lifestyle. Although fear appeals are highly memorable, they are effective in promoting behavior change only if they also boost self-efficacy so viewers believe they are able to do whatever is needed to avoid the dangerous outcome; otherwise, they simply tune out the message. Because a typical viewer has already tried several times to make the change in question and failed, this is a substantial challenge.

\* self-efficacy: 자기 효능감 \*\* cessation: 중지



Emotions have played a vital role in \_\_\_ (A) \_\_\_ health-related behaviors, but \_\_\_ (B) \_\_\_ fear may not be effective without increasing self-efficacy.

- | (A)           | ..... | (B)          |
|---------------|-------|--------------|
| ① steering    | ..... | evoking      |
| ② steering    | ..... | neutralizing |
| ③ impacting   | ..... | conquering   |
| ④ restraining | ..... | diminishing  |
| ⑤ restraining | ..... | addressing   |

[24~25] 다음 글을 읽고, 물음에 답하시오.

Education has always emphasized rules and logical thinking. Step-by-step learning proceeds in a predetermined direction (vertical thinking). Researchers have viewed creativity as a mysterious ability that can be fostered but not taught. Psychological studies have found that the natural creativity of children often declines after a couple of years in school.

According to a psychologist Edward de Bono, creativity requires the (a) restructuring of deep-rooted patterns. The ability, whether innate or developed, to go beyond the limitations of previous patterns is integral to that process. Lateral thinking is needed, the fundamental principle of which is that any particular point of view is but one of many possibilities. There are just as many descriptions of a phenomenon as there are perspectives. Lateral thinking seeks (b) alternative patterns instead of simply building on existing models.

Vertical thinking is a gradually increasing process, whereas lateral thinking permits significant leaps. The individual steps involved in lateral thinking need not be correct as long as the ultimate conclusion solves the problem. Instead of constantly evaluating and accepting that which appears to be correct at the moment, an assessment is (c) postponed. Once a certain point has been reached, it is often possible to retrace a logical path to the starting point. Once that has been accomplished, the direction and order of the various steps are (d) likely to matter very much. Lateral thinking is like building a vault or a bridge with scaffolding that is torn down once construction has been completed. The various parts of the bridge do not have to stand on their own during each phase of the project. But once the keystone has been laid, the entire structure must be (e) self-supporting.

\* lateral: 수평적인, 측면의 \*\* vault: 아치형 천장 \*\*\* scaffolding: (공사장의) 비계, 발판

**24** 윗글의 제목으로 가장 적절한 것은?

25007-0168

- ① Embracing Chaos: The Path to Clearer Thinking
- ② Unveiling the Illusions of Creative Problem-solving
- ③ How to Improve Your Lateral Thinking Skills for Work
- ④ From Lateral to Vertical: Evolving Problem-solving Strategies
- ⑤ Lateral Thinking: Unlocking Creativity Through Significant Leaps

**25** 밑줄 친 (a)~(e) 중에서 문맥상 낱말의 쓰임이 적절하지 않은 것은?

25007-0169

- ① (a)
- ② (b)
- ③ (c)
- ④ (d)
- ⑤ (e)

[26~28] 다음 글을 읽고, 물음에 답하십시오.

(A)

My son, David, participated in Scouts when he was younger and learned everything from how to build a fire to how to help those in our community. To say that I'm proud of him would be an understatement, but there was one specific time I remember that caused my chest to swell with pride. We had an elderly neighbor next door, Albert, who had been alone for several years. His wife had passed away, and (a) he was confined to a wheelchair.

(B)

I smiled at David's sense of duty and kindness. I watched from the window as David gathered the branches into a pile and cleaned up the mess on the lawn. Then, (b) he knocked on Albert's door. I couldn't hear what he said, but I watched in silence as he ran back to our house, grabbed two plates and the stack of pancakes that was waiting for him, and returned to Albert's. The two of them sat on the porch and chatted as they shared breakfast. After that, they became good friends.

\* porch: (건물 입구에 지붕이 얹혀 있는) 현관

(C)

Some years later, Albert passed away. David was heartbroken and emotional over the loss of his friend. Then one day, Albert's lawyer visited us and handed us an envelope. In it, there was a large sum of money in the form of a check. Albert had saved money for David's first year of college! And there was a letter — the last letter (c) he wrote to David. "The world is a better place because you're in it. Keep spreading kindness, and continue to do good. We need people like you now more than ever. Thank you for being a friend to a lonely old man."

(D)

One evening, there was an awful thunderstorm. When we woke up the next morning, David noticed that Albert's house had been hit particularly hard. Branches were scattered across the grass, and things that had been on the porch were scattered all over (d) his front lawn. "Mom, I've got to do something to help Mr. Albert," David said as I made pancakes. "I think I'll wait to have breakfast until after I'm finished helping (e) him." And he ran into the garage to get his tools.

**26** 주어진 글 (A)에 이어질 내용을 순서에 맞게 배열한 것으로 가장 적절한 것은?

25007-0170

- ① (B) - (D) - (C)                      ② (C) - (B) - (D)                      ③ (C) - (D) - (B)  
 ④ (D) - (B) - (C)                      ⑤ (D) - (C) - (B)

**27** 밑줄 친 (a)~(e) 중에서 가리키는 대상이 나머지 넷과 다른 것은?

25007-0171

- ① (a)                      ② (b)                      ③ (c)                      ④ (d)                      ⑤ (e)

**28** 밑글에 관한 내용으로 적절하지 않은 것은?

25007-0172

- ① Albert는 아내와 사별하고 혼자 살고 있었다.  
 ② I는 David가 나뭇가지를 모아서 쌓는 것을 창문으로 지켜보았다.  
 ③ David는 집에 돌아와 팬케이크를 먹은 후에 다시 Albert의 집으로 갔다.  
 ④ Albert의 변호사가 건넌 봉투 안에는 거액의 수표가 들어 있었다.  
 ⑤ Albert의 집은 특히 심하게 뇌우의 타격을 입었다.

## 01 다음 글의 목적으로 가장 적절한 것은?

25007-0173

Dear Ruth Allen,

I hope this message finds you well. My name is Orville Rivera and I recently joined the team to work on various corporate strategy initiatives. One of my current responsibilities is to lead the quality systems project. As I embark on this task, I'm in the initial stages of gathering information about the existing systems and understanding the requirements from the users' perspective. Given your role and expertise, I believe your insights would be invaluable to ensure the success of this endeavor. I would greatly appreciate the opportunity to discuss the project with you in more detail, including current workflows, user expectations, and any other insights you may have. Would it be possible for us to schedule a meeting later this week at your convenience? Thank you for considering my request, Ruth.

Best regards,  
Orville Rivera

\* initiative: (새로운 중요) 기획[계획] \*\* embark on: ~을 시작하다

- ① 새롭게 바뀐 기업 전략을 소개하려고
- ② 시스템 관리 분야 전문가를 추천하려고
- ③ 전략 회의 날짜가 변경되었음을 알리려고
- ④ 프로젝트 신청을 위한 개인 정보 제공 동의를 구하려고
- ⑤ 프로젝트를 함께 논의하기 위해 만나 줄 것을 요청하려고

## 02 다음 글에 드러난 'I'의 심경 변화로 가장 적절한 것은?

25007-0174

The day came for the operation, and we arrived at the hospital early in the morning. Sal was taken into surgery, and I went down to the chapel to pray. Tears were streaming down my face. I prayed like I had never prayed before. I just wanted to see this man whom I loved so much come out of the surgery and be free of this threatening disease. I went back up to the waiting room and sat there with our daughter for what seemed like an eternity. The doctor finally came into the room. All I could see was his eyes. He said that the surgery went well, and they removed any possible lingering cancer cells. I started to cry again, but with joy this time that this man I loved would be by my side again, healthy and smiling and looking forward to all the beautiful things that life had in store for us.

\* chapel: 예배당 \*\* eternity: 영원 \*\*\* lingering: 계속 남아 있는

- ① bored → surprised
- ② anxious → relieved
- ③ doubtful → confident
- ④ grateful → frightened
- ⑤ thrilled → disappointed

## 03 다음 글에서 필자가 주장하는 바로 가장 적절한 것은?

25007-0175

Avoiding scientific jargon is not as hard as it seems, as articles written for the public, for government and even industry usually focus on the application of the science, not on the science itself. It is nearly always possible to describe the application of science in plain language. Nevertheless, scientists sometimes complain that the translation of science into plain language ‘devalues’ it or ‘dumbs it down’. However, if the use of scientific terminology will only cause the audience to misunderstand — or, worse, completely misinterpret what is being said — then it makes no sense to use it, as the result will only be confusion. Scientists should never expect people outside their discipline to understand the exact meaning they ascribe to a specialised term — even an apparently simple one like ‘model’. Every effort should be made to re-phrase the language so that it has meaning to the audience. This sometimes takes more time and effort than some researchers can spare, and is the reason for the growing value of the skilled communicator as a messenger and interpreter between science and society.

\* jargon: (특정 집단 내의) 전문어 \*\* dumb ~ down: ~을 지나치게 단순화하다 \*\*\* terminology: 용어

- ① 과학자는 자신의 연구에서 각 개념을 정확하게 정의해야 한다.
- ② 새로운 과학 이론을 제시할 때는 충분한 근거를 제시해야 한다.
- ③ 어려운 과학 용어를 알기 쉽게 정비한 용어집을 만들어야 한다.
- ④ 과학은 일반 독자들이 이해할 수 있도록 쉬운 언어로 설명되어야 한다.
- ⑤ 논문은 각 전공 분야별로 정해진 엄격한 형식에 따라 작성되어야 한다.

04

밑줄 친 failing to dip into the thought processes that go through the black boxes가 다음 글에서 의미하는 바로 가장 적절한 것은?

25007-0176

Creativity is significantly different from pursuit of excellence. When limits to excellence begin to operate, only creativity and innovation can take companies to different trajectories. In a competitive and uncertain world, companies that are creative would most certainly have advantage over companies that are not. Nevertheless, creativity figures low in corporate agenda as a work or organizational ethic that needs to be institutionalized. For most organizations, only the visible working of an employee mind to follow the prescribed practices is relevant. The employee mind is considered similar to a black box (“one can never fathom what happens inside a human brain, nor is it necessary”)! For most organizations, their environmental view rarely goes beyond an explored business canvas into unexplored white spaces (“one has to have deep pockets to lose money on white spaces”)! By failing to dip into the thought processes that go through the black boxes, companies miss out on the opportunities of white-space growth that lies ahead of them.

\* trajectory: 궤도 \*\* agenda: 의제 \*\*\* fathom: 헤아리다

- ① carelessly overlooking the prescribed practices of workplace safety
- ② consistently not hiring employees who meet the essential qualifications
- ③ discouraging the organizational environment of openness and transparency
- ④ not properly equipping systems to effectively evaluate employees' creativity
- ⑤ not adequately exploring creative thinking processes within employees' minds

## 05 다음 글의 요지로 가장 적절한 것은?

25007-0177

Life is perhaps 5% (or less) what happens to us and 95% (or more) how we interpret and respond to what is happening. It is our interpretation of external events that gives them meaning. Situations and circumstances are neutral until we decide what they mean whether positive, negative, or insignificant. Individuals in the excellence category refuse to accept the limiting biases and judgments of others. They make their own interpretations, and decide accordingly. There is an often-noted parable about a shoe factory that sends two marketing scouts to a distant country to study the possibilities of expanding the shoe business. The first scout sends back a message that the situation is hopeless, no one wears shoes, and there is no market. The other scout responds enthusiastically that this is an outstanding business opportunity since no one has shoes. In any situation, the meaning we give to circumstances determines what we see and how we think and act.

\* parable: 비유

- ① 과거 경험은 상황에 대한 해석 방식에 큰 영향을 준다.
- ② 상황에 대한 해석이 개인의 생각과 결정에 영향을 미친다.
- ③ 문제를 정확히 인식하는 것이 문제 해결 과정의 첫 단계이다.
- ④ 부정적 상황을 긍정적으로 바꾸는 경험을 통해 개인은 발전한다.
- ⑤ 문화에 대한 편견은 사업상 중요한 결정에 부정적인 영향을 준다.

## 06 다음 글의 주제로 가장 적절한 것은?

25007-0178

One area of research that's become increasingly popular among food scientists is the arena of phantom aromas. Once in a while you might imagine a smell that isn't actually around you. Aroma is the sense that is most strongly associated with memory, and this relationship can be manipulated during cooking to trick our brain to reconstruct what it perceives the food should taste like. Ham is a salt-cured meat, and we've learned to associate the aroma of ham with saltiness. In a taste experiment, the presence of "ham aroma" in food samples convinced a group of people that their food tasted saltier. You can play with this yourself. If you repeatedly use aromatic spices such as cinnamon, rosewater, and vanilla in desserts, you start to associate those aromas with sweetness. The next time you make a dessert such as Polenta Kheer, cut back on the amount of added sweetener and add a bit more of the "sweeter" aromatic spice. Your dinner companions will probably find that the dessert tastes very sweet.

\* phantom: 착각에 의한, 환상의 \*\* salt-cured: 소금 절임 된 \*\*\* Polenta Kheer: 옥수수 키르(인도 지역의 디저트)

- ① the use of popular tastes and aromas in the field of marketing
- ② the cause of the sensitivity of some individuals to specific flavors
- ③ the manipulation of aroma-memory associations in food perception
- ④ the scientific methods applied to boost the nutritional value in daily food
- ⑤ the technique used to create more flavorful desserts with artificial flavorings

## 07 다음 글의 제목으로 가장 적절한 것은?

25007-0179

Overoptimism may be partially explained by “representativeness bias.” Representativeness bias is the result of a heuristic whereby individuals generalize from particular “representative” cases, even when better general statistical information exists. It is easy to see why the representativeness heuristic might be useful in everyday reasoning — specific information is often more accurate or more useful than general information, and favoring it may represent a useful cognitive shortcut when assessing probabilities. However, when this assumption fails, the representativeness heuristic can lead to bizarre and erroneous judgments. Overoptimism may result from representativeness when, for example, individuals infer from knowledge about a specific car accident involving a bad driver that bad driving correlates with accidents more highly than it does in fact. In this case, even if they believe they are average drivers, they will systematically underestimate the probability that they will be involved in an accident, because the representativeness heuristic will have generated an underestimation of the probability that average drivers are involved in accidents.

\* representativeness: 대표성 \*\* heuristic: 경험칙, 어림짐작 \*\*\* bizarre: 기이한

- ① How Mental Shortcuts Help Us Make Quick Decisions
- ② The Power of a Positive Attitude to Drive Forward Progress
- ③ Obstacles as Stepping Stones: Turning Challenges into Victories
- ④ Thinking Mistakes: How Mental Shortcuts Cause Overoptimism
- ⑤ Wearing Many Hats: How Managing Multiple Tasks Can Boost Productivity

## 08 다음 도표의 내용과 일치하지 않는 것은?

25007-0180

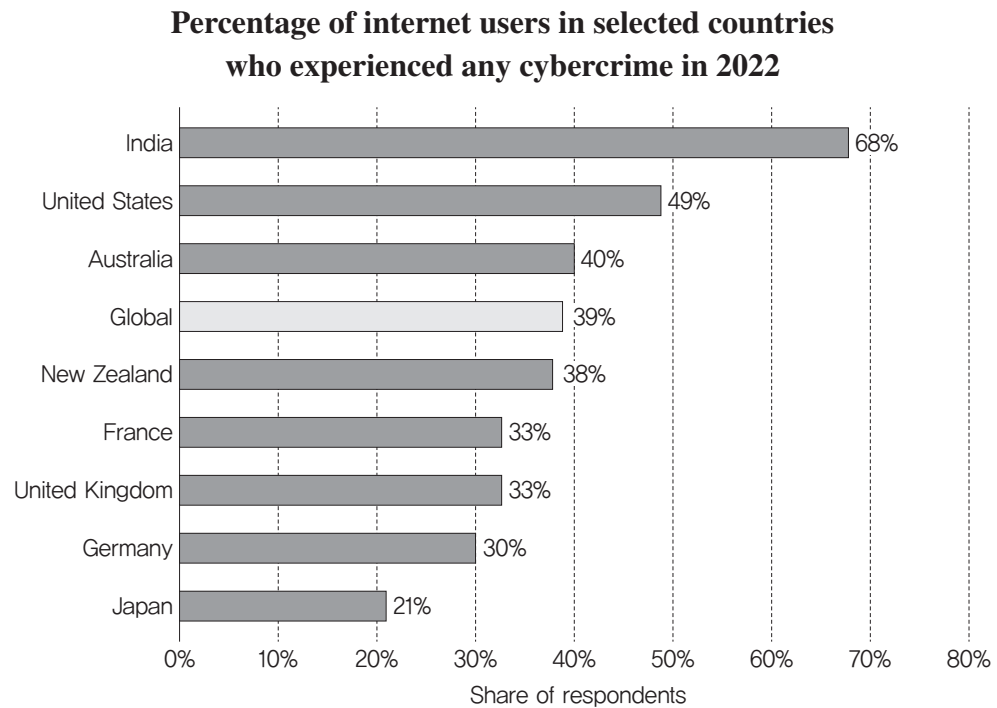

The graph above shows the percentage of internet users who experienced any cybercrime in a selection of countries in 2022, including a reference to the global average. ① Among the surveyed countries, India reported the highest percentage of internet users experiencing cybercrime, followed by the United States, where nearly half of the internet users encountered such incidents. ② Conversely, Japan reported the lowest rate of cybercrime encounters among its internet users, and Germany had the second lowest rate, with more than a quarter of respondents acknowledging experiencing cybercriminal activities. ③ Australia recorded the third highest percentage of internet users among the selected countries, who experienced any cybercrime, at 1 percentage point above the global average. ④ In the three countries above the global average, at least four out of ten respondents said that they experienced any cybercrime. ⑤ In all of the countries where the proportion of respondents reporting cybercrime was below the global average, at least more than one-third of their internet users still experienced some form of cybercrime.

09

Francis William Aston에 관한 다음 글의 내용과 일치하지 않는 것은?

25007-0181

Francis William Aston, a British chemist and physicist, was born in Harborne, England, the son of a metal merchant. He was educated at Mason College, the forerunner of Birmingham University, where he studied chemistry. From 1898 until 1900, he did research under P. F. Frankland on optical rotation. He left Birmingham in 1900 to work in a Wolverhampton brewery for three years. During this time he continued with scientific research in a home laboratory, where he worked on the production of vacua for x-ray discharge tubes. This work came to the notice of J. H. Poynting of the University of Birmingham, who invited Aston to work with him. He remained at Birmingham until 1910, when he moved to Cambridge as research assistant to J. J. Thomson. He became a research fellow at Cambridge in 1920 and stayed there for the rest of his life, apart from the war years spent at the Royal Aircraft Establishment, Farnborough. Aston's main work, for which he received the Nobel Prize for chemistry in 1922, was on the design and use of the mass spectrograph, which was used to clear up several outstanding problems and became one of the basic tools of the new atomic physics.

\* forerunner: 전신(前身) \*\* brewery: 맥주 공장 \*\*\* mass spectrograph: 질량 분석기

- ① Mason College에서 화학을 공부했다.
- ② J. H. Poynting으로부터 함께 연구하자는 요청을 받았다.
- ③ 1910년에 Cambridge로 가서 J. J. Thomson의 연구 조수로 일했다.
- ④ 전쟁 기간 내내 Cambridge를 떠나지 않았다.
- ⑤ 1922년 노벨 화학상을 수상했다.

## 10 Caremaxy Shoe Dryer에 관한 다음 안내문의 내용과 일치하지 않는 것은?

25007-0182

### Caremaxy Shoe Dryer

This device removes moisture by drying your shoes and eliminates bacteria using Active Oxygen (Ozone) technology.

#### Operation:

1. Place your shoes over the holders.
2. Press the power button to start. If necessary, you can adjust the timer, which is initially set to 120 minutes.
3. Press the Dry button. The drying light will come on, starting the drying process.  
When the process has finished, the dryer will stop automatically.

#### Using the Ozone Function:

- Press the Ozone button to switch it on. It automatically turns off after 15 minutes.
- Press the Ozone button again to restart the ozone function if necessary.
- Note that when the ozone function is on, the unit will not generate heat. Heat is only produced after the ozone function is turned off.

#### Safety Instructions:

- Excessive ozone can lead to poor air quality, causing headaches.
- Keep the dryer away from water to prevent damage.

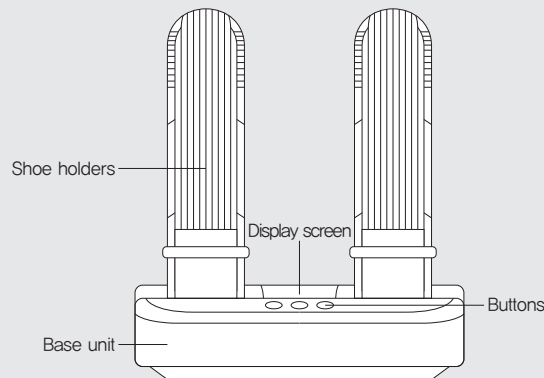

- ① 타이머를 조정할 수 있으며 최초 120분으로 설정되어 있다.
- ② 건조 과정이 끝나면 건조기가 자동으로 정지된다.
- ③ 오존 기능은 15분 후 자동으로 꺼진다.
- ④ 오존 기능이 작동 중일 때 기기에서 열이 발생한다.
- ⑤ 과도한 오존은 공기질 저하로 이어져 두통을 유발할 수 있다.

11

Woodlaw School Book Fair에 관한 다음 안내문의 내용과 일치하는 것은?

25007-0183

### Woodlaw School Book Fair

The Woodlaw School Book Fair provides an opportunity for students of all ages to enrich their home libraries and cultivate a love for reading.

#### What to expect:

- The book fair will take place from March 10 to March 14 in the Woodlaw library.
- Students will have the chance to explore and purchase books during designated class times.
- Additionally, there will be a Family Night on Wednesday, March 12, from 4:45 pm to 7:30 pm.

#### How to pay:

- The book fair offers eWallet, a secure alternative to cash.
- Simply create a free account to add funds and invite family and friends to contribute.
- All sales amounts and any unused funds will be donated to the local community center's children's library building fund.

For more information, email us at [bookfair@woodlawschool.ac.us](mailto:bookfair@woodlawschool.ac.us).

- ① 참가 대상 학생에 대한 연령 제한이 있다.
- ② 3월 10일부터 일주일간 진행된다.
- ③ 3월 12일 수요일 오후 가족의 밤이 예정되어 있다.
- ④ 올해 행사에서는 eWallet이 제공되지 않는다.
- ⑤ 책 판매 금액을 제외한 미사용 기금은 전액 기부된다.

## 12 다음 글의 밑줄 친 부분 중, 어법상 틀린 것은?

25007-0184

Requests to take part politically arise from a variety of sources: through social media, or in a sermon at church, or from the newsletter of an organization ① of which one is a member, or directly from a friend, neighbor, or co-worker. Because those who attempt to get others ② involved in politics act as “rational prospectors,” the ordinary processes through which people are asked to take part do not ameliorate the class bias in individual political voice. Seeking to get results as efficiently as possible, rational prospectors aim their requests at those who are likely not only to say yes but also, on assenting, ③ to participate effectively. Often they target people who have been active in the past. The result is that participation undertaken in response to requests from others ④ bring in a disproportionate share of previous activists, which in turn exaggerates the socioeconomic status bias of political participation. In this way, ordinary processes of recruitment to political involvement do not simply replicate the socioeconomic structuring of political participation: they actually amplify ⑤ it.

\* ameliorate: 개선하다   \*\* assent: 동의하다   \*\*\* replicate: 복제하다

### 13 다음 글의 밑줄 친 부분 중, 문맥상 낱말의 쓰임이 적절하지 않은 것은?

25007-0185

Storing too many memories could slow down the process of retrieval, so memories that are deemed ① irrelevant are quietly erased. This is why you probably cannot remember what you had for breakfast two Fridays ago as such information is unlikely to be useful. This of course raises the question as to how we can determine in advance whether or not a memory is likely to be useful in the future. One factor is ② emotion. In times of great stress, people will often have very detailed memories of the event; in extreme cases this can manifest itself as post-traumatic stress disorder (PTSD). Sufferers of PTSD can be overwhelmed by memories of traumatic events and can show hypervigilance in ③ threatening situations. Although PTSD is clearly maladaptive, it may be an extreme form of a process that is evolutionarily ④ useful. It would surely be good design to ensure that an animal that has had, for example, a near-death experience would learn from that experience and ⑤ suppress vigilance in similar situations.

\* retrieval: (기억) 인출 \*\* deem: (~이라고) 여기다 \*\*\* hypervigilance: 과도한 경계

## 14 다음 빈칸에 들어갈 말로 가장 적절한 것은?

25007-0186

One example of information that has greatest value when it is in the \_\_\_\_\_ of a human operator can be found in the context of driving. Vehicles today are designed with increasingly sophisticated sensor packages aimed at detecting a variety of aspects of the driving environment. For example, forward-looking cameras and forward-looking radar systems can judge the distance to vehicles in front of a driver. Computations that measure this information over time reveal changes in distance. This information can be used to alert a driver when the change in distance for a given vehicle speed is rapid enough to suggest a collision might take place. That information is important, but it is only valuable if the driver acts on it. (Unless, of course, the vehicle itself acts on it without driver intervention.) The key here is that the driver must have the ability to pay attention to the information for the information to have value to the driver. If the driver is distracted by a phone, for example, they might fail to process the important information the vehicle is presenting.

\* collision: 충돌

- ① criticism
- ② imagination
- ③ conscience
- ④ awareness
- ⑤ patience

## 15 다음 빈칸에 들어갈 말로 가장 적절한 것은?

25007-0187

A biologist, Tyler Volk, points out that cells are self-generated dynamic entities that at any given moment are always on the cusp between persisting and dying. They manage to survive by using their metabolism to stay ahead in this game. When metabolic wastes are expelled, the result is a loss of molecules. To compensate, cells also use metabolism to grow new molecules. If the exchange is at least equal, the cell can persist in its present form. If more molecules are generated than are lost, which adds protection against dying, net growth results, and the cell gets bigger. But a cell can only grow so much, as larger cells require more nutrients, and the cell runs up against a basic principle of physics — as a sphere gets bigger, its interior increases to a greater degree than its surface area. For a cell, this makes it harder for the surface to keep the flow of nutrients high enough to sustain the ever-larger interior. So what's a cell to do? It divides in half and starts the process all over as it approaches its useful size limit. This \_\_\_\_\_.

\* entity: 독립체 \*\* on the cusp: ~의 경계에 있는 \*\*\* metabolism: 신진대사

- ① achieves a balance between growth and persistence
- ② makes it difficult for a new cell to regrow its damaged parts
- ③ causes a cell to find a different source of nutrients to rely on
- ④ boosts the energy intake for cells to become indefinitely bigger
- ⑤ creates a channel for cells to exchange molecules between each other

## 16 다음 빈칸에 들어갈 말로 가장 적절한 것은?

25007-0188

In a study, Iowa State University researchers read people lists of words, and then asked for each list to be recited back either right away, after fifteen seconds of rehearsal, or after fifteen seconds of doing very simple math problems that prevented rehearsal. The subjects who were allowed to reproduce the lists right after hearing them did the best. Those who had fifteen seconds to rehearse before reciting came in second. The group distracted with math problems finished last. Later, when everyone thought they were finished, they were all surprised with a pop quiz: write down every word you can recall from the lists. Suddenly, the worst group became the best. Short-term rehearsal gave purely short-term benefits. Struggling to hold on to information and then recall it had helped the group distracted by math problems transfer the information from short-term to long-term memory. The group with more and immediate rehearsal opportunity recalled nearly nothing on the pop quiz. Repetition, it turned out, was \_\_\_\_\_.

- ① essential for memorization
- ② less important than struggle
- ③ required before intensive practice
- ④ helpful in early language development
- ⑤ ineffective for understanding complex ideas

## 17 다음 빈칸에 들어갈 말로 가장 적절한 것은?

25007-0189

Psychological safety plays a powerful role in the science of failing well. It allows people to ask for help when they're in over their heads, which helps eliminate preventable failures. It helps them report — and hence catch and correct — errors to avoid worse outcomes, and it makes it possible to experiment in thoughtful ways to generate new discoveries. Think about the teams that you've been a part of at work or at school. These groups probably varied in psychological safety. Maybe in some you felt completely comfortable speaking up with a new idea, or disagreeing with a team leader. In other teams you might have felt it was better to hold back — to wait and see what happened or what other people did and said before sticking your neck out. That difference is now called psychological safety — and I have found in my research that it's an emergent property of a group, not a personality difference. This means your perception of whether it's safe to speak up at work is unrelated to whether you're an extrovert or an introvert. Instead, it's shaped by \_\_\_\_\_.

\* emergent property: 창발성(구성 요소에는 없으나 상위 구조에서 출현하는 특성)

- ① whether you have been in a similar situation before
- ② how much interest you have in the issue being discussed
- ③ how much more you know than others about the matter at hand
- ④ whether your thoughts are valued by your family members or not
- ⑤ how people around you react to things that you and others say and do

## 18 다음 글에서 전체 흐름과 관계 없는 문장은?

25007-0190

We live in a highly mobile world, where people are regularly uprooted from their home locales. Some do so by choice, but for others political or economic conditions force them to relocate to vastly different physical and cultural places. ① In these circumstances, aside from their private realms, public space plays a role in creating a sense of belonging to a new place. ② The sensory qualities of public space — the smell of the sea, a familiar tree, the design of a fence, the quality of light, a soccer field — have an utmost capacity to create a connection to “home” for the new arrivals. ③ These seemingly ephemeral qualities of public space can bring deep psychological comfort by triggering a familiar memory, creating an interconnectedness, or forming a continuum between the past and the present. ④ In a way, cities are massive public spaces divided into private spaces, whereas the suburbs are a bunch of private territories that make up mostly residential areas. ⑤ These experiences in and of public space can also establish a common or shared experience between the locals and the newcomers.

\* ephemeral: 일시적인

# 19 주어진 글 다음에 이어질 글의 순서로 가장 적절한 것은?

25007-0191

The brain does not try to use all of its billions of neurons to represent everything; different brain regions represent different kinds of sensory stimuli.

- (A) Thus, different parts of the brain have groups of neurons that fire when different kinds of visual, olfactory (smell), taste, auditory, and touch stimuli are presented. The human brain can do a lot more than just represent stimuli presented to it, because a group of neurons can respond to inputs from many groups of neurons.
- (B) This can produce a combined representation of what the input neurons represent. For example, there are regions in the frontal cortex of monkeys where the sensory modalities of taste, vision, and smell come together, enabling the representation of fruits and their key properties. It is clear, therefore, that the brain is a superb representational device.
- (C) For example, the visual cortex at the back of the brain has neurons that respond to different visual inputs. There are neuronal groups whose firing patterns correspond spatially to the structure of the input — for example, when a column of neurons fires together to represent the fact that a line is part of the visual stimulus.

\* frontal cortex: 전두엽 피질 \*\* sensory modality: 감각 양상

① (A) - (C) - (B)

② (B) - (A) - (C)

③ (B) - (C) - (A)

④ (C) - (A) - (B)

⑤ (C) - (B) - (A)

## 20 주어진 글 다음에 이어질 글의 순서로 가장 적절한 것은?

25007-0192

For the last few centuries, experts have worried ceaselessly that we aren't exercising enough.

- (A) An especially influential proponent of this movement was Friedrich Jahn, the "Father of Gymnastics." Following Napoleon's humiliating string of victories over German armies in the early nineteenth century, Jahn argued that educators had a responsibility to restore the physical and moral strength of his nation's youth with gymnastics, hiking, running, and more.
- (B) Nationalism is one major source of this anxiety. Just as ancient Spartans were required and Romans were urged to be fit enough to fight as soldiers, flag-waving leaders and educators increasingly encouraged ordinary citizens to participate in sports and other forms of exercise as preparation for military service.
- (C) Later, similar worries in America were spurred by the embarrassing lack of fitness among many men who enlisted or were drafted for World Wars I and II and by the poor state of fitness among schoolchildren at the start of the Cold War. National movements to drum up fitness for the sake of the state still occur in China and elsewhere.

\* proponent: 지지자 \*\* spur: 불러일으키다 \*\*\* enlist: 입대하다

- ① (A) - (C) - (B)                      ② (B) - (A) - (C)                      ③ (B) - (C) - (A)  
 ④ (C) - (A) - (B)                      ⑤ (C) - (B) - (A)

## 21 글의 흐름으로 보아, 주어진 문장이 들어가기에 가장 적절한 곳은?

25007-0193

It may be, however, that warming will be experienced as a reduction in the fall of temperature at night, due to increased cloudiness, with little or no change in daytime temperatures.

Many climatologists accept there is a real possibility of global climatic warming due to an enhanced greenhouse effect. As with many large-scale changes, there would be winners and losers. ( ① ) Were climate belts to shift toward higher latitudes, which seems the most likely overall result, parts of the Sahara and southern Russia would receive increased rainfall. ( ② ) They would benefit and their agricultural output would increase. ( ③ ) On the other hand, southern Europe and the United States cereal belt might become drier. ( ④ ) If warming produced a rate of evaporation that exceeded the increase in the rate of precipitation, soils would become more arid. ( ⑤ ) In that event, nighttime frosts would become less frequent, soils would become somewhat moister, and agriculture would benefit.

\* latitudes: 위도 지역 \*\* precipitation: 강수량 \*\*\* arid: 메마른

## 22

글의 흐름으로 보아, 주어진 문장이 들어가기에 가장 적절한 곳은?

25007-0194

For example, many social media platforms do not fit well with skills such as writing essays and giving formal presentations.

Social media platforms enhance learning experiences, increase student interaction, and foster engagement. However, just like with other pedagogical activities, understand the why behind what you do with social media. ( ① ) Knowing this reason will guide you with choosing the most effective digital tool for reaching your instructional goals. ( ② ) Be sure to match your instructional goals with digital tools that are accessible on websites and apps. ( ③ ) When selecting digital tools, refrain from being attracted to apps with fireworks and flying colors because such highly attractive apps may not necessarily serve your academic purposes nor your students' learning needs. ( ④ ) Selecting a social media platform is a practical decision based on making a good fit with a targeted skill. ( ⑤ ) Yet, these platforms can enhance other pedagogical activities such as classroom assessment techniques by allowing students to provide virtual input about a topic through social interaction.

\* pedagogical: 교육적인

23

다음 글의 내용을 한 문장으로 요약하고자 한다. 빈칸 (A), (B)에 들어갈 말로 가장 적절한 것은?

25007-0195

The only way to produce crystal-clear writing is to know how a reader will respond to the choices you make in composing text and graphics. You need to know which sentence structures are most easily understood, which organization of material into sections is most easily followed, and so on. It's certainly possible to offer some general rules along these lines: for example, "use the active voice," "divide the paper into Introduction, Methods, Results, and Discussion sections," and "use a figure instead of a table when quantities are to be compared." In principle, you could tape a long list of such rules above your computer and treat it as the voice of authority on how to reach readers. But long lists of rules are boring. Besides, using them makes writing mechanical, and good writing sometimes entails knowing when to bend the rules instead of following them. Furthermore, using a list of rules is oddly indirect: instead of relying on rules you've been told will produce clear text, surely it would be more effective to understand how readers think, and write to that understanding.



In order to produce clear writing, you need to grasp the viewpoint of your \_\_\_\_\_ (A) and apply general writing rules \_\_\_\_\_ (B).

- | (A)        | (B)            |
|------------|----------------|
| ① audience | flexibly       |
| ② audience | consistently   |
| ③ editor   | systematically |
| ④ editor   | consistently   |
| ⑤ peers    | flexibly       |

[24~25] 다음 글을 읽고, 물음에 답하시오.

In the early 1970s, the Peace Corps office in Botswana was concerned by the number of volunteers who seemed to be “burned out,” failing in their assignments, leaving the assigned villages, and increasingly hostile to their Tswana hosts. The Peace Corps asked American anthropologist Hoyt Alverson, who was (a) familiar with Tswana culture and society, for advice. Alverson discovered that one major problem the Peace Corps volunteers were having involved exactly the issue of (b) similar actions having very different meanings. The volunteers complained that the Tswana would never leave them alone. Whenever they tried to get away and sit by themselves for a few minutes to have some private time, one or more Tswana would quickly join them. This made the Americans (c) angry. From their perspective, everyone is entitled to a certain amount of privacy and time alone. To the Tswana, however, human life is (d) social life; the only people who want to be alone are witches and the insane. Because these young Americans did not seem to be either, the Tswana who saw them sitting alone naturally assumed that there had been a breakdown in hospitality and that the volunteers would (e) reject some company. Here, one behavior — a person walking out into a field and sitting by himself or herself — had two very different meanings.

\* the Peace Corps: (미국의) 평화 봉사단

**24** 윗글의 제목으로 가장 적절한 것은?

25007-0196

- ① Social Evolution: Adapting to Change in a Connected World
- ② Creative Solutions for Coping with and Managing Challenges
- ③ The Heart of Volunteering: Making a Difference Where It Counts
- ④ Uncovering Cross-cultural Misunderstandings: Action vs. Meaning
- ⑤ Universal Values and Diverse Expressions of Hospitality Across Cultures

**25** 밑줄 친 (a)~(e) 중에서 문맥상 낱말의 쓰임이 적절하지 않은 것은?

25007-0197

- ① (a)                      ② (b)                      ③ (c)                      ④ (d)                      ⑤ (e)

[26~28] 다음 글을 읽고, 물음에 답하십시오.

(A)

In the heart of the forest, there lived a young eagle named Edge and his twin brother, Jo. Jo could soar high in the sky and experience the freedom of flight, while Edge was born with a damaged wing and was unable to fly. Although this could have discouraged (a) him greatly, he never lost hope and always believed that he would one day achieve his dream of flying alongside Jo.

\* soar: 날아오르다

(B)

Finding the mystical herb would be difficult and dangerous, so Jo tried to persuade him not to go. However, Edge was determined to find the herb. In the end, Jo understood and wished him a safe and successful journey. Edge set off on his journey, which was especially challenging because of his damaged wing, forcing (b) him to climb the mountain on foot. At one point, a sudden landslide wiped out the path he had been following, making him start the climb all over again. He encountered many other obstacles along the way, but he never gave up. Finally, after several days of climbing, he reached the top of the mountain and found the mystical herb.

\* mystical: 신비로운 \*\* landslide: 산사태

(C)

When Edge returned to the sage, the sage used the mystical herb to fix Edge's wing. With Jo cheering him on, Edge spread his wings and took off into the sky for the first time. He felt the wind rushing past (c) him and the sun shining on his feathers. From that day forward, the two brothers often flew together and explored the vast skies. Edge became a symbol of hope and determination. And even though he never forgot the sage who had helped him achieve his dream, Edge also knew that his true spirit came from within, which gave (d) him the strength to overcome any obstacle.

\* sage: 현자

(D)

One day, Jo and Edge met an old sage while they were looking for food. Known for his wisdom, the sage lived alone in a small hut hidden among the trees. Wanting his twin brother to achieve his dream, Jo eagerly asked if the sage could help Edge fly. The sage took pity on the young eagle and told Edge about a mystical herb. The herb grew on the top of the tallest mountain in the forest and glowed blue. He said that if Edge was able to find the mystical herb and bring it back to (e) him, he would be able to fix his wing so he could fly.

**26** 주어진 글 (A)에 이어질 내용을 순서에 맞게 배열한 것으로 가장 적절한 것은?

25007-0198

- ① (B) - (D) - (C)                      ② (C) - (B) - (D)                      ③ (C) - (D) - (B)  
 ④ (D) - (B) - (C)                      ⑤ (D) - (C) - (B)

**27** 밑줄 친 (a)~(e) 중에서 가리키는 대상이 나머지 넷과 다른 것은?

25007-0199

- ① (a)                      ② (b)                      ③ (c)                      ④ (d)                      ⑤ (e)

**28** 밑글에 관한 내용으로 적절하지 않은 것은?

25007-0200

- ① Edge는 손상된 날개를 가지고 태어났다.  
 ② 갑작스러운 산사태는 Edge가 따라가던 길을 쓸어 버렸다.  
 ③ Edge는 희망과 결단력의 상징이 되었다.  
 ④ 현자는 나무들 사이에 숨겨진 작은 오두막에서 혼자 살았다.  
 ⑤ 약초는 산의 가장 깊숙한 곳에서 자라며 푸른 빛을 발했다.

## 01 다음 글의 목적으로 가장 적절한 것은?

25007-0201

[Monday, January 20, 2025]

Dear Parents/Guardians and Students of TBS High School,

Thank you for your patience during the heavy snowstorm that dropped more than 40 cm of snow in Calbary. This evening, the City of Calbary has issued a snowstorm alert and is encouraging residents to stay home. At TBS High School, we are also facing several concerns: students may not be able to walk to school safely, and many school buses will likely be delayed or, in some cases, canceled. With all of this in mind, we have made the decision to close our school on Tuesday, January 21. Students may either work on previously assigned tasks or spend time reviewing material previously covered at home. Thank you for your patience and understanding.

Sincerely,  
Caroline R. Robbins  
TBS High School Principal

- ① 과제 평가 결과를 통지하려고
- ② 폭설로 인한 휴교를 공지하려고
- ③ 폭설 시 대피 요령을 안내하려고
- ④ 눈 치우기 운동 참여를 요청하려고
- ⑤ 학교 축제 일정 변경 이유를 설명하려고

## 02 다음 글에 드러난 'I'의 심경 변화로 가장 적절한 것은?

25007-0202

By the time our family arrived at the Church of Santa Teresa, I tried to soak up the chapel's beauty in silence. However, I found a group of people singing loudly in the corner of the chapel. *Why are these people ruining my trip? Do they even know what this place is?* To make matters worse, they started dancing, too! My moment with the chapel was completely ruined by their inconsiderate behavior. Suddenly, some women in the group began motioning for me to join in. I attempted to decline by taking backward steps. Still, they just kept stretching their hands toward me. I looked down at my daughter, who looked back at me with curiosity. I shrugged and smiled. The next thing I knew, we were dancing together with huge smiles on our faces. As I squeezed my daughter's hand and did my best to keep time with the lively beat, my heart was filled with joy. I knew that this would be my favorite memory of the trip.

- ① hopeful → stressed
- ② ashamed → relaxed
- ③ bored → frightened
- ④ annoyed → delighted
- ⑤ excited → disappointed

## 03 다음 글에서 필자가 주장하는 바로 가장 적절한 것은?

25007-0203

For better or worse, we see the world through a singular lens that often causes us to fall victim to certain biases. I've seen a number of entrepreneurs who built successful businesses and attributed all of their achievements to their own ingenuity. These people tend to lack the self-reflection and objectivity to see that their accomplishments likely would not have been possible without the assistance of various people and institutions external to themselves. It's all too easy to see failures in our lives as purely or predominantly due to outside (external) forces, and successes in our lives as purely or predominantly due to inside (internal) forces. Therefore, we must know that credit must be given and shared. Apple's success wasn't exclusively Steve Jobs's, nor was Microsoft's success exclusively Bill Gates's. Santa has thousands of little helpers who allow him to achieve the impossible. It takes a team of people (or elves) and a huge network for us to accomplish anything.

\* entrepreneur: 사업가 \*\* ingenuity: 재간

- ① 목표 설정 시 조직의 취약점을 분석하는 것이 우선되어야 한다.
- ② 자신의 성취 뒤에는 다른 사람들의 도움이 있음을 인정해야 한다.
- ③ 리더는 직원들과의 소통을 통해 끊임없이 상황을 개선해야 한다.
- ④ 조직의 발전을 위해서는 자신의 이익과 타인의 이익을 조율해야 한다.
- ⑤ 자신의 분야에서 성공하기 위해서는 그 분야에 대한 열정을 가져야 한다.

## 04 밑줄 친 Everyone loves a good story.가 다음 글에서 의미하는 바로 가장 적절한 것은?

25007-0204

We tend to believe people who share our beliefs without taking the time to fact-check all the information. With the emergence of ‘identity politics’, this has given rise to the recent phenomenon of fake news. Anything that doesn’t conform to your tribe’s views is rejected and labelled as fake news. It is not always falsified information, but it is often opinions that differ hugely from our own that are labelled fake news by politicians and the media alike. Jonathan Freedland in the *Guardian* terms it a new kind of cognitive bias called Tribal Epistemology, which is when the truth no longer corresponds to facts or evidence but rather when a specific assertion agrees with the viewpoint of the tribe or social group one belongs to. The boundaries between ‘works for us’ or ‘good for us’ and ‘true’ have blurred. Of course, this isn’t a new phenomenon; we have been sorting ourselves into tribes since the beginning of human evolution. It has just been ignited by the recent political climate, media and technology, and by our tendency to believe in stories and narratives rather than facts. Everyone loves a good story.

\* epistemology: 인식론 \*\* blur: 흐릿해지다 \*\*\* ignite: 불을 붙이다

- ① A good story is the only way to unite everyone in a society.
- ② We live in a world of fake news because of information overload.
- ③ We blindly follow the story that fits our social group’s viewpoints.
- ④ The art of storytelling involves finding ways to connect with others.
- ⑤ Combining old and new experiences helps us create an appealing story.

## 05 다음 글의 요지로 가장 적절한 것은?

25007-0205

Ambiguity is an uncomfortable feeling for most people. As such, it's one that we tend to quickly misattribute, concluding that something must be wrong. But in fact, ambiguity can be a productive, even positive state. When we conduct research, we try to encourage ourselves, our students, and our colleagues to enjoy a state of ambiguity. The logic is that when we don't know the answer, real knowledge can arise, so it is best to go slowly, think carefully, and enjoy the process of trying to find out what is going on. Sadly, this love of ambiguity is an uncommon mindset. Usually we want quick and clear answers, especially when we are stressed. For some people, this antipathy to ambiguity contributes to their descent into misbelief. The ability not to rush to conclusions, to keep multiple hypotheses in mind, and to remain open to new information and possibilities is key to not getting sucked into misbelief. We tend to admire and seek out conviction and confidence. But we would be better served if we learned to admire and enjoy a state of ambiguity.

\* antipathy: 반감, 혐오 \*\* descent: 전락, 하락

- ① 사건 간 인과 관계를 명확하게 파악하는 것이 문제 해결의 출발점이다.
- ② 나와 생각이 다른 사람과 꾸준히 교류해야 진정한 지식에 도달할 수 있다.
- ③ 명확한 정보가 부족한 상황에서는 다양한 시나리오를 만들어 대비해야 한다.
- ④ 연구 결과를 보고할 때 모호한 표현을 사용하면 연구의 신뢰성을 떨어뜨릴 수 있다.
- ⑤ 모호함의 상태를 기꺼이 받아들이는 사고방식을 가져야 잘못된 믿음에 빠지지 않는다.

## 06 다음 글의 주제로 가장 적절한 것은?

25007-0206

When leaders in companies, nonprofits, or governments invest in artificial intelligence, much of their attention goes to hiring machine learning experts or paying for tools. But this misses a critical opportunity. For organizations to get the most that they can from AI, they should also be investing in helping all of their team members to understand the technology better. Understanding machine learning can make an employee more likely to spot potential applications in their own work. Many of the most promising uses for machine learning will be humdrum, and this is where technology can be at its most useful: saving people time, so that they can concentrate on the many tasks at which they outperform machines. An executive assistant who has a better understanding of machine learning might suggest that calendar software learn more explicitly from patterns that develop over time, reminding them when their boss has not met with a team member for an unusually long time. A calendar that learns patterns could give an executive assistant more time for the human specialties of the job, such as helping their boss to manage a team.

\* humdrum: 단조로운, 평범한

- ① benefits of introducing AI-based management tools
- ② difficulty of hiring competent machine learning experts
- ③ reasons for retaining human employees in the age of AI
- ④ ways of overcoming management reluctance to embrace AI
- ⑤ necessity of investing in enhancing AI literacy for all employees

## 07 다음 글의 제목으로 가장 적절한 것은?

25007-0207

It's a useful cliché, repeated by practitioners and radio educators alike, that radio is 'theatre of the mind'. By telling stories using words, music and sound effects, radio can engage the imagination to communicate ideas and images that create a kind of narrative uniquely experienced by each individual listener. Through the omission of visual cues and by embracing the openness of the work, radio storytelling has the capacity to make personal connections, paint pictures with sound, and indeed create scenes that would be impossible in another context. The capacity of audio as a medium for imaginative and compelling storytelling is undiminished in the digital age, although the production, distribution and consumption cultures and technologies through which those stories are mediated have radically changed. In fact the possibilities for radiophonic narrative are in many ways expanded in the digital age, as research engineers, professionals and enthusiasts explore the parameters of new production processes, platforms and interactive opportunities, as well as opportunities for radio storytelling to be taken outside the realm of the radio professional.

\* cliché: 상투적인 표현 \*\* omission: 생략, 빠짐 \*\*\* radiophonic: 라디오의 소리 효과에 의한

- ① How Radio Storytelling Differs from Written Storytelling
- ② The Enduring Value of Radio Storytelling in the Digital Era
- ③ The Challenges Faced by Radio in a Changing Media Landscape
- ④ Beyond Entertainment: Radio's Lasting Impact on Shaping Culture
- ⑤ From Signals to Streaming: Exploring the Evolution of Radio Technology

## 08 다음 도표의 내용과 일치하지 않는 것은?

25007-0208

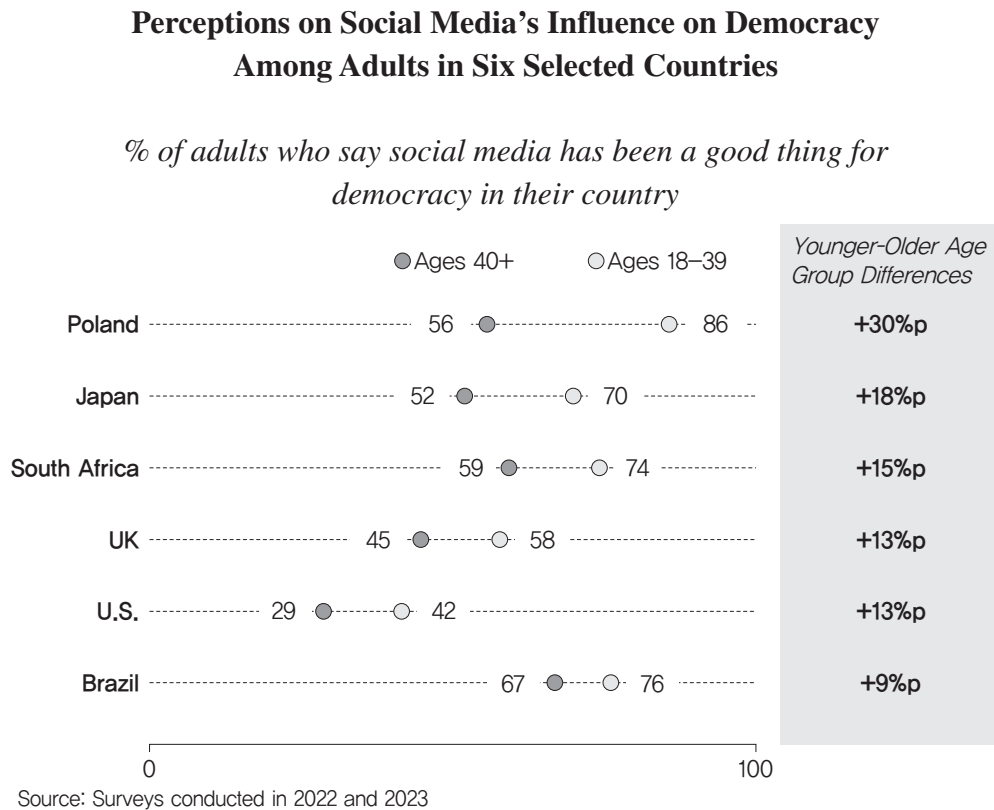

The graph above shows adults' views on social media's positive impact on democracy in six selected countries. ① For all the six countries in the graph, the percentages of younger adults (ages 18-39) saying social media has benefited democracy are higher than those of older adults (ages 40 and older). ② Among the six selected countries, the percentage point difference between the two age groups is the largest in Poland and the smallest in Brazil. ③ In both Japan and South Africa, over two-thirds of adults ages 18-39 say that social media has been beneficial for democracy. ④ In the UK, more than half of adults in the older age group say social media has benefited democracy in their country. ⑤ Among the six countries, the U.S. shows the lowest percentage of adults ages 40 and older who say social media has been positive for democracy in their country, at below 30 percent.

09

Barbara Hillary에 관한 다음 글의 내용과 일치하지 않는 것은?

25007-0209

Barbara Hillary was born in 1931 in New York City and raised in Harlem. Her family was poor, but she was encouraged to read. She majored in gerontology at the New School in New York City, and after graduating she became a nurse and worked for fifty-five years before retiring. At age 67, Hillary was diagnosed with lung cancer, which required surgery to remove. The surgery resulted in a 25 percent reduction in her breathing ability, but she would not let this stop her. She became interested in the North Pole after visiting Canada and taking pictures of polar bears. In the spring of 2007, at the age of 75, she became the oldest woman and the first African-American woman to ski to the North Pole. She reached the South Pole in 2011 at the age of 79, becoming the first African-American woman to reach both poles.

\* gerontology: 노인학

- ① New York City에서 태어나 Harlem에서 자랐다.
- ② 간호사가 되어 은퇴 전까지 55년간 일했다.
- ③ 67세에 폐암 진단을 받았다.
- ④ 캐나다를 방문해 북극곰의 사진을 찍은 후 북극에 대한 관심이 생겼다.
- ⑤ 2007년에 북극과 남극에 모두 도달한 최초의 아프리카계 미국인 여성이 되었다.

10

2025 Greenfields Horse Camp에 관한 다음 안내문의 내용과 일치하지 않는 것은?

25007-0210

### 2025 Greenfields Horse Camp

Join us for an unforgettable experience! This camp is for children aged 6–10, offering a safe and fun environment to make a life-long connection with horses.

#### Dates

- Session 1: July 7th – 11th
- Session 2: July 14th – 18th

#### Activities

During camp, participants will:

- learn how to ride in our indoor and outdoor facilities
- learn how to safely handle, feed, and take care of horses
- enjoy a variety of games and activities focused on learning about horses

#### Notes

- Camp runs from 9 a.m. to 2 p.m. Optional activities are available until 5 p.m. for an extra fee.
- Drinks are provided, but participants should bring a bag lunch.
- The fee for each session is \$250, with a separate \$50 sign-up fee.
- No refunds for missed days.

Call 805-222-3990 or email [greenhorseclub@abc.com](mailto:greenhorseclub@abc.com) to save your spot!

- ① 6세에서 10세의 어린이를 대상으로 한다.
- ② 실내 및 실외 시설에서 말을 타는 법을 배울 것이다.
- ③ 추가 요금 지불 시 오후 5시까지 선택 활동을 이용할 수 있다.
- ④ 참가자는 점심 도시락을 가져와야 한다.
- ⑤ 기별 비용과 별도로 250달러의 등록비가 있다.

## 11

Smart Automatic Pet Feeder에 관한 다음 안내문의 내용과 일치하는 것은?

25007-0211

### Smart Automatic Pet Feeder User Manual

This automatic pet feeder is designed to help you feed your pet at specific times. It is for indoor household use only.

#### Filling the Food Compartment

1. Slide the food compartment upwards to remove it, without pressing or twisting it.
2. Fill the compartment with pet food and slide the food compartment back into place.

#### Managing Mealtime

1. Press the SET button. Use the arrow keys to select the desired feeding time.
2. Press SET again to save.
3. Repeat the steps to set additional mealtimes. Up to 4 mealtimes can be set for one day.

#### Recording a Personal Voice Message

1. Press and hold the REC button.
2. Speak into the Recording Port and record your message. Personal voice messages can be up to 10 seconds.
3. Release the REC button.

#### Precautions

- Do not use wet food.
- The food tray and food compartment can be removed and handwashed but should not be cleaned in dishwashers.

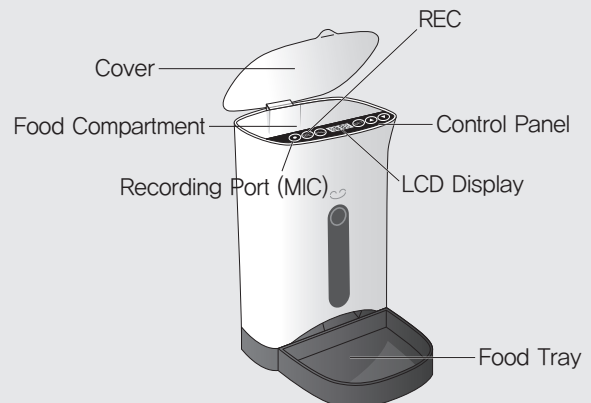

\* compartment: 통, 칸

- ① 실외에서도 사용 가능하다.
- ② 사료 통을 분리하려면 한번 누른 후 위로 밀어 올린다.
- ③ 식사 시간을 하루에 최대 세 번까지 설정할 수 있다.
- ④ 개인 음성 메시지는 최대 10초까지 녹음할 수 있다.
- ⑤ 사료 트레이는 식기세척기로 세척 가능하다.

## 12 다음 글의 밑줄 친 부분 중, 어법상 틀린 것은?

25007-0212

For livestock, researchers are typically measuring temperament traits in groups of animals on experimental or commercial farms. Compared to a more controlled experimental laboratory environment, these environments offer both opportunities and constraints to ① measuring and understanding temperament traits. Farms are a source of large numbers of animals whose pedigree links with others on the farm and elsewhere ② are frequently known. Within any given farm, animals may also have experienced a fairly standardized rearing process. However, one farm differs from another in many respects, such as the quality of human interaction, the level of nutrition provided, and the social groups the animals are kept in, among others, all of ③ them could affect temperament. For instance, ④ to assess aggressiveness in individual pigs when groups of pigs are mixed with others, a test must be used in which all animals are mixed with a standardized number of unfamiliar animals, within a controlled weight range, and into pens of the same size. Such standardization can be achieved only on some farms. All of these factors mean ⑤ that farms cannot be treated as statistical replicates, and each farm must be regarded as unique.

\* temperament: 기질 \*\* pedigree: 혈통 \*\*\* replicate: 복제본, 반복되는 것

### 13 다음 글의 밑줄 친 부분 중, 문맥상 낱말의 쓰임이 적절하지 않은 것은?

25007-0213

Storing and retrieving information is so key to survival that nature has evolved thousands of techniques to do so. For instance, Venus flytraps can ① count. To make sure that their traps don't get sprung with a single raindrop, they require three touches to a trap within a certain short period before they expend the energy needed to ② close. Thus, they must be able to count the touches as well as ③ store the time interval between them. We actually know how this is done. When a trap is touched, some calcium is released by the plant, which slowly — over seconds — dissipates. Subsequent touches ④ accumulate more calcium, and if it hits a certain threshold, the trap snaps shut. Since the calcium is constantly dissipating, the ⑤ sequential touches have to be within a certain time window to hit the threshold. This capability is clearly encoded in DNA somewhere, but again, information is being acted upon with hardly any cognition.

\* Venus flytrap: 파리지옥(빛을 달아 곤충을 잡아먹는 식충 식물) \*\* dissipate: 소멸되다  
\*\*\* threshold: 임계치

## 14 다음 빈칸에 들어갈 말로 가장 적절한 것은?

25007-0214

Philosopher of science Hans Reichenbach and others use the colour of crows to illustrate why inference based upon hypothesis tests cannot demonstrate with certainty that a circumstance always occurs. Consider the hypothesis that ‘all crows are black’. Even if one has seen a million black crows and never seen a crow of another colour, there is no guarantee that the next crow will be black. Even if one thinks one has seen every crow, one may be mistaken. Furthermore, one cannot see every future or past crow. Thus, no matter how many crows have been studied, even if all of them have been consistent with the hypothesis that all crows are black, there is no way to be certain, to prove, that all crows are black. Given the many crows I have seen and heard about, I am confident the great majority of crows are black, but I do not know for a fact that all crows are black. This is the inherent \_\_\_\_\_ of inductive reasoning.

- ① flexibility
- ② limitation
- ③ inclusivity
- ④ practicality
- ⑤ intentionality

**15** 다음 빈칸에 들어갈 말로 가장 적절한 것은?

25007-0215

Our pets are very different from wild animals; millennia of domestication have changed them almost beyond recognition from their wild ancestors. But not completely. At least with dogs and cats we can sit down, observe, and interact with them, and they are happy for us to observe and interact. Real communication with our pets is not about teaching them human words ('sit', 'lie down', 'drop it'); real communication is about \_\_\_\_\_. If you forget about any intention to train your dog to 'sit', what do you see when you spend time with him? Very much what you would see were you to spend time with a pack of wolves. Behaviours like expressing annoyance (perhaps just getting up and moving to another spot in the room) or expressing a desire for social interaction (licking your hand or lying next to you). These concepts are the true vocabulary of animals — not words and sentences — and the more you spend time with your animals, the more of this true vocabulary you will notice.

- ① observing the animal in them
- ② recognizing them as human beings
- ③ restoring and testing their wildness
- ④ maximizing their intellectual potential
- ⑤ making them understand nonverbal signals

## 16 다음 빈칸에 들어갈 말로 가장 적절한 것은?

25007-0216

Dias & Ressler conducted an experiment with mice where they trained male mice to be afraid of the scent of cherry blossoms. Every time they introduced the smell of cherry blossoms, they would electrocute the mice. Three days later, they had the mice mate with female mice. The resultant pups were not electrocuted or introduced to the scent of cherry blossoms until adulthood. When they eventually introduced the offspring to the scent of cherry blossoms, the pups started shaking and displaying other symptoms of anxiety. These pups could also pick up subtle traces of cherry blossoms in the air, which changed the structure of their brains and certain areas lit up when monitored digitally. This same behaviour was observed in the following generation of the mice even though they had never been electrocuted. This led researchers to understand how we, as humans, \_\_\_\_\_.

\* electrocute: 전기 충격을 가하다 \*\* pup: (여러 동물들의) 새끼

- ① share relatively limited evolutionary similarities with other animals
- ② devise specialized treatments to address specific medical conditions
- ③ evolve and adapt by unlocking the amazing capabilities within our genes
- ④ carry our ancestors' emotional reactions to traumatic situations and events
- ⑤ develop emotional traits through environmental influences, not through heredity

## 17 다음 빈칸에 들어갈 말로 가장 적절한 것은?

25007-0217

In many cases, information about a target location is stored in one's long-term memory. Such information is more likely to involve an association of a target to a particular landmark than an association of a target to a particular viewer position. For example, a frequent location of one's keys may be on the chest of drawers near the door. However, the viewer probably does not have a habitual location relative to the chest, so obtaining the keys involves knowing the position of the keys relative to the chest as well as one's own position relative to that chest. Of course, in some cases, a person does have a habitual position relative to a landmark in a certain spatial context and that position is directly associated with the target object. For example, in a kitchen, the chef may have a habitual location relative to the stove, and the condiments may be in a specific location relative to that stove. In this context, \_\_\_\_\_, and an inference about the relation of the condiments to the self via the stove will not be necessary.

\* condiment: (보통 복수로) 조미료, 양념

- ① a viewer's position may well change
- ② ego-centered coding will be sufficient
- ③ the location of a specific landmark is given
- ④ the habitual location is stored in short-term memory
- ⑤ knowing the spatial arrangement might be inadequate

## 18 다음 글에서 전체 흐름과 관계 없는 문장은?

25007-0218

Tough times and changing market conditions can severely affect the performance and survival of enterprises. Some enterprises view tough times as an opportunity to strengthen their businesses. ① Therefore, they try to establish their advantage over their competitors by investing aggressively in marketing activities, research and development, and developing new products, whereas some enterprises cut their marketing expenditures and wait for the recession to pass. ② In challenging times, the most frequent response of enterprises to a recession is retrenchment of marketing investments in order to survive until the economy recovers. ③ Reducing the marketing expenses such as advertising and communication may give short-term relief to the enterprise. ④ The use of social media for advertising during a recession can enhance customer independence, enabling them to exercise their free will in purchasing products. ⑤ However, in the long run, enterprises may risk losing their customer base and market share.

\* expenditure: 지출 \*\* recession: 불황 \*\*\* retrenchment: 삭감

## 19 주어진 글 다음에 이어질 글의 순서로 가장 적절한 것은?

25007-0219

In the case of self-driving cars that get into an accident, we are dealing with the following phenomenon: In the situation immediately before the accident, no more decisions can be made.

- (A) This would not, however, lead to self-driving vehicles acquiring the status of “moral agents.” Their behavior would not be considered an action in the sense of a result of genuine decision-making. An autonomous vehicle merely implements the rules programmed into its software.
- (B) The decision about the behavior of an autonomous car was made when a decision was made about its programming. This can be a lengthy process involving both the creation of appropriate legal regulations and their implementation by the manufacturer down to the individual programmer. Now, in addition to attempts to program machines to apply certain moral theories to particular situations, there are also those that aim to mimic human judgment as best as possible.
- (C) This is also true when forms of self-learning Artificial Intelligence are used. Here, too, humans will select the training examples and decide what the correct answer is in each case. They decide what the program should “learn” and when it has “learned” enough.

\* autonomous: 자율적인 \*\* mimic: 모방하다

① (A) - (C) - (B)

② (B) - (A) - (C)

③ (B) - (C) - (A)

④ (C) - (A) - (B)

⑤ (C) - (B) - (A)

## 20 주어진 글 다음에 이어질 글의 순서로 가장 적절한 것은?

25007-0220

Multiculturalism is an ideology advocating that society should consist of, or at least allow and include, distinct cultural and religious groups, with fairness. Some countries have official multiculturalism policies aimed at preserving the cultural identities of immigrant groups.

- (A) Which term is used depends on what language is spoken by the people. For example, English-speaking European researchers usually use the term multicultural, while non-English-speaking researchers use the term intercultural. It is also argued that multicultural describes the nature of the society whose members are from different ethnic and religious groups, while intercultural describes their interactions, negotiations, and processes.
- (B) In this context, multiculturalism advocates a society that extends fairness to distinct cultural and religious groups, no one culture predominating. However, the term is more commonly used to describe a society consisting of minority immigrant cultures existing alongside a predominant, indigenous culture. Often, multiculturalism is interchangeably used with the term *interculturalism*.
- (C) Another view is that intercultural refers to two culturally different groups of people, and multicultural refers to more than two culturally different groups of people. Therefore, the term multicultural is acceptable when referring to multiple cultures.

\* predominate: 우위를 차지하다 \*\* indigenous: 토착의

① (A) - (C) - (B)

② (B) - (A) - (C)

③ (B) - (C) - (A)

④ (C) - (A) - (B)

⑤ (C) - (B) - (A)

## 21 글의 흐름으로 보아, 주어진 문장이 들어가기에 가장 적절한 곳은?

25007-0221

Clearly, by the light of our current knowledge, most of what people in the past thought they knew was false.

Looking at science's history suggests that the answer to the question, what is this thing called science, is that there is no single thing called science. Science is certainly not a unified and continuous body of beliefs. ( ① ) Neither is it captured by a single scientific method. ( ② ) If we want to understand what science is — the different ways knowledge has been produced both now and in the past, and how different peoples and cultures have come to hold the beliefs they have about the natural world — we simply have no choice but to look at history. ( ③ ) To do this successfully, we need to overcome that modern condescension for the past that is often particularly prevalent in the history of science. ( ④ ) It is worth remembering, though, that by the same pessimistic induction, most of what we think we know now will turn out to be wrong by the future's standards. ( ⑤ ) The history of science should not be a game of rewarding winners and losers in the past.

\* condescension: 우월감

## 22

글의 흐름으로 보아, 주어진 문장이 들어가기에 가장 적절한 곳은?

25007-0222

A work must be “fixed in a tangible medium of expression,” to quote U.S. copyright law, to qualify for copyright protection.

Generally a work is eligible for copyright protection if it is “original,” that is, it contains markers of creative decision making by the author or artists. Something raw or common like an alphabetical listing of names would not be eligible for copyright protection. ( ① ) But a song melody that used an alphabetical list of names as lyrics would be. ( ② ) This means that if I stand up in public and speak a poem into the air, it does not enjoy copyright protection. ( ③ ) But if I record the sound of speaking it into the air or I type the poem out on a keyboard into a computer hard drive, it immediately enjoys protection. ( ④ ) My computer hard drive is a “tangible medium of expression.” ( ⑤ ) So are film, photographic paper, concrete, cloth, and the huge slabs of steel that the sculptor Richard Serra uses to make his sculptures.

\* tangible: 유형(有形)의 \*\* eligible: 자격이 있는 \*\*\* slab: 평판

23

다음 글의 내용을 한 문장으로 요약하고자 한다. 빈칸 (A), (B)에 들어갈 말로 가장 적절한 것은?

25007-0223

You might think that one reason that some individuals are successful at recognizing others' emotions from their facial expressions is because they typically show emotions clearly on their own faces. Surprisingly, though, research findings related to this idea are mixed. A review of available evidence indicates that both reading and expressing emotions are related but only when individuals are *trying* to communicate their feelings to others. When these expressions occur spontaneously — for instance, an expression of joy when something wonderful suddenly happens — then being able to recognize others' facial expressions and displaying those cues clearly oneself are *not* related. To put it in other terms, people who express their emotions openly and easily are not necessarily accurate at recognizing the facial expressions of others. Accuracy appears to be tied to people's intentional focus on showing their own emotions in their facial expressions. Perhaps they gain greater insight into the nature of others' expressions by doing so, and this helps them to recognize others' underlying feelings more accurately.



Research findings show that one's tendency to clearly convey their own emotions through facial expressions doesn't necessarily \_\_\_ (A) \_\_\_ an accurate reading of others' emotions, as the accuracy of reading seems to be linked to the \_\_\_ (B) \_\_\_ display of one's own emotions.

- | (A)         | (B)           |
|-------------|---------------|
| ① guarantee | private       |
| ② guarantee | deliberate    |
| ③ prevent   | unintentional |
| ④ generate  | frequent      |
| ⑤ prevent   | exaggerated   |

[24~25] 다음 글을 읽고, 물음에 답하시오.

If you look at mammals, the (a) larger the animal, generally speaking, the longer its life span. This makes evolutionary sense. A small animal is more (b) vulnerable to predators, and there would be no point in having a long life span if it is going to be eaten long before it dies of old age. But the more fundamental reason for the relationship between size and life span is that size is related to metabolic rate, which is roughly the rate at which an animal burns fuel in the form of food to provide the energy it needs to function. Small mammals have more surface area for their size and so (c) lose heat more easily. To compensate, they need to generate more heat, which means maintaining a (d) higher metabolic rate and eating more for their weight. This means that the total number of calories burned per hour by an animal increases more slowly than the mass of the animal. An animal that is ten times as large burns only four to five times as many calories per hour. So for their weight, smaller animals burn (e) fewer calories than larger animals. The relationship between how fast an animal burns calories and its mass is named Kleiber's law after Max Kleiber, who showed in the 1930s that an animal's metabolic rate scales to the  $3/4$  power of its mass. The exact power is a matter of dispute and some show that for mammals, a  $2/3$  power fits the data better.

\* power: 제곱

**24** 위글의 제목으로 가장 적절한 것은?

25007-0224

- ① Survival Strategies of Small Mammals
- ② Size Variation: Evidence of Genetic Diversity
- ③ Life Span: An Indicator of Successful Adaptation
- ④ Different Food Types, Different Amount of Calories
- ⑤ Size Matters When It Comes to the Life Span of Animals

**25** 밑줄 친 (a)~(e) 중에서 문맥상 낱말의 쓰임이 적절하지 않은 것은?

25007-0225

- ① (a)
- ② (b)
- ③ (c)
- ④ (d)
- ⑤ (e)

[26~28] 다음 글을 읽고, 물음에 답하십시오.

(A)

Larry's little brother had a lot to live up to. Larry was the star basketball player in the family. Though he was only five feet eight, Larry had a miraculous ability. College scouts were struck by his jaw-dropping play. Larry's brother was a year younger, even shorter, and not nearly as good. Larry always won their endless games of horse and one-on-one, and that was okay for his hero-worshipping brother. But it also drove the kid to push (a) himself harder to up his game.

\* horse: 호스(농구 슈팅 게임)

(B)

He was devastated, but this failure caused him to work harder until the next year, when he got the privilege of riding the bench while Larry starred on the court. Then Larry's kid brother miraculously grew five inches between (b) his sophomore and junior year. He went on to be a McDonald's High School All-American, and he led his college team to the NCAA national championship, his Chicago Bulls to six NBA titles, and the US Olympic team to gold. (c) He set more individual records than any other player. Larry's kid brother was worth a cool \$1.31 billion.

\* sophomore: 2학년(의)

(C)

We sometimes forget that Larry Jordan's brother has also made his share of errors on and off the court. Michael famously confessed in a CBS interview, "I've missed more than nine thousand shots in my career. I've lost almost three hundred games. Twenty-six times, I've been trusted to take the game-winning shot and missed." He will also tell you that, inch for inch, he is the second-best player in his family. He says, "When you say 'Air Jordan,' I'm number two, (d) he's one."

(D)

Just before the skinny boy's sophomore year, the coach invited him to join his older brother at a basketball camp. He figured that Larry's DNA must be in his little brother. The coach was disappointed. He admired the kid's raw speed and developing skills but figured that (e) he was destined to remain small like the rest of his family. When the coach announced the varsity roster, all of the kid's friends who were six feet or taller were chosen. But Larry's brother was cut.

\* varsity: 대표팀 \*\* roster: 명단

**26** 주어진 글 (A)에 이어질 내용을 순서에 맞게 배열한 것으로 가장 적절한 것은?

25007-0226

- ① (B) - (D) - (C)                      ② (C) - (B) - (D)                      ③ (C) - (D) - (B)  
 ④ (D) - (B) - (C)                      ⑤ (D) - (C) - (B)

**27** 밑줄 친 (a)~(e) 중에서 가리키는 대상이 나머지 넷과 다른 것은?

25007-0227

- ① (a)                      ② (b)                      ③ (c)                      ④ (d)                      ⑤ (e)

**28** 밑글에 관한 내용으로 적절하지 않은 것은?

25007-0228

- ① Larry에게는 한 살 어린 남동생이 있었다.  
 ② Larry의 남동생은 미국 올림픽 팀을 금메달로 이끌었다.  
 ③ Larry의 남동생은 자신을 가족 중 두 번째로 가장 훌륭한 선수라고 말했다.  
 ④ Larry의 남동생은 학교 농구 캠프에 참가했다.  
 ⑤ Larry의 남동생은 코치가 발표한 대표팀에 선발되었다.

# 한눈에 보는 정답

## 틀리기 쉬운 유형편

Exercise	1	2	3	4	5	6	7	8	9	10	11	12
강 01	②	③	③	①	④	⑤	④	②	①	①	①	④
02	①	③	④	①	①	⑤	⑤	⑤	④	⑤	②	④
03	②	②	④	①	①	②	②	③	①	①	②	⑤
04	①	③	①	①	①	⑤	③	④	⑤	②	④	⑤
05	②	①	⑤	①	④	④	④	①	④	③	④	⑤
06	④	⑤	④	①	④	②	⑤	③	⑤	⑤	②	③
07	⑤	⑤	④	③	④	④	④	⑤	④	③	④	②
08	④	④	⑤	⑤	③	⑤	⑤	③	⑤	③	③	②
09	③	③	④	①	④	③	③	⑤	②	③	④	⑤
10	⑤	⑤	①	③	①	③	②	⑤	②	④	⑤	⑤
11	⑤	④	①	③	③	④	④	②	③	④	②	⑤
12	④	③	④	③	③	⑤	④	②	②	④	①	⑤

Mini Test

Mini Test 1	01	02	03	04	05	06	07	08	09	10
	⑤	④	⑤	⑤	⑤	⑤	⑤	③	③	⑤
	11	12	13	14	15	16	17	18	19	20
	⑤	④	④	②	⑤	①	②	③	②	③
	21	22	23	24	25	26	27	28		
②	④	①	⑤	④	④	②	③			
Mini Test 2	01	02	03	04	05	06	07	08	09	10
	⑤	②	④	⑤	②	③	④	⑤	④	④
	11	12	13	14	15	16	17	18	19	20
	③	④	⑤	④	①	②	⑤	④	④	②
	21	22	23	24	25	26	27	28		
⑤	⑤	①	④	⑤	④	⑤	⑤			
Mini Test 3	01	02	03	04	05	06	07	08	09	10
	②	④	②	③	⑤	⑤	②	④	⑤	⑤
	11	12	13	14	15	16	17	18	19	20
	④	③	④	②	①	④	②	④	②	②
	21	22	23	24	25	26	27	28		
④	②	②	⑤	⑤	④	④	⑤			

# 고1~2, 내신 중점

구분	고교 입문	기초	기본	특화	단기	
국어	고등예비과정	윤혜정의 개념의 나비효과 입문편 + 워크북	기본서 올림포스	국어 특화 국어 독해의 원리	단기 특강	
		어휘가 독해다! 수능 국어 어휘	—	국어 문법의 원리		
영어		정승익의 수능 개념 잡는 대박구문	올림포스 전국연합 학력평가 기출문제집	영어 특화 Grammar POWER Reading POWER		Listening POWER Voca POWER
		주혜연의 해석공식 논리 구조편	—	영어 특화 고급영어독해		
수학		기초 50일 수학 + 기출 워크북	유형서 올림포스 유형편	고급 올림포스 고난도		
		매스 디렉터의 고1 수학 개념 끝장내기	수학 특화 수학의 왕도			
한국사 사회		기본서 개념완성	고등학생을 위한 다담은 한국사 연표			
과학		50일 과학	개념완성 문항편	인공지능 수학과 함께하는 고교 AI 입문 수학과 함께하는 AI 기초		

과목	시리즈명	특징	난이도	권장 학년
전 과목	고등예비과정	예비 고등학생을 위한 과목별 단기 완성		예비 고1
	내 등급은?	고1 첫 학력평가 + 반 배치고사 대비 모의고사		예비 고1
국/영/수	올림포스	내신과 수능 대비 EBS 대표 국어·수학·영어 기본서		고1~2
	올림포스 전국연합학력평가 기출문제집	전국연합학력평가 문제 + 개념 기본서		고1~2
	단기 특강	단기간에 끝내는 유형별 문항 연습		고1~2
한/사/과	개념완성&개념완성 문항편	개념 한 권 + 문항 한 권으로 끝내는 한국사·탐구 기본서		고1~2
국어	윤혜정의 개념의 나비효과 입문 편 + 워크북	윤혜정 선생님과 함께 시작하는 국어 공부의 첫걸음		예비 고1~고2
	어휘가 독해다! 수능 국어 어휘	학평·모평·수능 출제 필수 어휘 학습		예비 고1~고2
	국어 독해의 원리	내신과 수능 대비 문학·독서(비문학) 특화서		고1~2
	국어 문법의 원리	필수 개념과 필수 문항의 언어(문법) 특화서		고1~2
영어	정승익의 수능 개념 잡는 대박구문	정승익 선생님과 CODE로 이해하는 영어 구문		예비 고1~고2
	주혜연의 해석공식 논리 구조편	주혜연 선생님과 함께하는 유형별 지문 독해		예비 고1~고2
	Grammar POWER	구문 분석 트리로 이해하는 영어 문법 특화서		고1~2
	Reading POWER	수준과 학습 목적에 따라 선택하는 영어 독해 특화서		고1~2
	Listening POWER	유형 연습과 모의고사·수행평가 대비 올인원 듣기 특화서		고1~2
	Voca POWER	영어 교육과정 필수 어휘와 어원별 어휘 학습		고1~2
수학	고급영어독해	영어 독해력을 높이는 영미 문학/비문학 읽기		고2~3
	50일 수학 + 기출 워크북	50일 만에 완성하는 초·중·고 수학의 맥		예비 고1~고2
	매스 디렉터의 고1 수학 개념 끝장내기	스타강사 강의, 손글씨 풀이와 함께 고1 수학 개념 정복		예비 고1~고1
	올림포스 유형편	유형별 반복 학습을 통해 실력 잡는 수학 유형서		고1~2
	올림포스 고난도	1등급을 위한 고난도 유형 집중 연습		고1~2
	수학의 왕도	직관적 개념 설명과 세분화된 문항 수록 수학 특화서		고1~2
한국사	고등학생을 위한 다담은 한국사 연표	연표로 흐름을 잡는 한국사 학습		예비 고1~고2
과학	50일 과학	50일 만에 통합과학의 핵심 개념 완벽 이해		예비 고1~고1
기타	수학과 함께하는 고교 AI 입문/AI 기초	파이선 프로그래밍, AI 알고리즘에 필요한 수학 개념 학습		예비 고1~고2

# 고2~N수, 수능 집중

구분	수능 입문	기출/연습	연계 + 연계 보완	고난도	모의고사
국어	윤혜정의 개념/패턴의 나비효과 — 기본서 수능 빌드업	윤혜정의 기출의 나비효과 —	수능특강 문학 연계 기출 수능특강 사용설명서 —	하루 3개 1등급 국어독서 —	FINAL 실전모의고사 —
영어	수능특강 Light — 강의노트 수능 개념	수능 기출의 미래 —	수능연계교재의 VOCA 1800 수능연계 기출 Vaccine VOCA 2200 수능 영어 간접연계 서치라이트	하루 6개 1등급 영어독해 —	만점마무리 봉투모의고사 시즌1 — 만점마무리 봉투모의고사 시즌2 —
수학	수능 감(感)잡기 —	수능 기출의 미래 미니모의고사 —	수능 연계교재 수능특강   수능완성	수능연계완성 3주 특강 —	만점마무리 봉투모의고사 고난도 Hyper —
한국사 사회	수능 스타트 —	수능특강Q 미니모의고사 —	eBook 전용 수능완성R 모의고사   수능 등급을 올리는 변별 문항 공략	박봄의 사회·문화 표 분석의 패턴 —	수능 직전보강 클리어 봉투모의고사 —
과학	—	—	—	—	—

구분	시리즈명	특징	난이도	영역
수능 입문	윤혜정의 개념/패턴의 나비효과	윤혜정 선생님과 함께하는 수능 국어 개념/패턴 학습	<input type="checkbox"/>	국어
	수능 빌드업	개념부터 문항까지 한 권으로 시작하는 수능 특화 기본서	<input type="checkbox"/>	국/수/영
	수능 스타트	2028학년도 수능 예시 문항 분석과 문항 연습	<input type="checkbox"/>	사/과
	수능 감(感)잡기	동일 소재·유형의 내신과 수능 문항 비교로 수능 입문	<input type="checkbox"/>	국/수/영
	수능특강 Light	수능 연계교재 학습 전 가볍게 시작하는 수능 도전	<input type="checkbox"/>	영어
기출/연습	수능개념	EBS 대표 강사들과 함께하는 수능 개념 다지기	<input type="checkbox"/>	전 영역
	윤혜정의 기출의 나비효과	윤혜정 선생님과 함께하는 까다로운 국어 기출 완전 정복	<input type="checkbox"/>	국어
	수능 기출의 미래	올해 수능에 딱 필요한 문제만 선별한 기출문제집	<input type="checkbox"/>	전 영역
	수능 기출의 미래 미니모의고사	부담 없는 실전 훈련을 위한 기출 미니모의고사	<input type="checkbox"/>	국/수/영
	수능특강Q 미니모의고사	매일 15분 연계교재 우수문항 풀이 미니모의고사	<input type="checkbox"/>	국/수/영/사/과
연계 + 연계 보완	수능완성R 모의고사	과년도 수능 연계교재 수능완성 실전편 수록	<input type="checkbox"/>	수학
	수능특강	최신 수능 경향과 기출 유형을 반영한 종합 개념 학습	<input type="checkbox"/>	전 영역
	수능특강 사용설명서	수능 연계교재 수능특강의 국어·영어 지문 분석	<input type="checkbox"/>	국/영
	수능특강 문학 연계 기출	수능특강 수록 작품과 연관된 기출문제 학습	<input type="checkbox"/>	국어
	수능완성	유형·테마 학습 후 실전 모의고사로 문항 연습	<input type="checkbox"/>	전 영역
	수능완성 사용설명서	수능 연계교재 수능완성의 국어·영어 지문 분석	<input type="checkbox"/>	국/영
	수능 영어 간접연계 서치라이트	출제 가능성이 높은 핵심 간접연계 대비	<input type="checkbox"/>	영어
	수능연계교재의 VOCA 1800	수능특강과 수능완성의 필수 중요 어휘 1800개 수록	<input type="checkbox"/>	영어
고난도	수능연계 기출 Vaccine VOCA 2200	수능 - EBS 연계와 평가원 최다 빈출 어휘 선별 수록	<input type="checkbox"/>	영어
	하루 N개 1등급 국어독서/영어독해	매일 꾸준한 기출문제 학습으로 완성하는 1등급 실력	<input type="checkbox"/>	국/영
	수능연계완성 3주 특강	단기간에 끝내는 수능 1등급 변별 문항 대비	<input type="checkbox"/>	국/수/영
	박봄의 사회·문화 표 분석의 패턴	박봄 선생님과 사회·문화 표 분석 문항의 패턴 연습	<input type="checkbox"/>	사회탐구
모의고사	수능 등급을 올리는 변별 문항 공략	EBS 선생님이 직접 선별한 고변별 문항 연습	<input type="checkbox"/>	수/영
	FINAL 실전모의고사	EBS 모의고사 중 최다 분량 최다 과목 모의고사	<input type="checkbox"/>	전 영역
	만점마무리 봉투모의고사 시즌1/시즌2	실제 시험지 형태와 OMR 카드로 실전 연습 모의고사	<input type="checkbox"/>	전 영역
	만점마무리 봉투모의고사 고난도 Hyper	고난도 문항까지 국·수·영 논스톱 훈련 모의고사	<input type="checkbox"/>	국·수·영
	수능 직전보강 클리어 봉투모의고사	수능 직전 성적을 끌어올리는 마지막 모의고사	<input type="checkbox"/>	국/수/영/사/과



memo