

Preliminary

The contents of this document are confidential and must not be disclosed wholly or in part to any third part without the prior written consent of AMPIRE CO., LTD



晶采光電科技股份有限公司
AMPIRE CO., LTD.

SPECIFICATIONS FOR LCD MODULE

CUSTOMER	
CUSTOMER PART NO.	
AMPIRE PART NO.	AM240320L8TNQW-00H
APPROVED BY	
DATE	

- Approved For Specifications
 Approved For Specifications & Sample

AMPIRE CO., LTD.

**TOWER A, 4F, No.114, Sec. 1, HSIN-TAI 5th RD., HIS-CHIH,
TAIPEI HSIEN, TAIWAN(R.O.C.)**

台北縣汐止鎮新台五路一段114號4樓(東方科學園區A棟)

TEL:886-2-26967269, FAX:886-2-26967196 or 886-2-26967270

APPROVED BY	CHECKED BY	ORGANIZED BY

Preliminary

The contents of this document are confidential and must not be disclosed wholly or in part to any third part without the prior written consent of AMPIRE CO., LTD

RECORD OF REVISION

Revision Date	Page	Contents	Editor
2007/08/15	-	New Release	Emil
2007/08/21	12	Modified Interface Specification (Pin6 and Pin9).	Emil
2007/08/21	-	Issued official Part No. AM240320L8TNQW-00H	Emil
2007/08/23	36	Modified Mechanical Drawing.(To indicate Backlight Solder PAD).	Emil
2007/09/20	36	Modified Mechanical Drawing.(Remove bezel)	Emil
2007/09/27	4	Correction the Absolute max ratings of V_{LED} .	Emil

Preliminary

The contents of this document are confidential and must not be disclosed wholly or in part to any third part without the prior written consent of AMPIRE CO., LTD

1. Features

LCD 2.4 inch Amorphous-TFT-LCD (Thin Film Transistor Liquid Crystal Display) for mobile-phone or handy electrical equipments. The LCD adopts one backlight with High brightness 4-lamps white LED.

- (1) Construction: 2.4" a-Si color TFT-LCD with White LED Backlight and FPC.
- (2) LCD : 2.1 Amorphous-TFT 2.4 inch display, transmissive, Normally white type, 12 o'clock.
 - 2.2 240(RGB)X320 dots Matrix, 1/320 Duty.
 - 2.3 LCD controller is ILI9320.
 - 2.4 Real 262K colors display:
 - Red-5bit, Green-6bit, Blue-5bit (MPU8/16 mode)
 - Red-6bit, Green-6bit, Blue-6bit (MPU9/18, RGB18 mode)
- (3) Low cross talk by frame rate modulation
- (4) Direct data display with display RAM
- (5) Partial display function: You can save power by limiting the display space.
- (6) MPU interface: 8/16/18 bit parallel and 16/18-bit Serial Bus Interface Timing.
- (7) RGB interface: 16/18-bit RGB Interface Circuit Input.

Preliminary

The contents of this document are confidential and must not be disclosed wholly or in part to any third part without the prior written consent of AMPIRE CO., LTD

2. Mechanical specifications

Dimensions and weight

Item		Specifications	Unit
External shape dimensions		*1 43.6 (W) x 85.5(H) x 2.8 (TMax.)	mm
Main LCD	Pixel pitch	0.153 (W) x 0.153(H)	mm
	Active area	36.72 (W) x 48.96 (H)	mm
Weight		T.B.D.	g

*1. This specification is about External shape on shipment from AMPIRE.

3. Absolute max. ratings and environment

3.1. Absolute max ratings

Ta=25°C GND=0V

Item	Symbol	Min.	Max.	Unit	Remarks
Power Supply for Logic	VDD – GND	-0.3	+4.0	V	
Power Input Voltage	Vci	-0.3	+4.6	V	
Power Supply for LED backlight	LED A – LED K	-0.5	+15	V	
Input voltage	VIN	-0.5	VDD+0.5	V	

3.2. Environment

Item	Specifications	Remarks
Storage temperature	Max. +70 °C Min. -30 °C	Note 1: Non-condensing
Operating temperature	Max. +60 °C Min. -20 °C	Note 1: Non-condensing

Note 1 : Ta ≤ +40 °C Max.85%RH

Ta > +40 °C The max. humidity should not exceed the humidity with 40 °C
85%RH.

Preliminary

The contents of this document are confidential and must not be disclosed wholly or in part to any third part without the prior written consent of AMPIRE CO., LTD

4. Electrical specifications**4.1. Electrical characteristics of LCD**

($V_{DD}=2.8V$, $T_a=25^{\circ}C$)

Item	Symbol	Conditions	MIN.	TYP.	MAX.	Unit
IC power voltage	V_{DD}		2.4	2.8	3.3	V
Power input voltage	V_{CI}		2.5	-	3.3	V
High-level input voltage	V_{IHC}		$0.8V_{DD}$		V_{DD}	V
Low-level input voltage	V_{ILC}		0		$0.2V_{DD}$	V
Consumption current of VDD	I_{DD}		-	6	-	mA
Consumption current of LED	I_F	$V_F=12.8V$	-	20	-	mA

※ 1. 1/320 duty

Preliminary

The contents of this document are confidential and must not be disclosed wholly or in part to any third part without the prior written consent of AMPIRE CO., LTD

4.2. LED back light specification

Item	Symbol	Conditions	MIN.	TYP.	MAX.	Unit
Forward voltage	V_f	$I_f = 20\text{mA}$	12.3	12.8	13.8	V
Reverse voltage	V_r		-	-	12	V
Forward current	I_f	4-chip serial	-	20	-	mA
Power Consumption	P_{BL}	$I_f = 20\text{mA}$	-	256	276	mW
Uniformity (with L/G)	-	$I_f = 20\text{mA}$	80%*1	-	-	
Bare LED Luminous intensity	V_f I_f	13.2V 20mA	3700	-	-	cd/m ²
Luminous color	White					
Chip connection	4 chip serial connection					

LCM measure position:

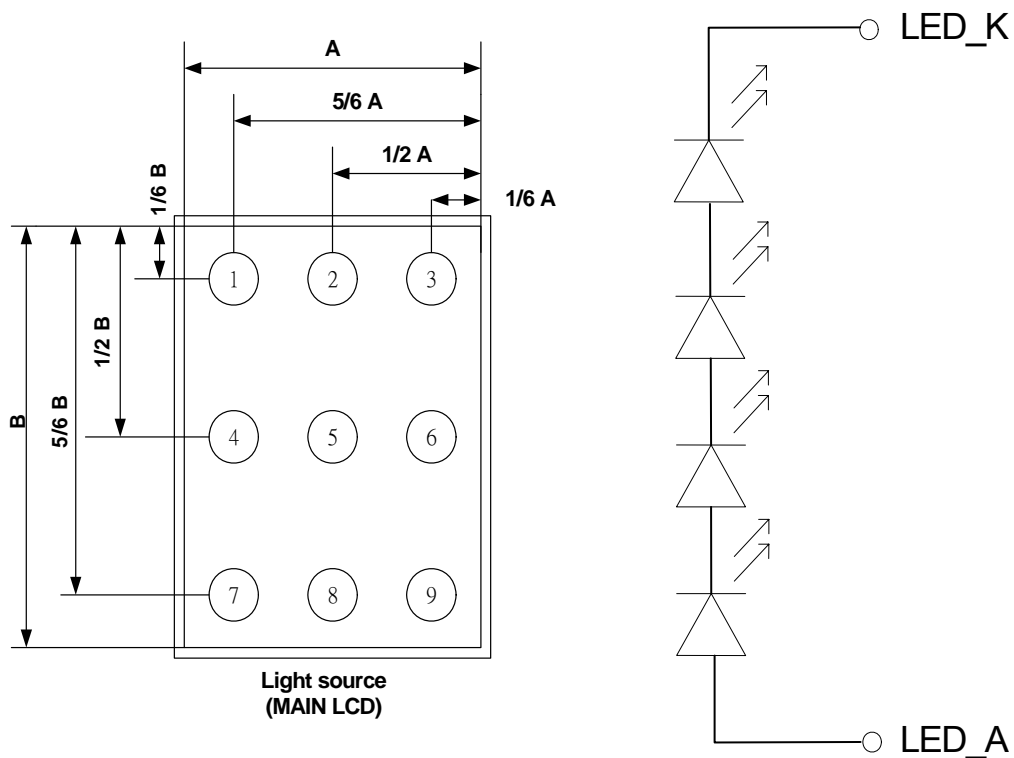

*1 Uniformity (LT): $\frac{\text{Min}(P1 \sim P9)}{\text{Max}(P1 \sim P9)} \times 100 \geq 80\%$

Preliminary

The contents of this document are confidential and must not be disclosed wholly or in part to any third part without the prior written consent of AMPIRE CO., LTD

5. Optical characteristics

5.1. Optical characteristics

(1/320 Duty in case except as specified elsewhere Ta = 25°C)

LED backlight transmissive module:

Item	Symbol	Temp.	Min.	Std.	Max.	Unit	Conditions
Response time	Tr	25°C	-	10	20	ms	$\theta = 0^\circ, \varphi = 0^\circ$ (Note 2)
	Tf	25°C	-	20	30		
Contrast ratio	CR	25°C	150	200	-	-	$\theta = 0^\circ, \varphi = 0^\circ$ LED:ON, LIGHT:OFF (Note 4)
Transmittance	T	25°C	-	4.7	-	%	
Visual angle range front and rear	θ	25°C	(θ f) 70 (θ b) 70			De- gree	$\varphi 1 = 0^\circ, \varphi = 0^\circ, CR \geq 10$ LED:ON LIGHT:OFF (Note 3)
Visual angle range left and right	θ	25°C	(θ l) 80 (θ r) 80			De- gree	$\varphi 1 = 0^\circ, \varphi = 90^\circ, CR \geq 10$ LED:ON LIGHT:OFF (Note 3)
Visual angle direction priority			12:00				(Note 5)
Brightness			170	220	-	Cd/m ²	I _F =20mA, Full White pattern

Preliminary

The contents of this document are confidential and must not be disclosed wholly or in part to any third part without the prior written consent of AMPIRE CO., LTD

5.2. CIE (x, y) chromaticity (1/320 Duty Ta = 25°C)

Main LCD: (1/320 Duty Ta = 25°C)

Item	Symbol	Transmissive			Conditions
		Min.	Std.	Max.	
Red	x	0.605	0.635	0.665	$\theta = 0^\circ, \varphi = 0^\circ$
	y	0.317	0.347	0.377	
Green	x	0.314	0.344	0.374	$\theta = 0^\circ, \varphi = 0^\circ$
	y	0.562	0.592	0.620	
Blue	x	0.129	0.159	0.189	$\theta = 0^\circ, \varphi = 0^\circ$
	y	0.132	0.162	0.192	
White	x	0.283	0.313	0.343	$\theta = 0^\circ, \varphi = 0^\circ$
	y	0.322	0.352	0.382	

Light source

Item	Symbol	Value			Conditions
		Min.	Std.	Max.	
Light source	x	0.26	0.29	0.34	$\theta = 0^\circ, \varphi = 0^\circ$
	y	0.26	0.29	0.34	
LED brightness		3700	-	-	Unit: cd/m^2 ($I_F=20\text{mA}$)

Preliminary

The contents of this document are confidential and must not be disclosed wholly or in part to any third part without the prior written consent of AMPIRE CO., LTD

NOTE 1: Optical characteristic measurement system

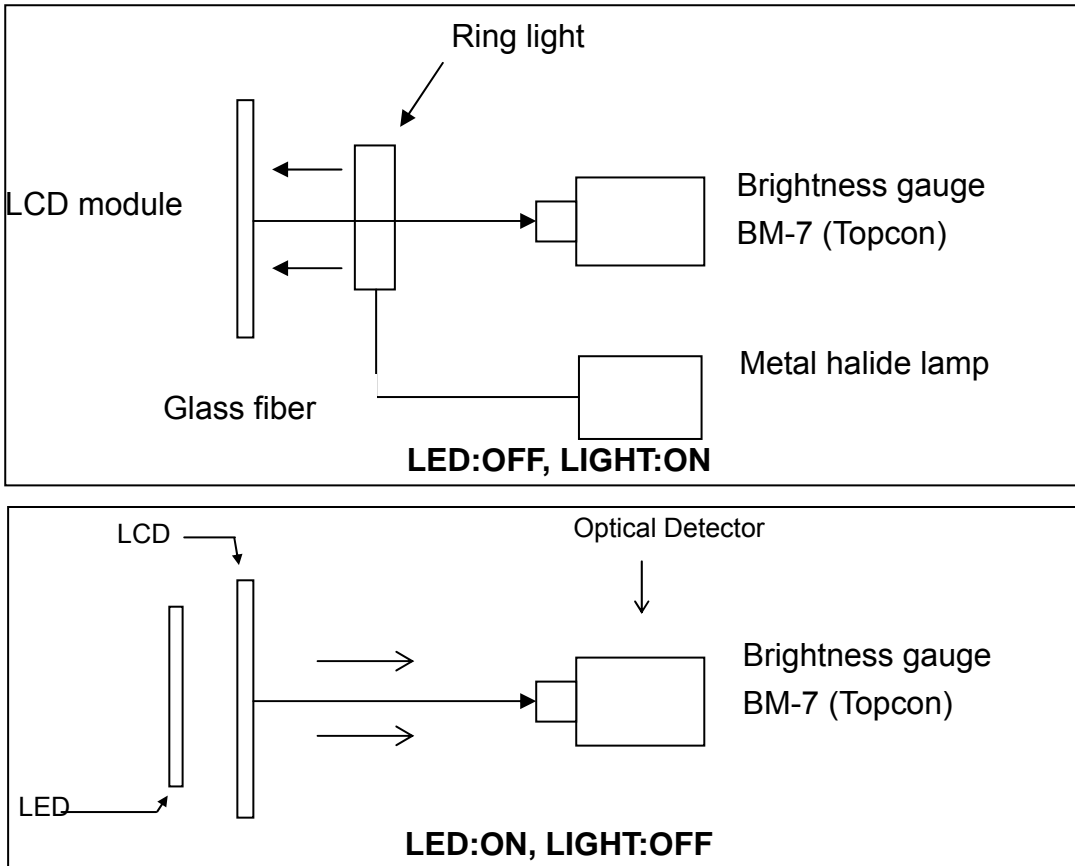

NOTE 2: Definition of Response Time : Sum of TR and TF

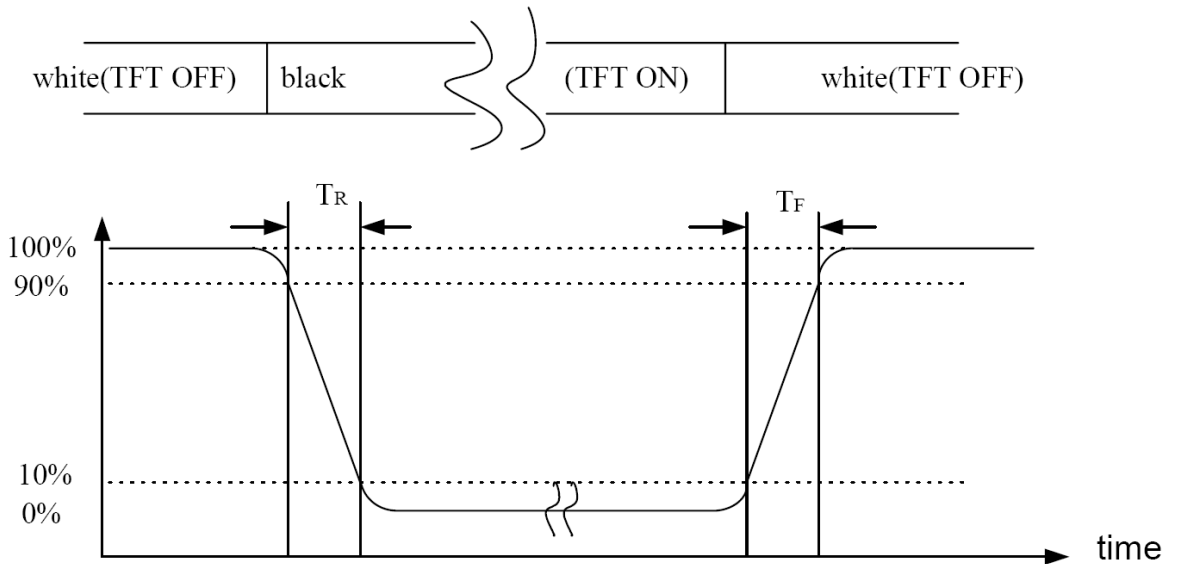

Preliminary

The contents of this document are confidential and must not be disclosed wholly or in part to any third part without the prior written consent of AMPIRE CO., LTD

NOTE 3: φ 、 θ definition

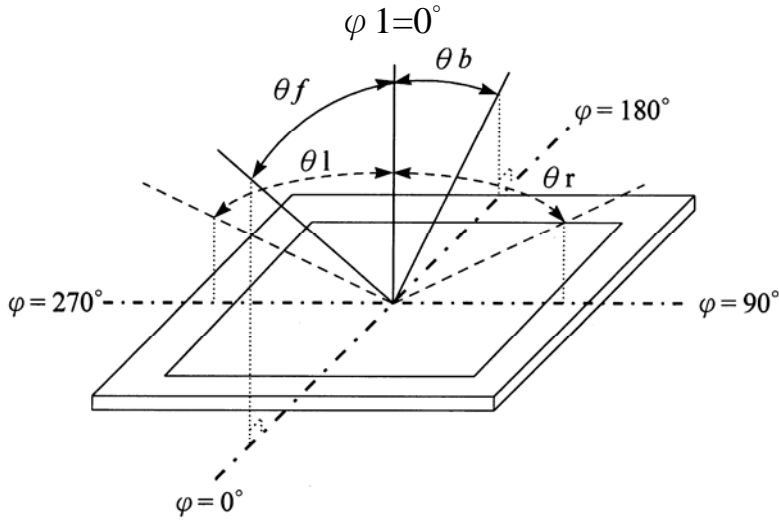

NOTE 4: Contrast definition

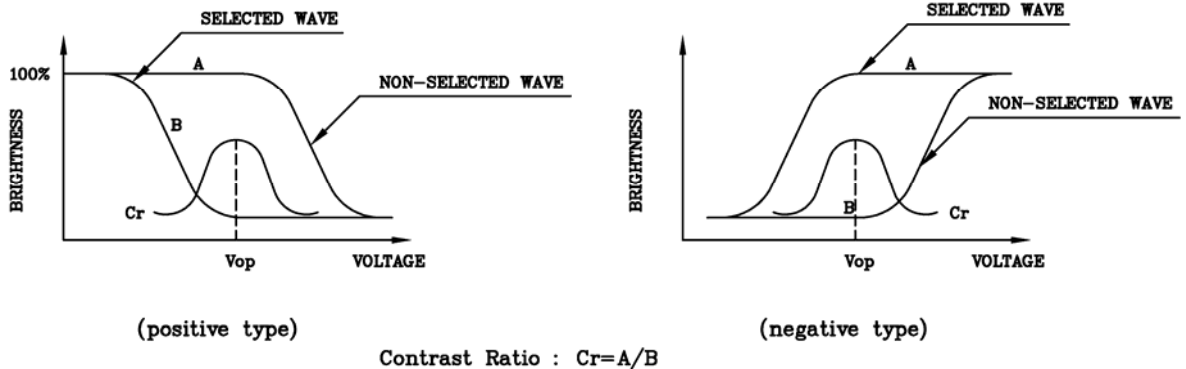

NOTE 5: Visual angle direction priority

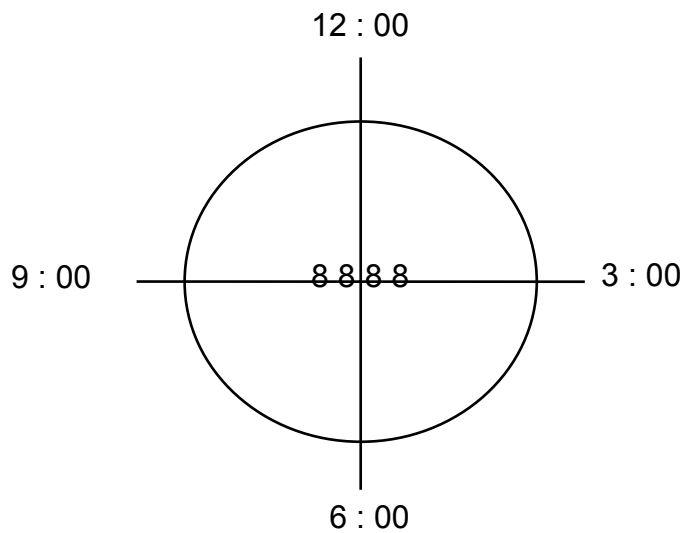

Preliminary

The contents of this document are confidential and must not be disclosed wholly or in part to any third part without the prior written consent of AMPIRE CO., LTD

6. Block Diagram

Display format: A-Si TFT transmissive, Normally white type, 12 o'clock.
Display mode: Normally white
Display composition: 240 x RGB x 320 pixels
LCD Driver : ILI9320
Back light: White LED x 4 ($I_F=20mA$)

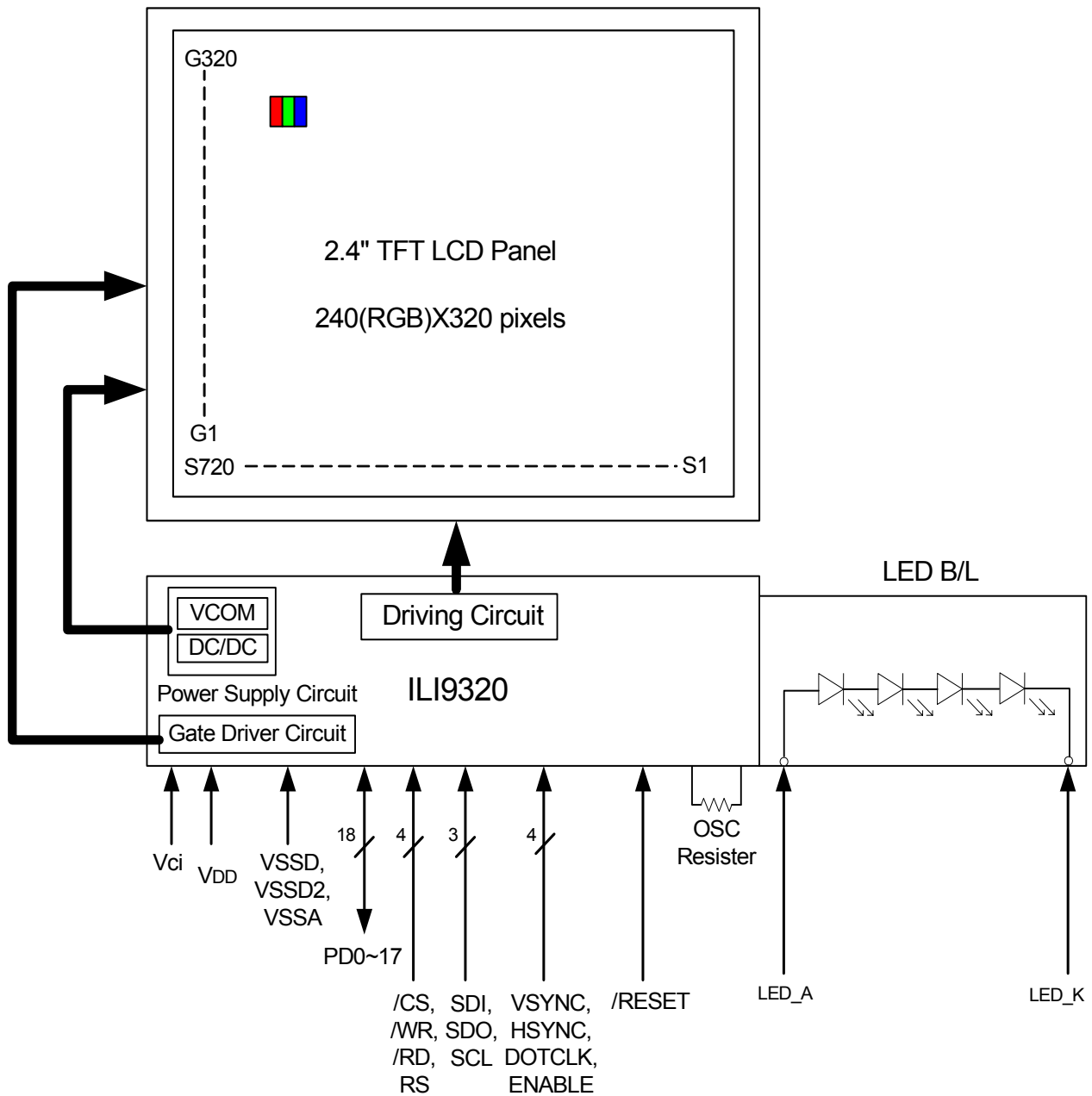

Preliminary

The contents of this document are confidential and must not be disclosed wholly or in part to any third part without the prior written consent of AMPIRE CO., LTD

7. Interface specifications

Pin No.	Terminal	Functions
1	ENABLE	A data ENABLE signal in RGB I/F mode.
2	DOTCLK	Dot clock signal in RGB I/F mode.
3	HSYNC	Frame synchronizing signal in RGB I/F mode.
4	VSYNC	Frame synchronizing signal in RGB I/F mode.
5	/CS	Chip select signal.
6	WR/SCL	Write enable signal/Serial bus interface clock input pin.
7	SDI	Serial bus interface data input pin.
8	RS	Command/display Data Selection.
9	NC	NC
10	/RD	Read enable signal.
11	/RESET	Reset pin. Setting either pin low initializes the LSI. Must be reset the chop after power being supplied.
12	PD0	18-bits Interface Circuit
13	PD1	
14	PD2	
15	PD3	
16	PD4	
17	PD5	
18	PD6	
19	PD7	
20	PD8	
21	PD9	
22	PD10	
23	PD11	
24	PD12	
25	PD13	
26	PD14	
27	PD15	
28	PD16	
29	PD17	

(To be continue)

Preliminary

The contents of this document are confidential and must not be disclosed wholly or in part to any third part without the prior written consent of AMPIRE CO., LTD

30	VDD	Power supply for the internal logic circuit. (VDD=2.2~3.3V)
31	VCI	Power supply for Step-up circuit. (VCI=2.5~3.3V)
32	VCI	
33	NC	NC
34	NC	
35	NC	
36	NC	
37	NC	
38	NC	
39	NC	
40	GND	GND-terminal
41	NC	NC
42	NC	
43	NC	
44	NC	
45	GND	GND-terminal
46	SDO	Serial bus interface data output pin.
47	NC	NC
48	NC	
49	NC	
50	GND	GND-terminal
51	GND	

Selection the System Interface mode

	IM3 (JP3)	IM2 (JP2)	IM1 (JP1)	IM0 (JP0)
18Bit	H	L	H	L
16 Bit	L	L	H	L
9 Bit	H	L	H	H
8 Bit	L	L	H	H
Serial Mode	L	H	L	L

Jumper Default: JP0= "L" JP1= "L" JP2= "H" JP3= "L"

Preliminary

The contents of this document are confidential and must not be disclosed wholly or in part to any third part without the prior written consent of AMPIRE CO., LTD

8. System interface and RGB interface

8.1. 80-system 18-bit interface

The i80/18-bit system interface is selected by setting the IM[3:0] as "1010" levels.

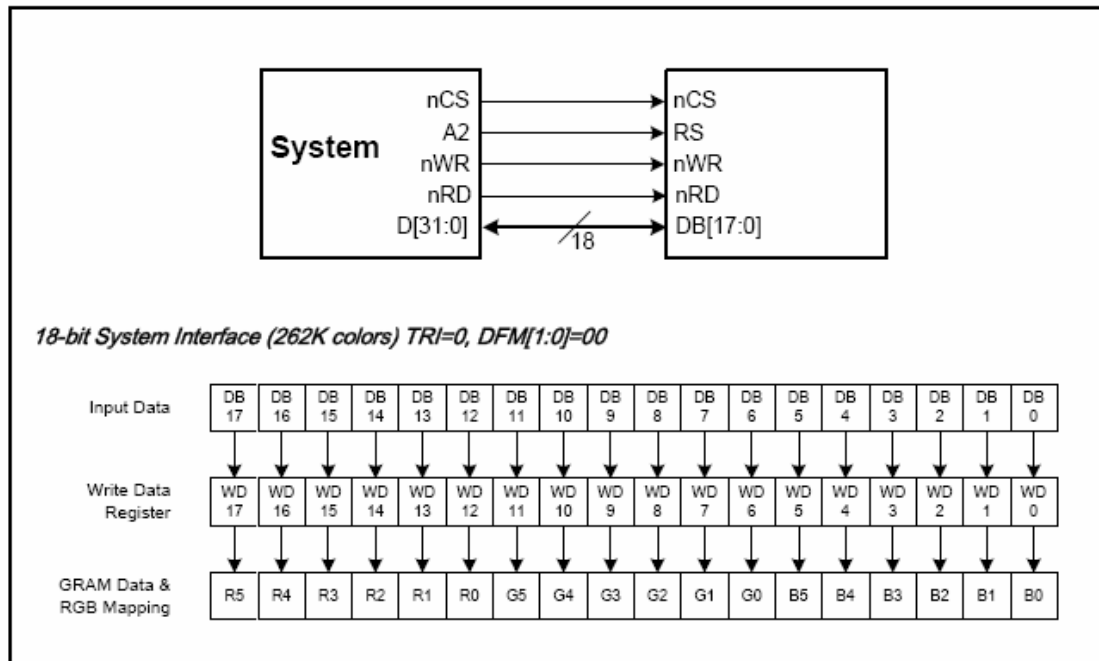

Preliminary

The contents of this document are confidential and must not be disclosed wholly or in part to any third part without the prior written consent of AMPIRE CO., LTD

8.2. 80-system 16-bit interface

The i80/16-bit system interface is selected by setting the IM[3:0] as "0010" levels. The 262K or 65K color can be display through the 16-bit MPU interface. When the 262K color is displayed, two transfers (1st transfer: 2 bits, 2nd transfer: 16 bits or 1st transfer: 16 bits, 2nd transfer: 2 bits) are necessary for the 16-bit CPU interface.

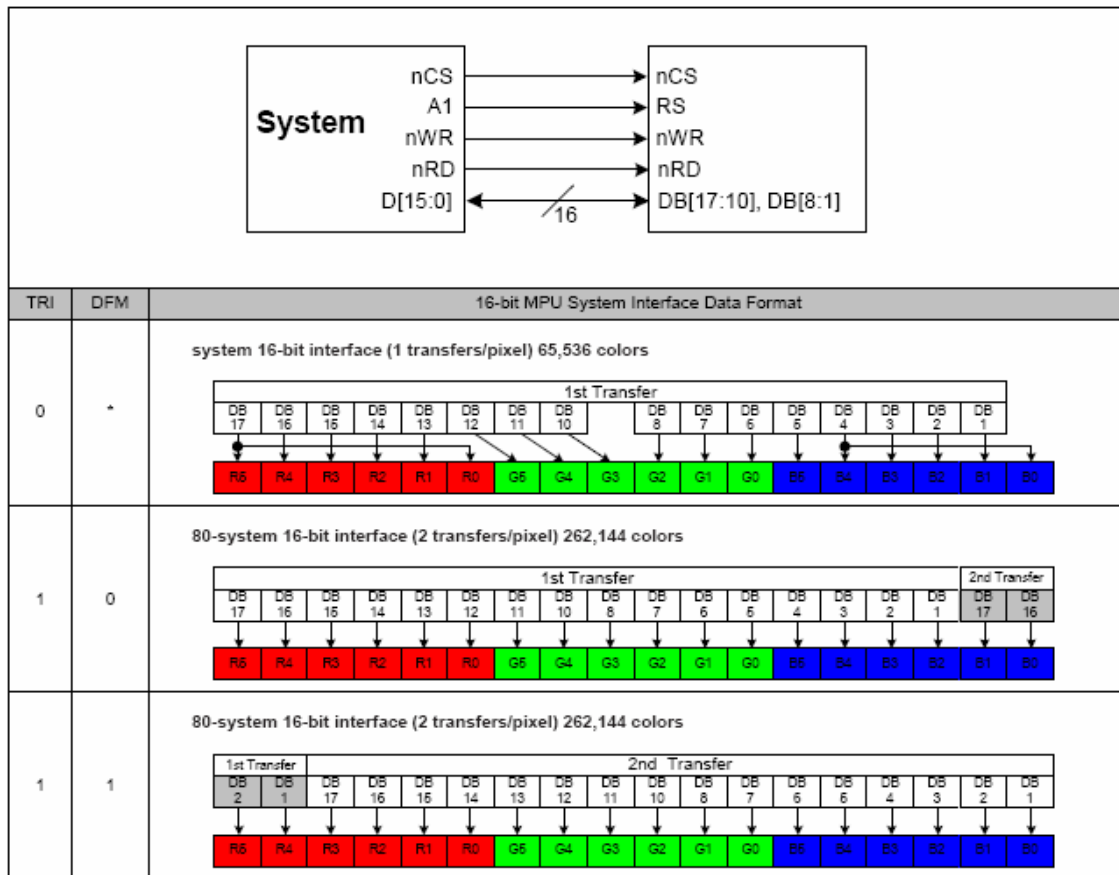

Preliminary

The contents of this document are confidential and must not be disclosed wholly or in part to any third part without the prior written consent of AMPIRE CO., LTD

8.3. 80-system 9-bit interface

The i80/9-bit system interface is selected by setting the IM[3:0] as "1011" and the DB17~DB9 pins are used to transfer the data. When writing the 16-bit register, the data is divided into upper byte (8 bits and LSB is not used) lower byte and the upper byte is transferred first. The display data is also divided in upper byte (9 bits) and lower byte, and the upper byte is transferred first. The unused DB[8:0] pins must be tied to either Vcc or AGND.

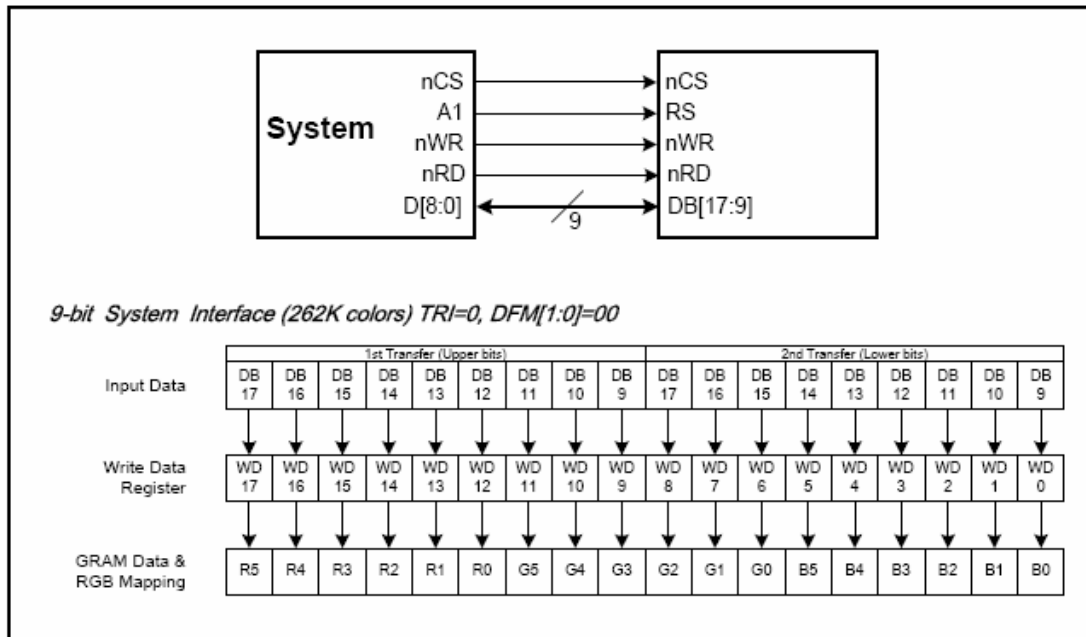

8.4. 80-system 8-bit interface

The i80/8-bit system interface is selected by setting the IM[3:0] as "0011" and the DB17~DB10 pins are used to transfer the data. When writing the 16-bit register, the data is divided into upper byte (8 bits and LSB is not used) lower byte and the upper byte is transferred first. The display data is also divided in upper byte (8 bits) and lower byte, and the upper byte is transferred first. The written data is expanded into 18 bits internally (see the figure below) and then written into GRAM. The unused DB[9:0] pins must be tied to either Vcc or AGND.

Preliminary

The contents of this document are confidential and must not be disclosed wholly or in part to any third part without the prior written consent of AMPIRE CO., LTD

TRI	DFM	8-bit MPU System Interface Data Format
0	*	<p>system 8-bit interface (2 transfers/pixel) 65,536 colors</p>
1	0	<p>80-system 8-bit interface (3 transfers/pixel) 262,144 colors</p>
1	1	<p>80-system 8-bit interface (3 transfers/pixel) 262,144 colors</p>

Data transfer synchronization in 8/9-bit bus interface mode

ILI9320 supports a data transfer synchronization function to reset upper and lower counters which count the transfers numbers of upper and lower byte in 8/9-bit interface mode. If a mismatch arises in the numbers of transfers between the upper and lower byte counters due to noise and so on, the "00" hex register is written 4 times consecutively to reset the upper and lower counters so that data transfer will restart with a transfer of upper byte. This synchronization function can effectively prevent display error if the upper/lower counters are periodically reset.

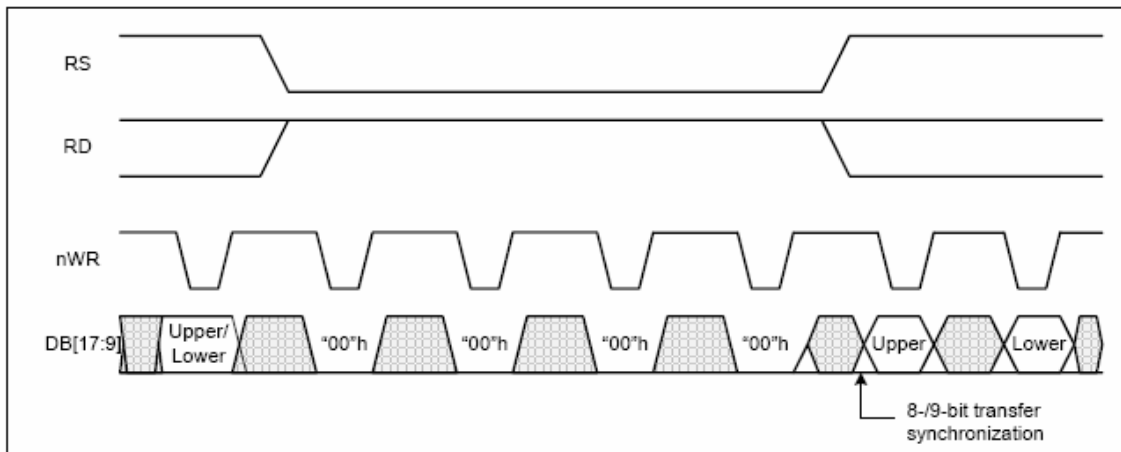

Figure6 Data Transfer Synchronization in 8/9-bit System Interface

Preliminary

The contents of this document are confidential and must not be disclosed wholly or in part to any third part without the prior written consent of AMPIRE CO., LTD

8.5. RGB interface

The RGB Interface mode is available for ILI9320 and the interface is selected by setting the RIM[1:0] bits as following table.

RIM1	RIM0	RGB Interface	DB pins
0	0	18-bit RGB Interface	DB[17:0]
0	1	16-bit RGB Interface	DB[17:13], DB[11:1]
1	0	6-bit RGB Interface	DB[17:12]
1	1	Setting prohibited	

18-bit RGB Interface (262K colors)

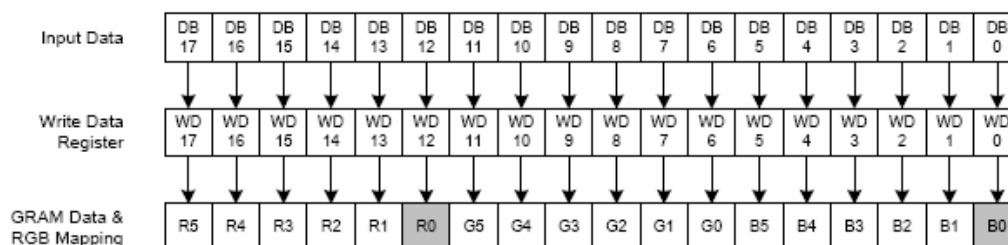

16-bit RGB Interface (65K colors)

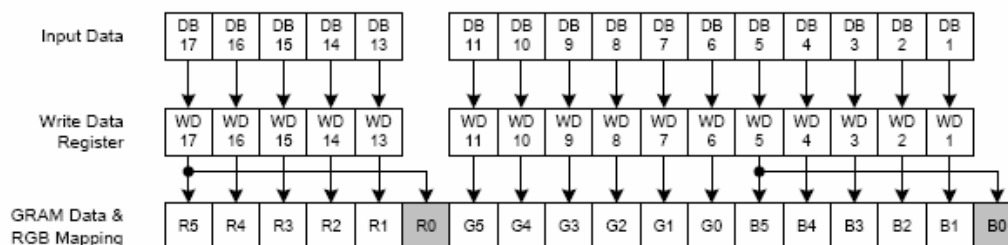

6-bit RGB Interface (262K colors)

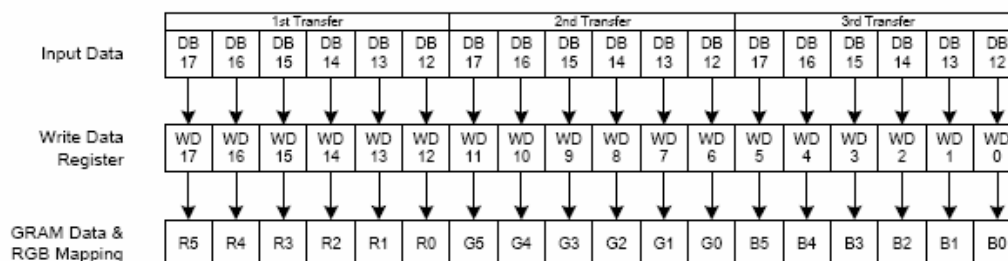

Preliminary

The contents of this document are confidential and must not be disclosed wholly or in part to any third part without the prior written consent of AMPIRE CO., LTD

8.6. Timing of System Interface and RGB Interface

a. System Interface

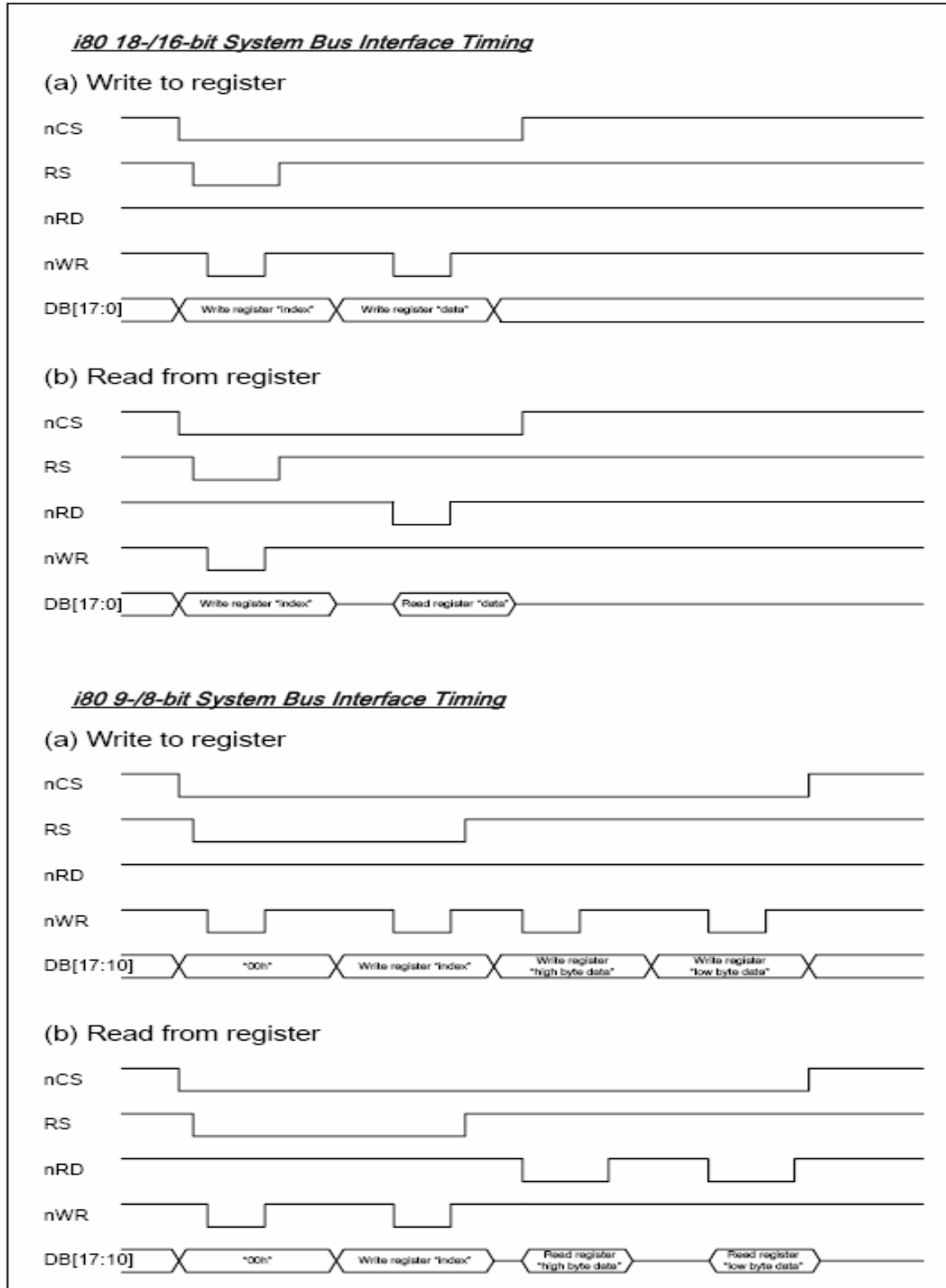

Preliminary

The contents of this document are confidential and must not be disclosed wholly or in part to any third part without the prior written consent of AMPIRE CO., LTD

b. RGB Interface

The following are diagrams of interfacing timing with LCD panel control signals in internal operation and RGB interface modes.

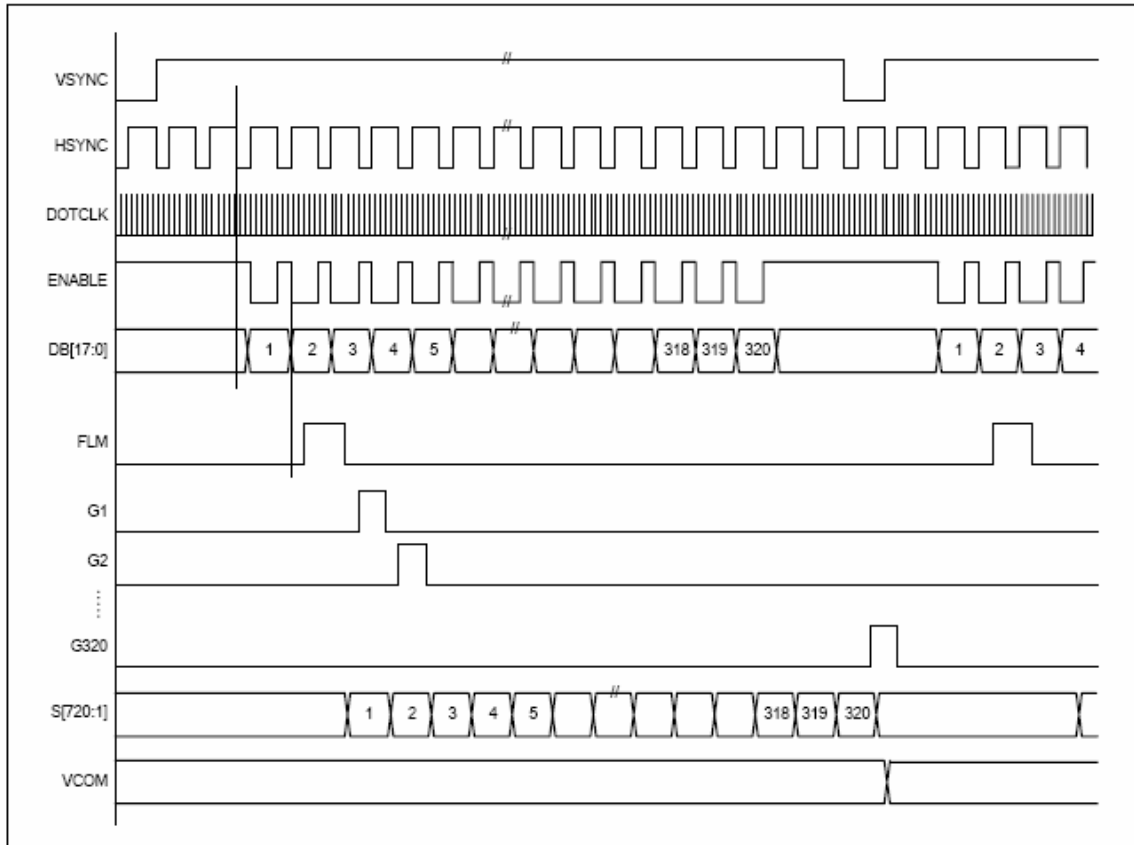

Preliminary

The contents of this document are confidential and must not be disclosed wholly or in part to any third part without the prior written consent of AMPIRE CO., LTD

9. INSTRUCTION DESCRIPTIONS

9.1. Instruction List

Main LCD Driver IC: ILI9320

No.	Registers Name	R/W	RS	D15	D14	D13	D12	D11	D10	D9	D8	D7	D6	D5	D4	D3	D2	D1	D0
IR	Index Register	W	0	-	-	-	-	-	-	-	-	ID7	ID6	ID5	ID4	ID3	ID2	ID1	ID0
SR	Status Read	R	0	L7	L6	L5	L4	L3	L2	L1	L0	0	0	0	0	0	0	0	0
00h	Driver Code Read	R	1	1	0	0	1	0	0	1	0	0	0	1	0	0	0	1	0
00h	Start Oscillation	W	1	-	-	-	-	-	-	-	-	-	-	-	-	-	-	-	OSC
01h	Driver Output Control 1	W	1	0	0	0	0	0	SM	0	SS	0	0	0	0	0	0	0	0
02h	LCD Driving Control	W	1	0	0	0	0	0	1	B/C	EOR	0	0	0	0	0	0	0	0
03h	Entry Mode	W	1	TRI	DFM	0	BGR	0	0	HWM	0	ORG	0	VD1	VD0	AM	0	0	0
04h	Resize Control	W	1	0	0	0	0	0	0	RCV 1	RCV 0	0	0	RCH 1	RCH 0	0	0	RSZ1	RSZ0
07h	Display Control 1	W	1	0	0	PTD E1	PTD E0	0	0	0	BAS EE	0	0	GON	DTE	CL	0	D1	D0
08h	Display Control 2	W	1	0	0	0	0	FP3	FP2	FP1	FP0	0	0	0	0	BP3	BP2	BP1	BP0
09h	Display Control 3	W	1	0	0	0	0	0	PTS2	PTS1	PTS0	0	0	PTG1	PTG0	ISC3	ISC2	ISC1	ISC0
0Ah	Display Control 4	W	1	0	0	0	0	0	0	0	0	0	0	0	0	FMA RKO E	FMI2	FMI1	FMI0
0Ch	RGB Display Interface Control 1	W	1	ENC 2	ENC 1	ENC 0	0	0	0	0	RM	0	0	DM1	DM0	0	0	RIM1	RIM0
0Dh	Frame Maker Position	W	1	0	0	0	0	0	0	0	FMP 8	FMP 7	FMP 6	FMP 5	FMP 4	FMP 3	FMP 2	FMP 1	FMP 0
0Fh	RGB Display Interface Control 2	W	1	0	0	0	0	0	0	0	0	0	0	0	VSPL	HSP L	0	DPL	EPL
10h	Power Control 1	W	1	0	0	0	SAP	BT3	BT2	BT1	BT0	APE	AP2	AP1	AP0	0	DST B	SLP	0
11h	Power Control 2	W	1	0	0	0	0	0	DC12	DC11	DC10	0	DC02	DC01	DC00	0	VC2	VC1	VC0
12h	Power Control 3	W	1	0	0	0	0	0	0	0	VCM R	0	0	0	PON	VRH 3	VRH 2	VRH 1	VRH 0
13h	Power Control 4	W	1	0	0	0	VDV4	VDV3	VDV2	VDV1	VDV0	0	0	0	0	0	0	0	0
20h	Horizontal GRAM Address Set	W	1	0	0	0	0	0	0	0	0	AD7	AD6	AD5	AD4	AD3	AD2	AD1	AD0
21h	Vertical GRAM Address Set	W	1	0	0	0	0	0	0	0	AD16	AD15	AD14	AD13	AD12	AD11	AD10	AD9	AD8
22h	Write Data to GRAM	W	1	RAM write data (WD17-0) / read data (RD17-0) bits are transferred via different data bus lines according to the selected interfaces.															
29h	Power Control 7	W	1	0	0	0	0	0	0	0	0	0	0	0	VCM 4	VCM 3	VCM 2	VCM 1	VCM 0
2Bh	Frame Rate and Color Control	W	1	0	0	0	0	0	0	0	0	EXT_R	0	FR_S EL1	FR_S EL0	0	0	0	0
30h	Gamma Control 1	W	1	0	0	0	0	0	KP1[2]	KP1[1]	KP1[0]	0	0	0	0	0	KP0[2]	KP0[1]	KP0[0]
31h	Gamma Control 2	W	1	0	0	0	0	0	KP3[2]	KP3[1]	KP3[0]	0	0	0	0	0	KP2[2]	KP2[1]	KP2[0]
32h	Gamma Control 3	W	1	0	0	0	0	0	KP5[2]	KP5[1]	KP5[0]	0	0	0	0	0	KP4[2]	KP4[1]	KP4[0]
35h	Gamma Control 4	W	1	0	0	0	0	0	RP1[2]	RP1[1]	RP1[0]	0	0	0	0	0	RP0[2]	RP0[1]	RP0[0]

Preliminary

The contents of this document are confidential and must not be disclosed wholly or in part to any third part without the prior written consent of AMPIRE CO., LTD

36h	Gamma Control 5	W	1	0	0	0	0	VRP1 [4]	VRP1 [3]	VRP1 [2]	VRP1 [1]	VRP1 [0]	0	0	0	VRP0 [4]	VRP0 [3]	VRP0 [2]	VRP0 [1]	VRP0 [0]
37h	Gamma Control 6	W	1	0	0	0	0	0	0	KN1 [2]	KN1 [1]	KN1 [0]	0	0	0	0	0	KN0 [2]	KN0 [1]	KN0 [0]

No.	Registers	R/W	RS	D15	D14	D13	D12	D11	D10	D9	D8	D7	D6	D5	D4	D3	D2	D1	D0
38h	Gamma Control 7	W	1	0	0	0	0	0	KN3 [2]	KN3 [1]	KN3 [0]	0	0	0	0	0	KN2 [2]	KN2 [1]	KN2 [0]
39h	Gamma Control 8	W	1	0	0	0	0	0	KN5 [2]	KN5 [1]	KN5 [0]	0	0	0	0	0	KN4 [2]	KN4 [1]	KN4 [0]
3Ch	Gamma Control 9	W	1	0	0	0	0	0	RN1 [2]	RN1 [1]	RN1 [0]	0	0	0	0	0	RN0 [2]	RN0 [1]	RN0 [0]
3Dh	Gamma Control 10	W	1	0	0	0	VRN 1[4]	VRN 1[3]	VRN 1[2]	VRN 1[1]	VRN 1[0]	0	0	0	VRN 0[4]	VRN 0[3]	VRN 0[2]	VRN 0[1]	VRN 0[0]
50h	Horizontal Address Start Position	W	1	0	0	0	0	0	0	0	0	HSA7	HSA6	HSA5	HSA4	HSA3	HSA2	HSA1	HSA0
51h	Horizontal Address End Position	W	1	0	0	0	0	0	0	0	0	HEA7	HEA6	HEA5	HEA4	HEA3	HEA2	HEA1	HEA0
52h	Vertical Address Start Position	W	1	0	0	0	0	0	0	0	VSA8	VSA7	VSA6	VSA5	VSA4	VSA3	VSA2	VSA1	VSA0
53h	Vertical Address End Position	W	1	0	0	0	0	0	0	0	VEA8	VEA7	VEA6	VEA5	VEA4	VEA3	VEA2	VEA1	VEA0
60h	Driver Output Control 2	W	1	GS	0	NL5	NL4	NL3	NL2	NL1	NL0	0	0	SCN 5	SCN 4	SCN 3	SCN 2	SCN 1	SCN 0
61h	Base Image Display Control	W	1	0	0	0	0	0	0	0	0	0	0	0	0	0	NDL	VLE	REV
6Ah	Vertical Scroll Control	W	1	0	0	0	0	0	0	0	VL8	VL7	VL6	VL5	VL4	VL3	VL2	VL1	VL0
80h	Partial Image 1 Display Position	W	1	0	0	0	0	0	0	0	PTD P08	PTD P07	PTD P06	PTD P05	PTD P04	PTD P03	PTD P02	PTD P01	PTD P00
81h	Partial Image 1 Area (Start Line)	W	1	0	0	0	0	0	0	0	PTSA 08	PTSA 07	PTSA 06	PTSA 05	PTSA 04	PTSA 03	PTSA 02	PTSA 01	PTSA 00
82h	Partial Image 1 Area (End Line)	W	1	0	0	0	0	0	0	0	PTEA 08	PTEA 07	PTEA 06	PTEA 05	PTEA 04	PTEA 03	PTEA 02	PTEA 01	PTEA 00
83h	Partial Image 2 Display Position	W	1	0	0	0	0	0	0	0	PTD P18	PTD P17	PTD P16	PTD P15	PTD P14	PTD P13	PTD P12	PTD P11	PTD P10
84h	Partial Image 2 Area (Start Line)	W	1	0	0	0	0	0	0	0	PTSA 18	PTSA 17	PTSA 16	PTSA 15	PTSA 14	PTSA 13	PTSA 12	PTSA 11	PTSA 10
85h	Partial Image 2 Area (End Line)	W	1	0	0	0	0	0	0	0	PTEA 18	PTEA 17	PTEA 16	PTEA 15	PTEA 14	PTEA 13	PTEA 12	PTEA 11	PTEA 10
90h	Panel Interface Control 1	W	1	0	0	0	0	0	0	DIV11	DIV10 0	0	0	0	0	RTNI 3	RTNI 2	RTNI 1	RTNI 0
92h	Panel Interface Control 2	W	1	0	0	0	0	0	NOW 12	NOW 11	NOW 10	0	0	0	0	0	0	0	0
93h	Panel Interface Control 3	W	1	0	0	0	0	0	0	0	0	0	0	0	0	0	MCPI 2	MCPI 1	MCPI 0
95h	Panel Interface Control 4	W	1	0	0	0	0	0	0	DIVE 1	DIVE 0	0	0	RTN E5	RTN E4	RTN E3	RTN E2	RTN E1	RTN E0
97h	Panel Interface Control 5	W	1	0	0	0	0	NOW E3	NOW E2	NOW E1	NOW E0	0	0	0	0	0	0	0	0
98h	Panel Interface Control 6	W	1	0	0	0	0	0	0	0	0	0	0	0	0	0	MCP E2	MCP E1	

Preliminary

The contents of this document are confidential and must not be disclosed wholly or in part to any third part without the prior written consent of AMPIRE CO., LTD

10. Application

10.1 Display ON / OFF

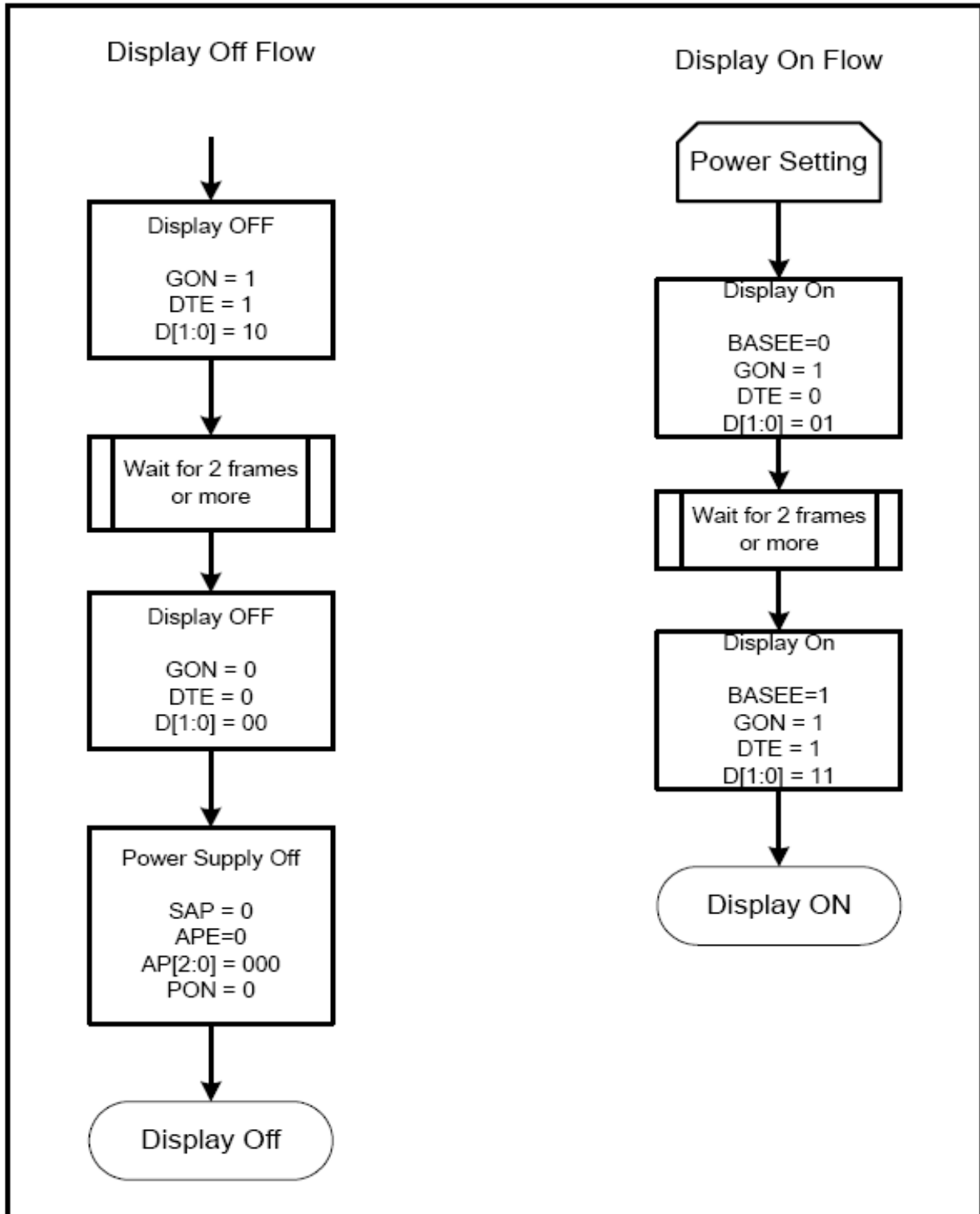

Preliminary

The contents of this document are confidential and must not be disclosed wholly or in part to any third part without the prior written consent of AMPIRE CO., LTD

10.2 Deep Standby and Sleep Mode

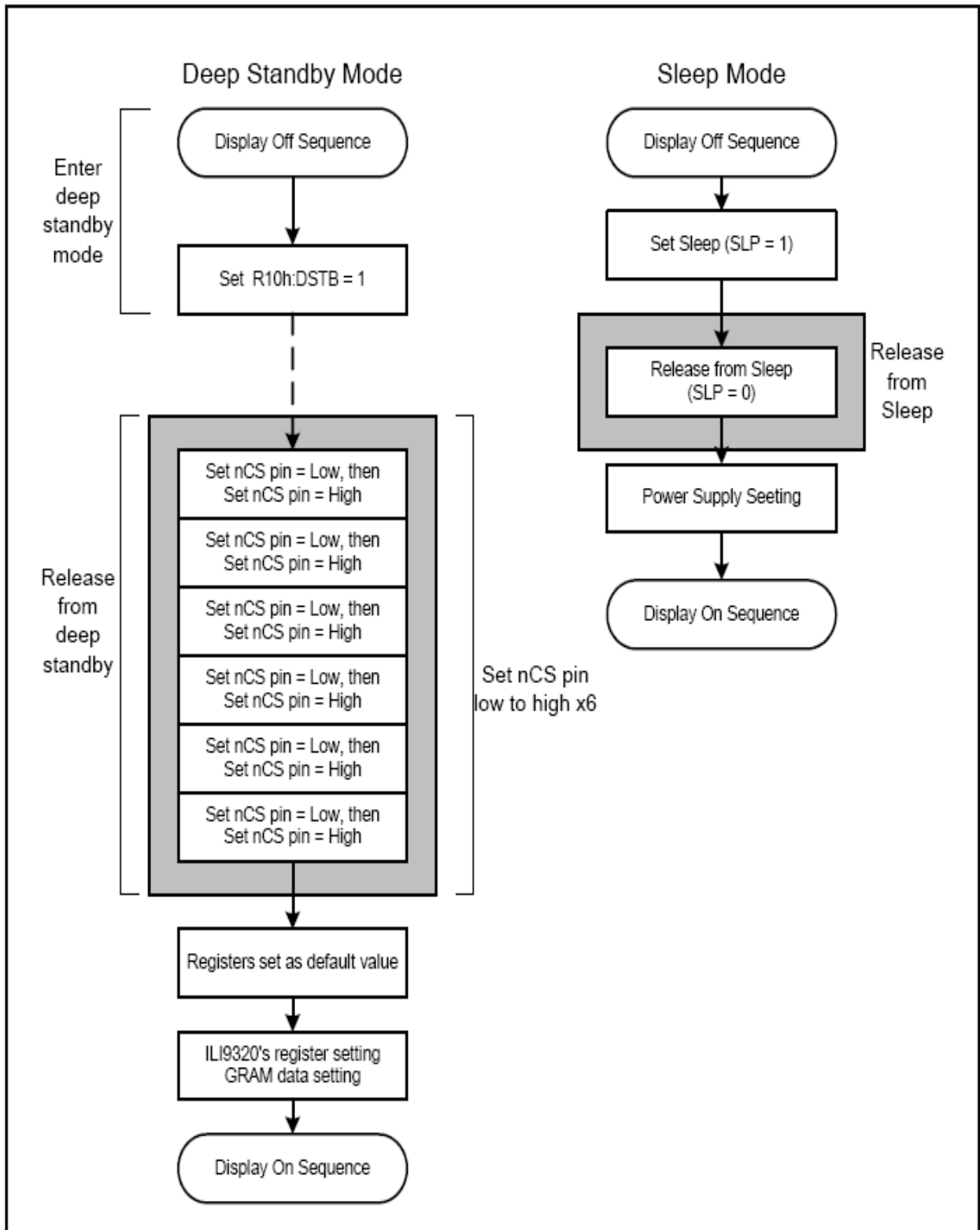

Preliminary

The contents of this document are confidential and must not be disclosed wholly or in part to any third part without the prior written consent of AMPIRE CO., LTD

10.3 Power Supply Configuration

When supplying and cutting off power, follow the sequence below. The setting time for oscillators, step-up circuits and operational amplifiers depends on external resistance and capacitance.

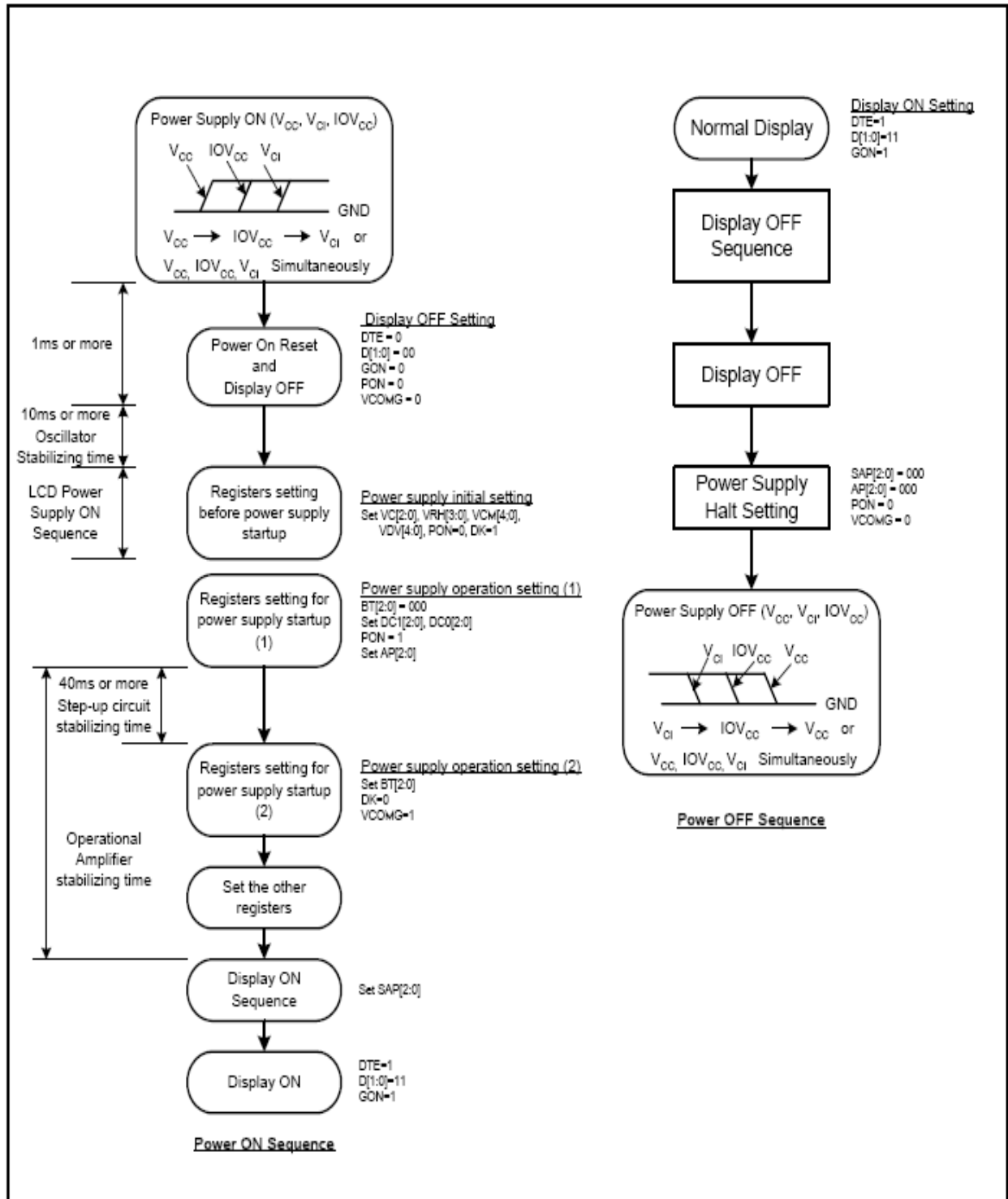

Preliminary

The contents of this document are confidential and must not be disclosed wholly or in part to any third part without the prior written consent of AMPIRE CO., LTD

11. Timing Characteristics

11.1 Clock Characteristics

VCC = 2.40 ~ 3.30V, IOVCC = 1.65 ~ 3.30V

Item	Symbol	Test Condition	Min.	Typ.	Max.	Unit
External Clock Frequency	f _{cp}	VCC = 2.4 ~ 3.3V	450	550	650	KHz
External Clock Duty	f _{duty}	VCC = 2.4 ~ 3.3V	45	50	55	
External Clock Rising Time	Trcp	VCC = 2.4 ~ 3.3V	-	-	0.2	µs
External Clock Falling Time	Tfcp	VCC = 2.4 ~ 3.3V	-	-	0.2	µs
RC oscillation clock	f _{osc}	Rf = 100KΩ, VCC = 2.8V	450	550	650	KHz

11.2 AC Characteristics (i80 – system Interface Timing Characteristics)

Normal Write Mode (IOVCC = 1.65~3.3V, VCC=2.4~3.3V)

Item	Symbol	Unit	Min.	Typ.	Max.	Test Condition
Bus cycle time	Write	t _{CYCW}	ns	100	-	-
	Read	t _{CYCR}	ns	300	-	-
Write low-level pulse width	PW _{LW}	ns	50	-	500	
Write high-level pulse width	PW _{HW}	ns	50	-	-	
Read low-level pulse width	PW _{LR}	ns	150	-	-	
Read high-level pulse width	PW _{HR}	ns	150	-	-	
Write / Read rise / fall time	t _{WRf} /t _{WRr}	ns	-	-	25	
Setup time	Write (RS to nCS, E/nWR)	t _{AS}	ns	10	-	-
	Read (RS to nCS, RW/nRD)			5	-	-
Address hold time	t _{AH}	ns	5	-	-	
Write data set up time	t _{DSW}	ns	10	-	-	
Write data hold time	t _H	ns	15	-	-	
Read data delay time	t _{DDR}	ns	-	-	100	
Read data hold time	t _{DHR}	ns	5	-	-	

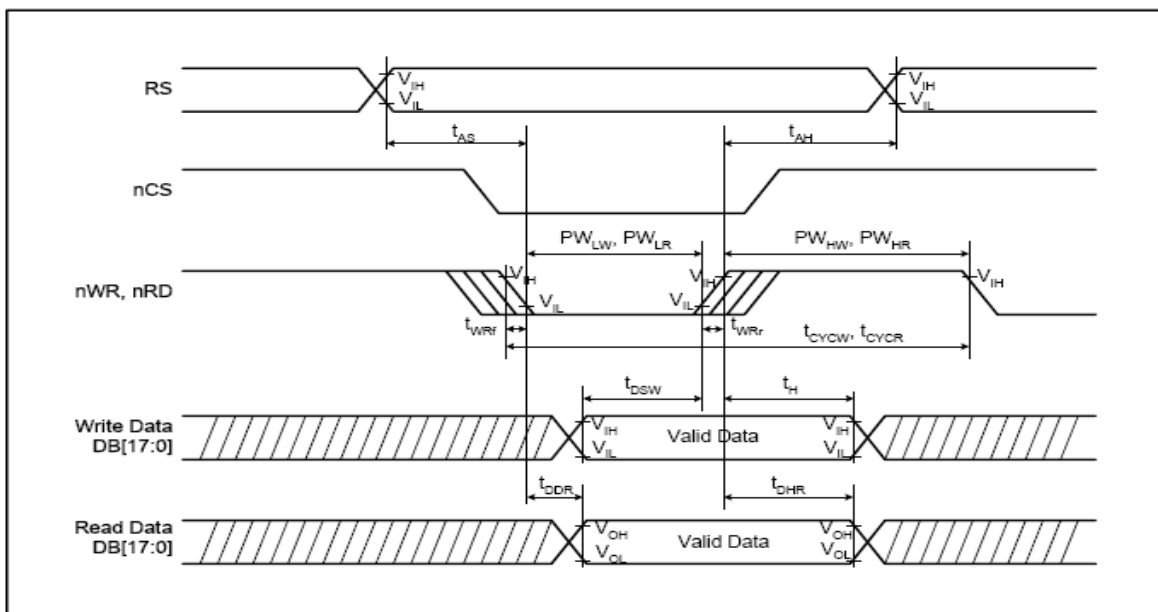

Preliminary

The contents of this document are confidential and must not be disclosed wholly or in part to any third part without the prior written consent of AMPIRE CO., LTD

11.3 AC Characteristics (RGB Interface Timing Characteristics)

18/16-bit Bus RGB Interface Mode (IOVCC = 1.65 ~ 3.3V, VCC=2.4~3.3V)

Item	Symbol	Unit	Min.	Typ.	Max.	Test Condition
VSYNC/HSYNC setup time	t_{SYNCS}	ns	0	-	-	-
ENABLE setup time	t_{ENS}	ns	10	-	-	-
ENABLE hold time	t_{ENH}	ns	10	-	-	-
PD Data setup time	t_{PDS}	ns	10	-	-	-
PD Data hold time	t_{PDH}	ns	40	-	-	-
DOTCLK high-level pulse width	PWDH	ns	40	-	-	-
DOTCLK low-level pulse width	PWDL	ns	40	-	-	-
DOTCLK cycle time	t_{CYCD}	ns	100	-	-	-
DOTCLK, VSYNC, HSYNC, rise/fall time	t_{rghr}, t_{grhr}	ns	-	-	25	-

6-bit Bus RGB Interface Mode (IOVCC = 1.65 ~ 3.3V, VCC=2.4~3.3V)

Item	Symbol	Unit	Min.	Typ.	Max.	Test Condition
VSYNC/HSYNC setup time	t_{SYNCS}	ns	0	-	-	-
ENABLE setup time	t_{ENS}	ns	10	-	-	-
ENABLE hold time	t_{ENH}	ns	10	-	-	-
PD Data setup time	t_{PDS}	ns	10	-	-	-
PD Data hold time	t_{PDH}	ns	30	-	-	-
DOTCLK high-level pulse width	PWDH	ns	30	-	-	-
DOTCLK low-level pulse width	PWDL	ns	30	-	-	-
DOTCLK cycle time	t_{CYCD}	ns	80	-	-	-
DOTCLK, VSYNC, HSYNC, rise/fall time	t_{rghr}, t_{grhr}	ns	-	-	25	-

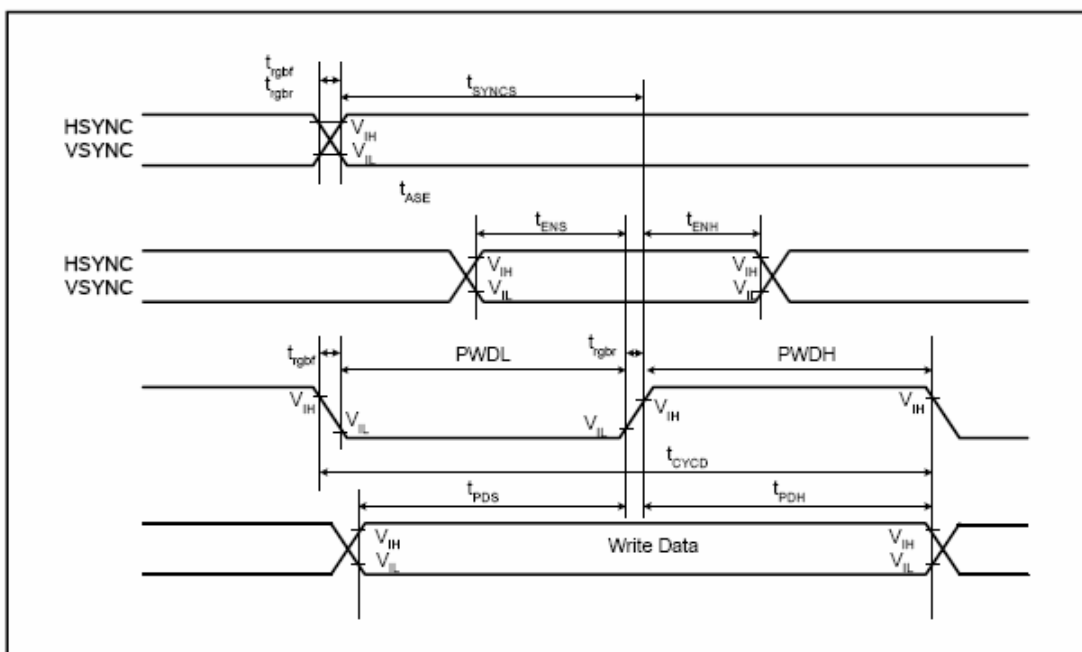

Preliminary

The contents of this document are confidential and must not be disclosed wholly or in part to any third part without the prior written consent of AMPIRE CO., LTD

12 QUALITY AND RELIABILITY

12.1 TEST CONDITIONS

Tests should be conducted under the following conditions :

Ambient temperature : $25 \pm 5^{\circ}\text{C}$

Humidity : $60 \pm 25\% \text{ RH}$.

12.2 SAMPLING PLAN

Sampling method shall be in accordance with MIL-STD-105E , level II, normal single sampling plan .

12.3 ACCEPTABLE QUALITY LEVEL

A major defect is defined as one that could cause failure to or materially reduce the usability of the unit for its intended purpose. A minor defect is one that does not materially reduce the usability of the unit for its intended purpose or is an infringement from established standards and has no significant bearing on its effective use or operation.

12.4 APPEARANCE

An appearance test should be conducted by human sight at approximately 30 cm distance from the LCD module under fluorescent light. The inspection area of LCD panel shall be within the range of following limits.

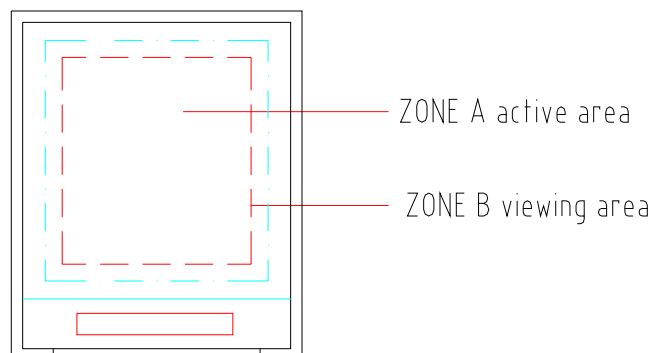

Preliminary

The contents of this document are confidential and must not be disclosed wholly or in part to any third part without the prior written consent of AMPIRE CO., LTD

12.5 INSPECTION QUALITY CRITERIA

No.	Item	Criterion for defects	Defect type															
1	Non display	No non display is allowed	Major															
2	Irregular operation	No irregular operation is allowed	Major															
3	Short	No short are allowed	Major															
4	Open	Any segments or common patterns that don't activate are rejectable.	Major															
5	Black/White spot (I)	<table border="1"> <thead> <tr> <th>Size D (mm)</th> <th>Acceptable number</th> </tr> </thead> <tbody> <tr> <td>$D \leq 0.15$</td> <td>Ignore</td> </tr> <tr> <td>$0.15 < D \leq 0.20$</td> <td>3</td> </tr> <tr> <td>$0.20 < D \leq 0.30$</td> <td>2</td> </tr> <tr> <td>$0.30 < D$</td> <td>0</td> </tr> </tbody> </table>	Size D (mm)	Acceptable number	$D \leq 0.15$	Ignore	$0.15 < D \leq 0.20$	3	$0.20 < D \leq 0.30$	2	$0.30 < D$	0	Minor					
Size D (mm)	Acceptable number																	
$D \leq 0.15$	Ignore																	
$0.15 < D \leq 0.20$	3																	
$0.20 < D \leq 0.30$	2																	
$0.30 < D$	0																	
6	Black/White line (I)	<table border="1"> <thead> <tr> <th>Length(mm)</th> <th>Width (mm)</th> <th>Acceptable number</th> </tr> </thead> <tbody> <tr> <td>$10 < L$</td> <td>$0.03 < W \leq 0.04$</td> <td>5</td> </tr> <tr> <td>$5.0 < L \leq 10$</td> <td>$0.04 < W \leq 0.06$</td> <td>3</td> </tr> <tr> <td>$1.0 < L \leq 5.0$</td> <td>$0.06 < W \leq 0.07$</td> <td>2</td> </tr> <tr> <td>$L \leq 1.0$</td> <td>$0.07 < W \leq 0.09$</td> <td>1</td> </tr> </tbody> </table>	Length(mm)	Width (mm)	Acceptable number	$10 < L$	$0.03 < W \leq 0.04$	5	$5.0 < L \leq 10$	$0.04 < W \leq 0.06$	3	$1.0 < L \leq 5.0$	$0.06 < W \leq 0.07$	2	$L \leq 1.0$	$0.07 < W \leq 0.09$	1	Minor
Length(mm)	Width (mm)	Acceptable number																
$10 < L$	$0.03 < W \leq 0.04$	5																
$5.0 < L \leq 10$	$0.04 < W \leq 0.06$	3																
$1.0 < L \leq 5.0$	$0.06 < W \leq 0.07$	2																
$L \leq 1.0$	$0.07 < W \leq 0.09$	1																
7	Black/White spot (II)	<table border="1"> <thead> <tr> <th>Size D (mm)</th> <th>Acceptable number</th> </tr> </thead> <tbody> <tr> <td>$D \leq 0.30$</td> <td>Ignore</td> </tr> <tr> <td>$0.30 < D \leq 0.50$</td> <td>5</td> </tr> <tr> <td>$0.50 < D \leq 1.20$</td> <td>3</td> </tr> <tr> <td>$1.20 < D$</td> <td>0</td> </tr> </tbody> </table>	Size D (mm)	Acceptable number	$D \leq 0.30$	Ignore	$0.30 < D \leq 0.50$	5	$0.50 < D \leq 1.20$	3	$1.20 < D$	0	Minor					
Size D (mm)	Acceptable number																	
$D \leq 0.30$	Ignore																	
$0.30 < D \leq 0.50$	5																	
$0.50 < D \leq 1.20$	3																	
$1.20 < D$	0																	
8	Black/White line (II)	<table border="1"> <thead> <tr> <th>Length (mm)</th> <th>Width (mm)</th> <th>Acceptable number</th> </tr> </thead> <tbody> <tr> <td>$20 < L$</td> <td>$0.05 < W \leq 0.07$</td> <td>5</td> </tr> <tr> <td>$10 < L \leq 20$</td> <td>$0.07 < W \leq 0.09$</td> <td>3</td> </tr> <tr> <td>$5.0 < L \leq 10$</td> <td>$0.09 < W \leq 0.10$</td> <td>2</td> </tr> <tr> <td>$L \leq 5.0$</td> <td>$0.10 < W \leq 0.15$</td> <td>1</td> </tr> </tbody> </table>	Length (mm)	Width (mm)	Acceptable number	$20 < L$	$0.05 < W \leq 0.07$	5	$10 < L \leq 20$	$0.07 < W \leq 0.09$	3	$5.0 < L \leq 10$	$0.09 < W \leq 0.10$	2	$L \leq 5.0$	$0.10 < W \leq 0.15$	1	Minor
Length (mm)	Width (mm)	Acceptable number																
$20 < L$	$0.05 < W \leq 0.07$	5																
$10 < L \leq 20$	$0.07 < W \leq 0.09$	3																
$5.0 < L \leq 10$	$0.09 < W \leq 0.10$	2																
$L \leq 5.0$	$0.10 < W \leq 0.15$	1																
9	Back Light	1. No Lighting is rejectable 2. Flickering and abnormal lighting are rejectable	Major															

Preliminary

The contents of this document are confidential and must not be disclosed wholly or in part to any third part without the prior written consent of AMPIRE CO., LTD

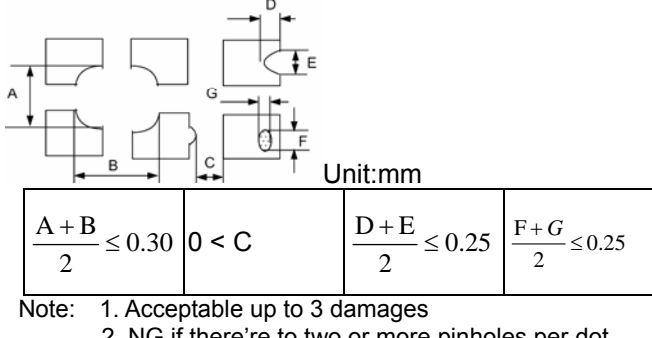
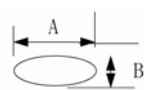
10	Display pattern	 <p style="text-align: center;">Unit:mm</p> <table border="1" style="margin-left: auto; margin-right: auto;"> <tr> <td>$\frac{A+B}{2} \leq 0.30$</td> <td>$0 < C$</td> <td>$\frac{D+E}{2} \leq 0.25$</td> <td>$\frac{F+G}{2} \leq 0.25$</td> </tr> </table> <p>Note: 1. Acceptable up to 3 damages 2. NG if there're two or more pinholes per dot</p>	$\frac{A+B}{2} \leq 0.30$	$0 < C$	$\frac{D+E}{2} \leq 0.25$	$\frac{F+G}{2} \leq 0.25$	Minor																	
$\frac{A+B}{2} \leq 0.30$	$0 < C$	$\frac{D+E}{2} \leq 0.25$	$\frac{F+G}{2} \leq 0.25$																					
11	Blemish & Foreign matters Size: $D = \frac{A+B}{2}$	<table border="1" style="width: 100%;"> <thead> <tr> <th>Size D (mm)</th> <th>Acceptable number</th> </tr> </thead> <tbody> <tr> <td>$D \leq 0.15$</td> <td>Ignore</td> </tr> <tr> <td>$0.15 < D \leq 0.20$</td> <td>3</td> </tr> <tr> <td>$0.20 < D \leq 0.30$</td> <td>2</td> </tr> <tr> <td>$0.30 < D$</td> <td>0</td> </tr> </tbody> </table>	Size D (mm)	Acceptable number	$D \leq 0.15$	Ignore	$0.15 < D \leq 0.20$	3	$0.20 < D \leq 0.30$	2	$0.30 < D$	0	Minor											
Size D (mm)	Acceptable number																							
$D \leq 0.15$	Ignore																							
$0.15 < D \leq 0.20$	3																							
$0.20 < D \leq 0.30$	2																							
$0.30 < D$	0																							
12	Scratch on Polarizer 	<table border="1" style="width: 100%;"> <thead> <tr> <th>Width (mm)</th> <th>Length (mm)</th> <th>Acceptable number</th> </tr> </thead> <tbody> <tr> <td>$W \leq 0.03$</td> <td>Ignore</td> <td>Ignore</td> </tr> <tr> <td>$0.03 < W \leq 0.05$</td> <td>$L \leq 2.0$</td> <td>Ignore</td> </tr> <tr> <td></td> <td>$L > 2.0$</td> <td>1</td> </tr> <tr> <td>$0.05 < W \leq 0.08$</td> <td>$L > 1.0$</td> <td>1</td> </tr> <tr> <td></td> <td>$L \leq 1.0$</td> <td>Ignore</td> </tr> <tr> <td>$0.08 < W$</td> <td>Note (1)</td> <td>Note(1)</td> </tr> </tbody> </table> <p>Note(1) Regard as a blemish</p>	Width (mm)	Length (mm)	Acceptable number	$W \leq 0.03$	Ignore	Ignore	$0.03 < W \leq 0.05$	$L \leq 2.0$	Ignore		$L > 2.0$	1	$0.05 < W \leq 0.08$	$L > 1.0$	1		$L \leq 1.0$	Ignore	$0.08 < W$	Note (1)	Note(1)	Minor
Width (mm)	Length (mm)	Acceptable number																						
$W \leq 0.03$	Ignore	Ignore																						
$0.03 < W \leq 0.05$	$L \leq 2.0$	Ignore																						
	$L > 2.0$	1																						
$0.05 < W \leq 0.08$	$L > 1.0$	1																						
	$L \leq 1.0$	Ignore																						
$0.08 < W$	Note (1)	Note(1)																						
13	Bubble in polarizer	<table border="1" style="width: 100%;"> <thead> <tr> <th>Size D (mm)</th> <th>Acceptable number</th> </tr> </thead> <tbody> <tr> <td>$D \leq 0.20$</td> <td>Ignore</td> </tr> <tr> <td>$0.20 < D \leq 0.50$</td> <td>3</td> </tr> <tr> <td>$0.50 < D \leq 0.80$</td> <td>2</td> </tr> <tr> <td>$0.80 < D$</td> <td>0</td> </tr> </tbody> </table>	Size D (mm)	Acceptable number	$D \leq 0.20$	Ignore	$0.20 < D \leq 0.50$	3	$0.50 < D \leq 0.80$	2	$0.80 < D$	0	Minor											
Size D (mm)	Acceptable number																							
$D \leq 0.20$	Ignore																							
$0.20 < D \leq 0.50$	3																							
$0.50 < D \leq 0.80$	2																							
$0.80 < D$	0																							
14	Stains on LCD panel surface	Stains that cannot be removed even when wiped lightly with a soft cloth or similar cleaning too are rejectable.	Minor																					
15	Rust in Bezel	Rust which is visible in the bezel is rejectable.	Minor																					
16	Defect of land surface contact (poor soldering)	Evident crevices which is visible are rejectable.	Minor																					
17	Parts mounting	<ol style="list-style-type: none"> 1. Failure to mount parts 2. Parts not in the specifications are mounted 3. Polarity, for example, is reversed 	Major Major Major																					

Preliminary

The contents of this document are confidential and must not be disclosed wholly or in part to any third part without the prior written consent of AMPIRE CO., LTD

18	Parts alignment	<ol style="list-style-type: none">1. LSI, IC lead width is more than 50% beyond pad outline.2. Chip component is off center and more than 50% of the leads is off the pad outline.	Minor Minor
19	Conductive foreign matter (Solder ball, Solder chips)	<ol style="list-style-type: none">1. $0.45 < \varphi$, $N \geq 1$2. $0.30 < \varphi \leq 0.45$, $N \geq 1$ φ :Average diameter of solder ball (unit: mm)3. $0.50 < L$, $N \geq 1$ L: Average length of solder chip (unit: mm)	Major Minor Minor
20	Faulty PCB correction	<ol style="list-style-type: none">1. Due to PCB copper foil pattern burnout, the pattern is connected, using a jumper wire for repair; 2 or more places are corrected per PCB.2. Short circuited part is cut, and no resist coating has been performed.	Minor Minor

Preliminary

The contents of this document are confidential and must not be disclosed wholly or in part to any third part without the prior written consent of AMPIRE CO., LTD

12.6 RELIABILITY

Test Item	Test Conditions	Note
High Temperature Operation	70±3°C , t=96 hrs	
Low Temperature Operation	-20±3°C , t=96 hrs	
High Temperature Storage	80±3°C , t=96 hrs	1,2
Low Temperature Storage	-30±3°C , t=96 hrs	1,2
Humidity Test	40°C , Humidity 90%, 96 hrs	1,2
Thermal Shock Test	-30°C ~ 25°C ~ 70°C 30 min. 5 min. 30 min. (1 cycle) Total 5 cycle	1,2
Vibration Test (Packing)	Sweep frequency : 10~55~10 Hz/1min Amplitude : 0.75mm Test direction : X.Y.Z/3 axis Duration : 30min/each axis	2
Static Electricity	150pF 330 ohm ±8kV, 10times air discharge	

Note 1 : Condensation of water is not permitted on the module.

Note 2 : The module should be inspected after 1 hour storage in normal conditions

(15-35°C , 45-65%RH).

Definitions of life end point :

- Current drain should be smaller than the specific value.
- Function of the module should be maintained.
- Appearance and display quality should not have degraded noticeably.
- Contrast ratio should be greater than 50% of the initial value.

Preliminary

The contents of this document are confidential and must not be disclosed wholly or in part to any third part without the prior written consent of AMPIRE CO., LTD

13 USE PRECAUTIONS

13.1 Handling precautions

- 1) The polarizing plate may break easily so be careful when handling it. Do not touch, press or rub it with a hard-material tool like tweezers.
- 2) Do not touch the polarizing plate surface with bare hands so as not to make it dirty. If the surface or other related part of the polarizing plate is dirty, soak a soft cotton cloth or chamois leather in benzine and wipe off with it. Do not use chemical liquids such as acetone, toluene and isopropyl alcohol. Failure to do so may bring chemical reaction phenomena and deteriorations.
- 3) Remove any spit or water immediately. If it is left for hours, the suffered part may deform or decolorize.
- 4) If the LCD element breaks and any LC stuff leaks, do not suck or lick it. Also if LC stuff is stuck on your skin or clothing, wash thoroughly with soap and water immediately.

13.2 Installing precautions

- 1) To prevent breaking by static electricity from the human body and clothing, earth the human body properly using the high resistance and discharge static electricity during the operation. In this case, however, the resistance value should be approx. $1M\Omega$ and the resistance should be placed near the human body rather than the ground surface. When the indoor space is dry, static electricity may occur easily so be careful. We recommend the indoor space should be kept with humidity of 60% or more. When a soldering iron or other similar tool is used for assembly, be sure to earth it.
- 2) When installing the module and ICs, do not bend or twist them. Failure to do so may crack LC element and cause circuit failure.
- 3) To protect LC element, especially polarizing plate, use a transparent protective plate (e.g., acrylic plate, glass etc) for the product case.
- 4) Do not use an adhesive like a both-side adhesive tape to make LCD surface (polarizing plate) and product case stick together. Failure to do so may cause the polarizing plate to peel off.

Preliminary

The contents of this document are confidential and must not be disclosed wholly or in part to any third part without the prior written consent of AMPIRE CO., LTD

13.3 Storage precautions

- 1) Avoid a high temperature and humidity area. Keep the temperature between 0°C and 35°C and also the humidity under 60%.
- 2) Choose the dark spaces where the product is not exposed to direct sunlight or fluorescent light.
- 3) Store the products as they are put in the boxes provided from us or in the same conditions as we recommend.

13.4 Operating precautions

- 1) Do not boost the applied drive voltage abnormally. Failure to do so may break ICs. When applying power voltage, check the electrical features beforehand and be careful. Always turn off the power to the LC module controller before removing or inserting the LC module input connector. If the input connector is removed or inserted while the power is turned on, the LC module internal circuit may break.
- 2) The display response may be late if the operating temperature is under the normal standard, and the display may be out of order if it is above the normal standard. But this is not a failure; this will be restored if it is within the normal standard.
- 3) The LCD contrast varies depending on the visual angle, ambient temperature, power voltage etc. Obtain the optimum contrast by adjusting the LC drive voltage.
- 4) When carrying out the test, do not take the module out of the low-temperature space suddenly. Failure to do so will cause the module condensing, leading to malfunctions.
- 5) Make certain that each signal noise level is within the standard (L level: 0.2V_{dd} or less and H level: 0.8V_{dd} or more) even if the module has functioned properly. If it is beyond the standard, the module may often malfunction. In addition, always connect the module when making noise level measurements.
- 6) The CMOS ICs are incorporated in the module and the pull-up and pull-down function is not adopted for the input so avoid putting the input signal open while the power is ON.
- 7) The characteristic of the semiconductor element changes when it is exposed to

Preliminary

The contents of this document are confidential and must not be disclosed wholly or in part to any third part without the prior written consent of AMPIRE CO., LTD

light emissions, therefore ICs on the LCD may malfunction if they receive light emissions. To prevent these malfunctions, design and assemble ICs so that they are shielded from light emissions.

- 8) Crosstalk occurs because of characteristics of the LCD. In general, crosstalk occurs when the regularized display is maintained. Also, crosstalk is affected by the LC drive voltage. Design the contents of the display, considering crosstalk.

13.5 Other

- 1) Do not disassemble or take the LC module into pieces. The LC modules once disassembled or taken into pieces are not the guarantee articles.
- 2) The residual image may exist if the same display pattern is shown for hours. This residual image, however, disappears when another display pattern is shown or the drive is interrupted and left for a while. But this is not a problem on reliability.

