

An Approach to Biped Robot Control According to Surface Condition of Ground

T.Ono

T.Murakami

K.Ohnishi

Dept. of Electrical Engineering
Keio University

3-14-1, Hiyoshi, Kohoku, Yokohama 223-8522 Japan

Abstract

This paper describes an approach of a biped robot control to realize a stable walking motion under a floor condition with an unknown slope. A slope angle is detected by information of touch sensors which are mounted on the soles and encoders fixed on the joints. The tip trajectory of free swing leg and the position of the center of gravity are modified by the detected slope angle. In this paper, the biped robot is treated as a redundant manipulator and its configuration is achieved by the null space vector. This paper introduces the novel algorithm to determine the slope angle by utilizing the null space motion. Furthermore the disturbance observer is employed as a disturbance compensator to make sure the total motion including the null space motion. The numerical and experimental results are also shown to confirm the validity of the proposed method.

1 Introduction

Recently, the sophisticated robots for various purposes are required, which widely stimulates the development of flexible robot system. The almost all practicable robots work in the limited environment such as the mass production line of the factories. Such robots are not suitable for the environmental coexistence with human beings since their mechanical structure is completely different from human beings. To improve the above issue, several approaches have been proposed to realize the humanoid robot. The biped robots is one of them.

In general approaches of the biped robots, many researchers take up walking configuration and stability to realize the smooth walking motion. Then the almost all studies assume that biped robots walk on

the ideal flat floor and ignore the disturbances on the floor. In the practical application, however, the floor is not always flat and it is difficult to achieve the stable walking motion without considering the floor condition.

This paper considers a floor condition with an unknown slope and proposes a strategy to obtain a stable walking motion even if the floor condition, that is, the slope angle changes. In the proposed approach, the slope angle is estimated by using on/off information of touch sensors mounted on the soles and each joint angle. Then the tip trajectory of the free swing leg and the position of the center of gravity are controlled according to the estimated slope angle to increase the walking stability. In this case, the exact information of the slope angle is not needed. This is one of the remarkable points of the proposed approach.

This paper is composed of eight parts. Part two shows dynamic model of our six degrees-of-freedom biped robot. In parts three and four, the trajectory planning of free swing leg and the final acceleration reference to the position controller are shown. Then the performance indexes to determine the null space motion is also discussed. Part five shows the estimation method of the unknown slope angle. Several numerical and experimental results are implemented in parts six and seven respectively. The conclusions are summarized in part eight.

2 A Model of Biped Robot in Sagittal Plane

Figure 2 shows the biped robot which has six degrees-of-freedom motion in the sagittal plane. Touch sensors are mounted on the toe and the heel of soles which are detectable their contacts on the floor. In this paper, the total system is regarded as a redun-

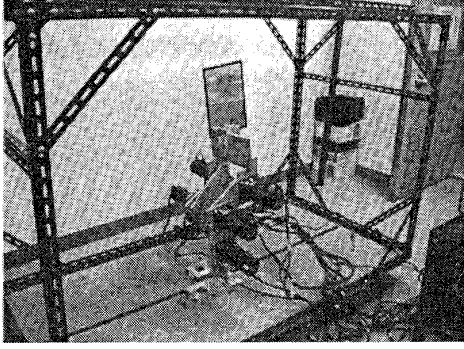

Figure 1: Biped Robot

dant manipulator and its configuration is determined by the null space motion. it is detectable the contact of the toe or the heel on the road.

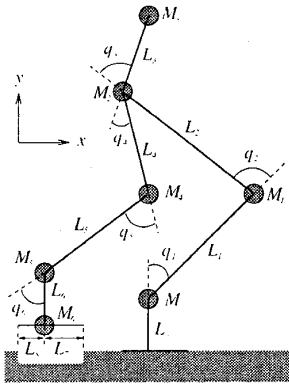

Figure 2: A Model of the Biped Robot

To simplify the analysis of the biped robot system, the link-mass model is introduced as shown in Figure 2, where tip mass of each link M_i shows the mass of i -th link, and its length is L_i .

3 Trajectory Planning

Eq. (1) shows the reference vector of tip position of free swing leg, which is determined by Eq. (2) and (3)

$$\mathbf{x}^{ref} = \begin{pmatrix} x^{ref} \\ y^{ref} \end{pmatrix} \quad (1)$$

$$x^{ref} = \begin{cases} \frac{D}{T}t - \frac{D}{2}, & \text{for } t \leq T \\ \frac{D}{2}, & \text{for } t > T \end{cases} \quad (2)$$

$$y^{ref} = -H\left(\frac{D}{2}\right)^2 \left(x^{ref} - \frac{D}{2}\right)\left(x^{ref} + \frac{D}{2}\right) \quad (3)$$

- t : time
- D : one step walking distance
- H : height of the highest point of tip of free swing leg
- T : walking period

Figure 3 illustrates the tip position reference of the free swing leg in the sagittal plane.

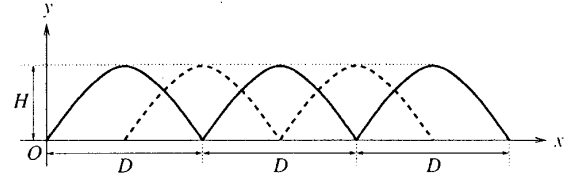

Figure 3: Tip Position Reference of Free Swing Leg

From Eq. (2) and (3), the velocity reference of tip of free swing leg $\dot{\mathbf{x}}$ is derived by differentiation of position and position reference.

The final acceleration reference synthesized by PD controller is given as follows,

$$\ddot{\mathbf{x}}^{cmd} = K_p (\mathbf{x}^{ref} - \mathbf{x}^{res}) + K_v (\dot{\mathbf{x}}^{ref} - \dot{\mathbf{x}}^{res}) \quad (4)$$

where \mathbf{x}^{res} , $\dot{\mathbf{x}}^{res}$, K_p and K_v represent response of position and velocity, and feedback gains of position and velocity. The above motion reference is utilized for the tip position control of free swing leg.

4 Configuration Control by Null Space Vector

As mentioned before, the biped robot is regarded as a redundant manipulator in our approach. Then the joint angular acceleration command $\ddot{\mathbf{q}}^{cmd}$ is given by Eq. (5) which includes the null space reference to determine the walking configuration.

$$\ddot{\mathbf{q}}^{cmd} = \mathbf{J}_{aco}^+ \ddot{\mathbf{x}}^{ref} + (\mathbf{I} - \mathbf{J}_{aco}^+ \mathbf{J}_{aco}) \psi \quad (5)$$

- $\ddot{q}^{ref} \in \mathfrak{R}^{6 \times 1}$: angular acceleration command vector
- $J_{aco} \in \mathfrak{R}^{2 \times 6}$: Jacobian
- $J_{aco}^+ \in \mathfrak{R}^{6 \times 2}$: pseudo inverse matrix of Jacobian
- $I \in \mathfrak{R}^{6 \times 6}$: identity matrix
- $\psi \in \mathfrak{R}^{6 \times 1}$: arbitrary vector

The second term of the right side of Eq. (5) is called null space vector which has an effect to control configuration independently of the tip position of the redundant manipulator.

There exist various solution of the configurations according to vector ψ determined by arbitrary performance functions.

This paper introduces the following five performance functions to increase the stability and flexibility of the walking motion.

- dumping feedback
 - \Rightarrow This term contributes the increasement of the motion stability.

$$\phi_{dump\ i} = -\dot{q}_i \quad (6)$$

- minimizing the change of COG(the center of gravity) in y -direction
 - \Rightarrow This has an effect to minimize the change between the response s_y^{res} and the desired position s_y^d of COG in y -direction.

$$\phi_{cog\ y} = (s_y^d - s_y^{res})^2 \quad (7)$$

- minimizing the change of COG in x -direction
 - \Rightarrow This has an effect to minimize the change between the response s_x^{res} and the desired position s_x^d of COG in x -direction. Here, the desired position s_x^d is the middle point between the tip positions of the support leg and the free swing leg.

$$\phi_{cog\ x} = (s_x^d - s_x^{res})^2 \quad (8)$$

- minimizing the change of absolute angle of the third link

\Rightarrow This has an effect to minimize the change between the response θ_3^{res} and the desired absolute angle θ_3^d of the third link. Here, the desired absolute angle θ_3^d is the vertical configuration. Eq. (9) which guarantees the stable walking even if there exists the floor slope,

$$\phi_{3rd} = (\theta_3^d - \theta_3^{res})^2 \quad (9)$$

where

$$\theta_i^{res} = q_1^{res} + \dots + q_i^{res} \quad (10)$$

- minimizing the change of absolute angle of the sixth link

\Rightarrow This has an effect to minimize the change between the response θ_6^{res} and the desired absolute angle θ_6^d of the sixth link. Here, the desired absolute angle θ_6^d is the vertical configuration according to the floor slope to keep the stable contact of the sole on the floor.

$$\phi_{6th} = (\theta_6^d - \theta_6^{res})^2 \quad (11)$$

By introducing the above performance functions, the final reference of the null space vector is given as follows,

$$\psi_i = k_1 \phi_{dump\ i} + k_2 \frac{\partial \phi_{cog\ y}}{\partial q_i} + k_3 \frac{\partial \phi_{cog\ x}}{\partial q_i} + k_4 \frac{\partial \phi_{3rd}}{\partial q_i} + k_5 \frac{\partial \phi_{6th}}{\partial q_i} \quad (12)$$

where k_i represent the arbitrary gains of each performance function.

5 Recognition of Unknown Slope Condition

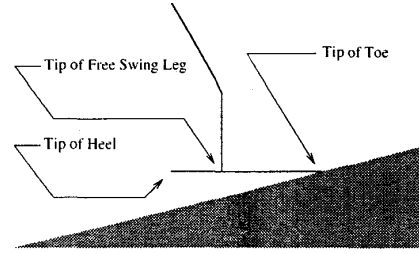

Figure 4: Contact on an Upslope

This part shows the recognition algorithm of the floor slope in the walking motion. In the general walking motion without considering the floor slope, first, tip of the toe contacts the floor when the sole of free swing leg keeps horizontally as shown in Figure 4. Then the position reference Eq. (2) and (3) make it easy to become unstable because the sole may not be able to keep the horizontal configuration on the floor and the robot falls down. To avoid the above unacceptable motion, it is necessary to modify the motion reference including the null space motion. The next section shows a simple algorithm to estimate the floor slope and its application to the modification of the position reference.

5.1 A Modification of Position Reference

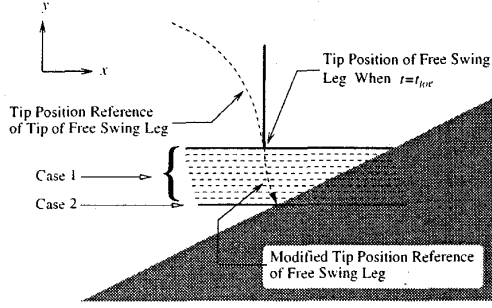

Figure 5: Modified Position Reference

As described before, it is easy to recognize the instantaneous contact between the tip of toe and the floor by the touch sensor mounted on the toe of sole. In case the contact of the toe is detected ($t = t_{toe}$), the position reference of tip of free swing leg is modified so that the sole contacts the floor horizontally. This modification is implemented until the contact between the tip of heel and the floor is detected ($t = t_{heel}$). The modification algorithm of the position reference is illustrated in Figure 5. From this figure, the shape of the modified trajectory is the arched line and the position reference x^{ref} is given as following,

- when $t_{toe} \leq t \leq t_{heel}$ (Case 1)

$$x^{ref} = x_{t_{toe}}^{res} + L_7 \sin\left\{\theta_6^{res}_{t_{toe}} + \frac{\pi}{2} + \omega^{ref}(t - t_{toe})\right\} \quad (13)$$

$$y^{ref} = y_{t_{toe}}^{res} + L_7 \cos\left\{\theta_6^{res}_{t_{toe}} + \frac{\pi}{2} + \omega^{ref}(t - t_{toe})\right\} \quad (14)$$

- when $t \geq t_{heel}$ (Case 2)

$$x^{ref} = x_{t_{toe}}^{res} + L_7 \sin\left\{\theta_6^{res}_{t_{toe}} + \frac{\pi}{2} + \omega^{ref}(t_{heel} - t_{toe})\right\} \quad (15)$$

$$y^{ref} = y_{t_{toe}}^{res} + L_7 \cos\left\{\theta_6^{res}_{t_{toe}} + \frac{\pi}{2} + \omega^{ref}(t_{heel} - t_{toe})\right\} \quad (16)$$

- ω^{ref} : angular velocity of the arched position reference
- $x_{t_{toe}}^{res}$: the tip position of free swing leg when $t = t_{toe}$
- $\theta_6^{res}_{t_{toe}}$: the absolute angle response of sixth link when $t = t_{toe}$

5.2 A Modification of Performance Function

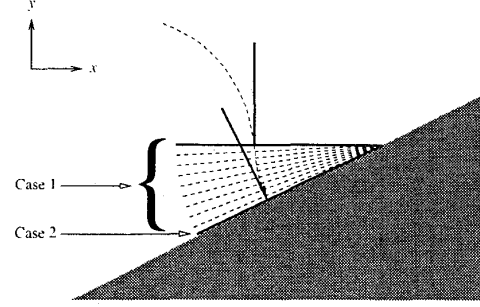

Figure 6: Modified Performance Function

As shown in the former section, the tip position reference of the free swing leg is modified to realize the stable contact of sole according to the detected contact information of the toe and heel by the touch sensor. In this case, the convergence speed, that is, the response speed from Case 1 to Case 2 configuration shown in Figure 6 depends on the arbitrary angular velocity of the arched position reference ω^{ref} . Furthermore the configuration control with respect to the absolute angle θ_6^{res} is also important to achieve the smooth contact of the heel to the floor so that the toe does not de-touch the floor. From this point of view, the desired absolute angle θ_6^d of Eq. (11) is given as follows.

- when $t_{toe} \leq t \leq t_{heel}$ (Case 1)

$$\theta_6^d = -\frac{\pi}{2} + \omega^{ref}(t - t_{toe}) \quad (17)$$

- when $t \geq t_{heel}$ (Case 2)

$$\theta_6^d = -\frac{\pi}{2} + \omega^{ref}(t_{heel} - t_{toe}) \quad (18)$$

5.3 Estimation of the Slope Angle

In the proposed approach, it is easy to estimate the unknown slope angle by using the response θ_6^{res} . In this case, $\theta_6^{res}_{t_{heel}}$ corresponds to the slope angle θ_{slope}^{res} when the contact between the tip of heel and the floor is detected by the touch sensor mounted on the heel of sole ($t = t_{heel}$).

$$\theta_{slope}^{res} = \theta_6^{res}_{t_{heel}} \quad (19)$$

The tip position reference of free swing leg in the next step is also modified by the estimated slope angle θ_{slope}^{res} , which is given by Eq. (20). Here x^{iref} and y^{iref} are the position reference without considering the slope.

$$\begin{pmatrix} x^{ref} \\ y^{ref} \end{pmatrix} = \begin{pmatrix} \cos \theta_{slope}^{res} & \sin \theta_{slope}^{res} \\ -\sin \theta_{slope}^{res} & \cos \theta_{slope}^{res} \end{pmatrix} \begin{pmatrix} x^{iref} \\ y^{iref} \end{pmatrix} \quad (20)$$

The desired position of COG in y -direction s_y^d is also modified according to the estimated slope angle θ_{slope}^{res} .

As shown in the former discussion, the upslope is assumed to construct the control algorithm. In case the walking motion on an unknown downslope, the similar approach is applicable to the heel motion. Hence the above concept of the upslope can be extended to the motion of the unknown downslope.

6 Numerical Result

Table 1 shows the length of i -th link L_i and the mass of i -th link M_i in Figure 2.

Table 1: Length and mass of each link

L_i	length [m]	M_i	mass [kg]
L_0	0.080	M_0	3.60
L_1	0.160	M_1	3.60
L_2	0.160	M_2	7.20
L_3	0.216	M_3	0.50
L_4	0.160	M_4	3.60
L_5	0.160	M_5	3.60
L_6	0.080	M_6	0.60
L_7	0.160		
L_8	0.080		

The parameters which decide the position reference in Eq. (2) and (3) is given as following.

$$\begin{aligned} D &= 0.20 \quad [\text{m}] \\ H &= 0.05 \quad [\text{m}] \\ T &= 3.00 \quad [\text{sec}] \end{aligned}$$

In Figure 7, the simulation and the experiment are implemented under the following conditions.

Conditions :

1. The angle of the start point is $\pm 0[\text{deg}]$ and it is known, but the angle and the start point of the next slope are unknown.

2. The slope angles : $\pm 0[\text{deg}](\text{known}) \Rightarrow +7.18[\text{deg}](\text{unknown})$
3. The start point of the slope : $0.22[\text{m}](\text{unknown})$

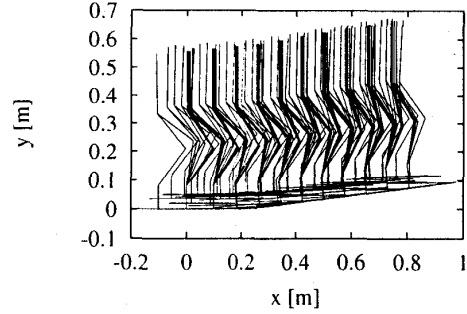

Figure 7: Stick Diagram of Walking Motion

As shown in the numerical experiments, the walking motion is successfully achieved even if the unknown slope exists.

7 Experimental Result

To confirm the validity of the proposed approach, several experiments are also implemented. The experimental results are shown in Figure 8 ~ Figure 11. The biped robot realizes the stable walking without effect of the floor slope. These results show the feasibility of the proposed approach.

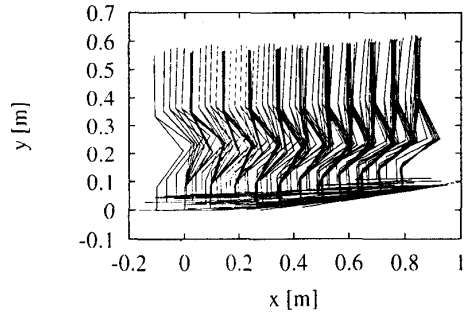

Figure 8: Stick Diagram of Walking Motion

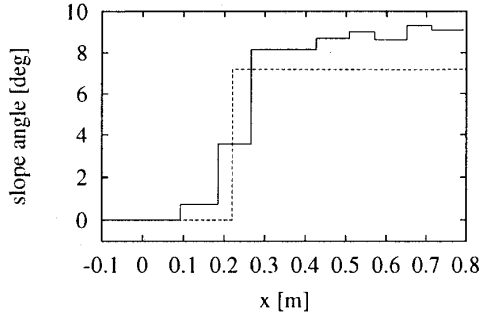

Figure 9: Estimation of the Slope Angle

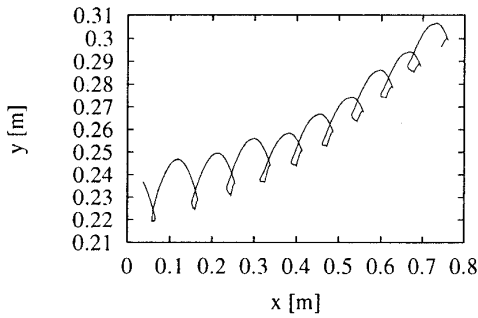

Figure 10: Center of Gravity

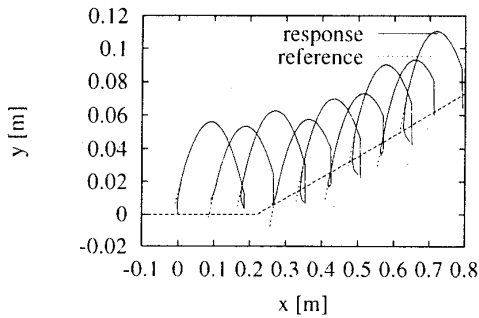

Figure 11: Tip Position of the Free Swing Leg

8 Conclusions

This paper proposes the strategy of the biped robot control to realize a stable walking motion under a floor condition with an unknown slope. In the proposed approach, the biped robot is regarded as redundant manipulator and the slope angle is estimated by the touch sensors and the null space motion. In this case, the high cost sensor is not needed to know slope angle. This is one of the remarkable points of the proposed approach. The feasibility of proposed approach is confirmed by several numerical and experimental results.

References

- [1] Y. F. Zheng and J. Shen, "Gait Synthesis for the SD-2 Biped Robot to Climb Sloping Surface" *IEEE Transactions on Robotics and Automation*, Vol. 6, No. 1, pp. 86-96, Feb., 1990.
- [2] A. W. Salatian and Y. F. Zheng, "Gait Synthesis for the SD-2 Biped Robot to Climb Sloping Surface Using Neural Network," *Proceeding of the IEEE International Conference on Robotics and Automation*, Vol. 3, pp. 2601-2606, 1992.
- [3] G. Z. Tan, "Study on Mechanics Laws for Anthropomorphic Biped Robot to Walk Dynamically on Sloping Surface," *Proceeding of the IEEE International Conference on Robotics and Automation*, Vol. 1, pp. 252-257, 1996.
- [4] N. Sonoda, T. Murakami and K. Ohnishi, "An Approach to Stable Walking Control Utilized Redundancy for Biped Robot," *Proceeding of the 3rd France-Japan Congress & 1st Europe-Asia Congress on Mechatronics*, Vol. 2, pp. 453-458, 1996.
- [5] S. Stitt and Y. F. Zheng, "Distal Learning Applied to Biped Robots," *Proceeding of the IEEE International Conference on Robotics and Automation*, Vol. 1, pp. 137-142, 1994.