

Specifications:
 Current rating:1.0Amps
 Voltage rating:30V AC,DC
 Contact resistance:20m ohm Max
 Insulation resistance:1,000M ohm min.
 Dielectric Withstanding:750V AC/Minute
 Operating Temperature:-40°C ~ +105°C
 Materials:
 Insulator:Hiht Temperature Thermiplastic.Ul94V-0
 Contact:Copper Alloy
 Contact Plating:Contact area Gold Plated over
 50u"Nickel Plated and Solder tail 100u"
 Tin over 50u" Nickel Plated
 Shell:Copper Alloy With Tin Plated
 How To Order
 5075ABMR-05-SM

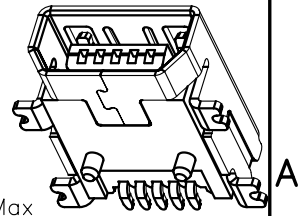

— SMD Type
 — No. Of Positions
 — Mini AB Type

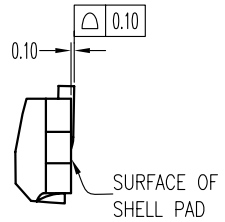
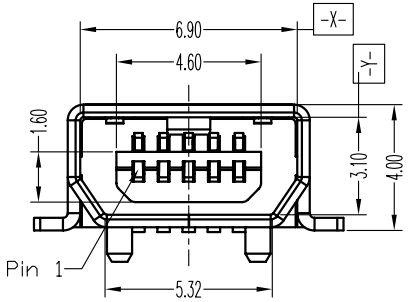

DETAIL A
 SCALE 2/1

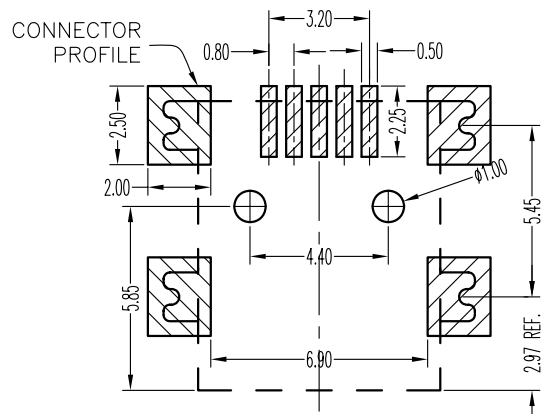

Recommended PCB Layout

RoHS Compliant

F				DRAWN: Cel king
E				CHECKED: Jeremy Liu
D	28-Sep-2005	ECN-CN050915	Cel king	APPROVAL: Mike Wu
C	28-Jul-2005	ECN-CN050728	Cel king	
B	26-JAN-2005	ECN-CN050130	JOY	
A	30-July-2004	(PC0001)	David Hu	
REV	DATE	FILE	BY	

GENERAL TOLERANCE: .X=±0.20 .XX=±0.15
UNIT: MM
SCALE:1:1
SHEET: 1 / 1
PROJECTION:



繼德工業股份有限公司
Neltron Industrial Co., Ltd.

DESCRIPTION: MINI USB 5S AB TYPE	SIZE A4
PART NO: 5075ABMR-05-SM	