

# UWB Test Report

By

Fanny Mlinarsky and John Ziegler

December 13, 2007

UWB Test Report .....	1
Background .....	2
UWB Applications.....	3
UWB Video Distribution .....	4
UWB Technology .....	5
Test Methodology .....	9
Test Results.....	10
Analysis of Results .....	17
Conclusion .....	18

With the recent media attention on UWB and the announcements of 22 UWB based Wireless-USB (W-USB) products being certified by the WiMedia Alliance, the time has come to evaluate this exciting new wireless technology and see if it has delivered on the promise of transporting hundreds of megabits per second and superior QoS.

This test was organized under the aegis of EE Times and our plan was to have a group of UWB companies collectively sponsor the test to promote their recently announced UWB products. UWB silicon providers and system vendors were invited to participate or to co-sponsor the test. Based on the wave of recent WiMedia certifications, we anticipated that the latest and greatest WiMedia reference designs would be submitted for the test. However, none of the WiMedia vendors chose to participate and we had to use off-the-shelf commercially available WiMedia W-USB products. The only sponsor and willing participant in the test was UWB silicon provider Pulse-LINK.

The Pulse-LINK CWave implementation focuses on video distribution and embodies the complete point-to-point and point-to-multipoint communication system with TCP/IP throughput of over 500 Mbps and reaching 890 Mbps at close range (figure 15). By comparison, the top throughput measured over the WiMedia links was an order of magnitude lower – around 50 Mbps at close range.

## Background

The initial public awareness of Ultra Wide Band (UWB) came about in February 2002 when the FCC allocated 7.5 GHz of spectrum – 3.1 to 10.6 GHz – for use by UWB devices, enabling this previously classified military technology to be commercialized, as had happened with CDMA years before.

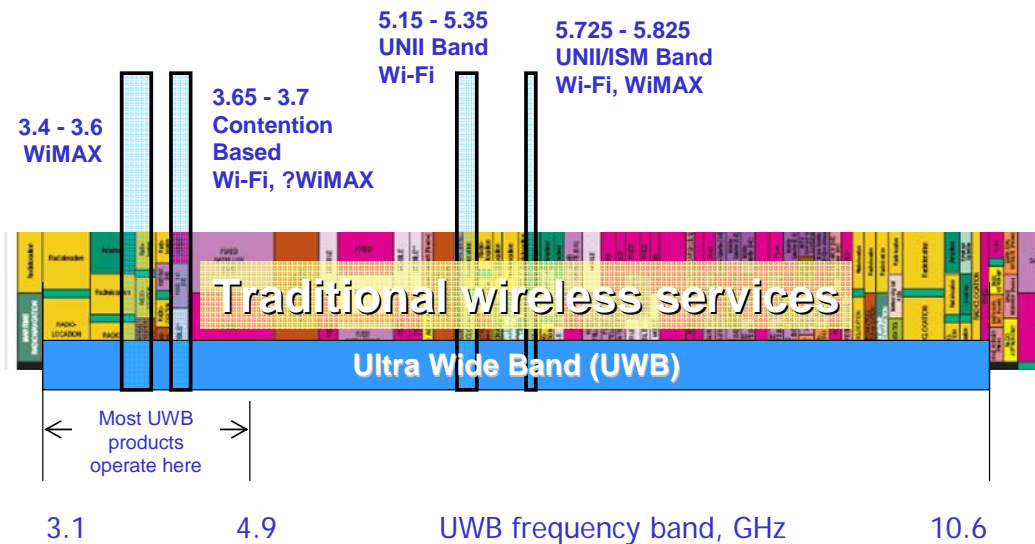

**Figure 1:** UWB operates in the noise floor of traditional wireless applications and is able to share the already allocated spectrum with other services while only negligibly raising their noise floor

The unique benefit of UWB signaling – its ability to operate at the noise floor – enables UWB devices to peacefully co-exist and share spectrum with traditional wireless services (figure 1). The low transmit power authorized by the FCC (table 1) curtailed the range of

UWB links to about 10 meters limiting this technology to Wireless Personal Area Networking (WPAN) applications. This range is not a fundamental limitation of UWB technology itself. If transmit power limits were increased the range of UWB would increase as well.

**Table 1:** *Indoor UWB emission limits in the US*

Frequency range (GHz)	Average EIRP* (dBm/MHz)	Mode
3.1-10.6	-41.3	Intentional
1.99-3.1	-51.3	Unintentional
1.61-1.99	-53.3	Unintentional
0.96-1.61	-76.3	Unintentional
<0.96	See Part 15.209	Unintentional

\* *Effective Isotropic Radiated Power*

The FCC approved the UWB spectrum allocation and transmit power limit, but did not specify an air interface, modulation or Media Access Controller (MAC) – specifications that were undertaken by the IEEE 802.15 committee in December of 2002 and abandoned in January of 2006 (see reference [2]). Today, UWB implementations are not constrained to any particular MAC or PHY and have the flexibility of using any MAC and PHY layers as long as they comply with the FCC spectrum mask limits.

Many of the companies originally working on the IEEE 802.15 standard joined the WiMedia Alliance creating their own specification of UWB based on OFDM PHY and a distributed USB-like MAC. This WiMedia specification was published as the European Computer Manufacturers Association ECMA-368 standard. Pulse-LINK developed and enhanced their original impulse-based UWB signaling and implemented their solution based on the IEEE 802.15.3b MAC.

## UWB Applications

While the original goal of 802.15.3 was wireless video distribution with QoS, the WiMedia Alliance has chosen to focus primarily on the PC-centric W-USB application.

Pulse-LINK, an early pioneer of UWB technology, focused on the original Consumer Electronics (CE) application of UWB – HD video distribution. Pulse-Link’s approach has an interesting twist in that they have developed their CWave architecture to work on both wireless and wired media such as coax, power-line and phone-line.

An innovative aspect of the CWave architecture is that any device using the Pulse-Link chipset is capable of supporting wireless, coaxial and power-line transmissions under a single 802.15.3b MAC, enabling HD video transport throughout the entire house on whatever media are available. The isochronous 802.15.3b MAC, with QoS built-in from the ground up, is designed to support whole-home networking of streaming video, multi-channel audio and high data rate networking.

Comparing PC-centric WiMedia products with CE-centric Pulse-LINK products may at first seem inappropriate, but with the rapid convergence of PC and CE devices the

mission of both solutions is to move bits fast and with QoS that supports high quality video, audio and data. It is the speed and quality of UWB transport that we set out to test.

## UWB Video Distribution

While Pulse-LINK persisted with the initial goal of 802.15.3 – streaming and distribution of HD content and multi-channel audio – the WiMedia group has at least initially strayed from this goal. Only two WiMedia vendors, Tzero and Sigma Designs, announced HD video distribution architectures. And while both companies have announced availability of UWB silicon as far back as CES 2005, neither of them have commercially available products and chose not to submit their reference designs for our test.

Our understanding is that WiMedia may embrace the video applications in the near future, but today most of the commercial WiMedia products are implementations of W-USB. One exception is the Toshiba port replicator that supports USB, Gigabit Ethernet and a video/audio link over a single UWB link, WiDV™, which is based on the WiMedia compatible air interface.

### Video distribution – throughput and network architecture considerations

Video content is transported and stored in a compressed format. Most broadcast and cable TV transmissions and conventional DVDs use MPEG-2 compression. H.264/MPEG-4 and JPEG 2000 are the emerging video compression formats that roughly double the efficiency of video transport and storage afforded by MPEG-2.

**Table 3:** *Throughput requirements for common video formats and resolutions*

Format		Average throughput required for high quality video	
		480i60	1080p30
Broadcast Cable TV	MPEG-2	8 Mbps	20 Mbps
Windows Media Video DivX XviD QuickTime	MPEG-4 Part 10/H.264	5 Mbps	12 Mbps

The video transport media in a typical home include coaxial, twisted pair, powerline and wireless. Wired video transmission technologies, such as HomePlug™ and HomePNA™ operate within a spectral mask below 30 MHz in order to meet the FCC emissions limit. Pulse-LINK pioneered the use of UWB over these wired media. The wide frequency band of UWB enables CWave to outperform HomePlug and HomePNA on their native media.

Further advantage of the multi-interface CWave architecture is that a single device can simultaneously support multiple media, including powerline now supported by HomePlug and coax and twisted pair now supported by HomePNA. CWave's TDMA

MAC can effectively bridge these disparate media by time-slicing the traffic over multiple network interfaces.

## UWB Technology

Today there are two predominant UWB solutions – WiMedia and CWave. The challenge for both technologies is to maximize the dynamic range of the link while still meeting the very low FCC transmit power threshold. Due to the wide spectrum of UWB, frequency-dependent tilt (figure 2) severely compromises the dynamic range of the link. Since RF attenuation increases with frequency, the wider the frequency band the more tilted the receive spectrum and the more dynamic range is lost to receive equalization or transmit pre-distortion.

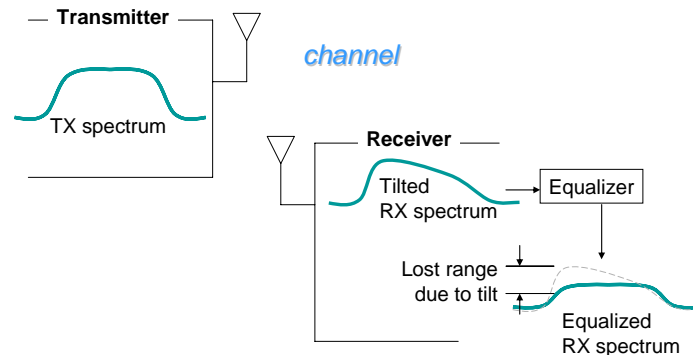

**Figure 2:** Channel tilt – the wider the channel the greater the attenuation tilt between high and low frequencies in the channel. To correct the tilt distortion, equalization can be performed in the receiver or reverse tilt pre-distortion can be done in the transmitter.

## WiMedia

The WiMedia specification broke up the available UWB spectrum into 5 Band Groups that are further subdivided into 528 MHz sub-bands (figure 3). Data transmissions can be frequency hopped among the three sub-bands to reduce the average transmit power while maximizing the instantaneous power of symbol transmissions. For example, the OFDM signal can be pulsed in the time domain over any of the 3 frequency sub-bands with one third duty cycle, thereby reducing the average transmit power by a factor of 3 or 4.77 dB. The WiMedia techniques for spreading the power include what WiMedia calls Time-Frequency Interleaving (TFI) and Fixed Frequency Interleaving (FFI). TFI is essentially a technique of frequency hopping the 528 MHz wide OFDM pulses over three bands. The FCC relaxed the -41.3 dBm/MHz limit to -36.5 dBm/MHz for peak power in the 528 MHz sub-bands since the 1/3 duty cycle averages to -41.3 dBm/MHz.

To avoid the UNII band 5.8 GHz interference from Wi-Fi, the current generation of WiMedia products operate in Band Group 1.

WiMedia uses MB-OFDM with data rates of 53.3, 80, 106.7, 160, 200, 320, 400 and 480 Mbps. QPSK modulation is used for data rates up to 200 Mbps and DCM (dual-carrier modulation) is used for data rates of 320 Mbps and higher. On the TX side a single 4 to 6 bit DAC running at 1 GHz is typically used to generate the 528 MHz TX spectrum and on the RX side two 4-bit, 1 GHz A/D converters (one for “I”, the other for “Q”

component) are typically required to detect and recover the MB-OFDM sub-carriers. One only has to look at the power consumption for these components alone to see this is not a low power technology and that it has substantial complexity in both the TX and RX sections.

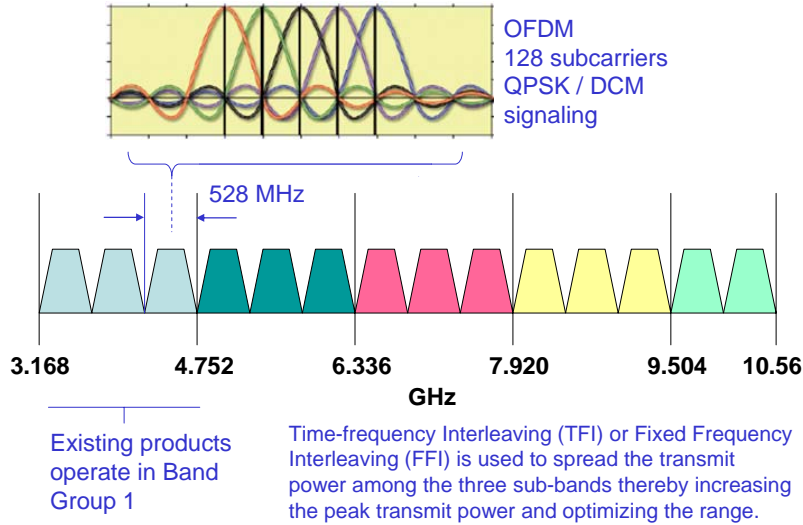

**Figure 3:** WiMedia MB-OFDM channel assignment in the 3.1 to 10.6 GHz band. Most existing products support Band Group 1. The 528 MHz OFDM sub-bands in each Band Group can be used to interleave the signal and spread its power.

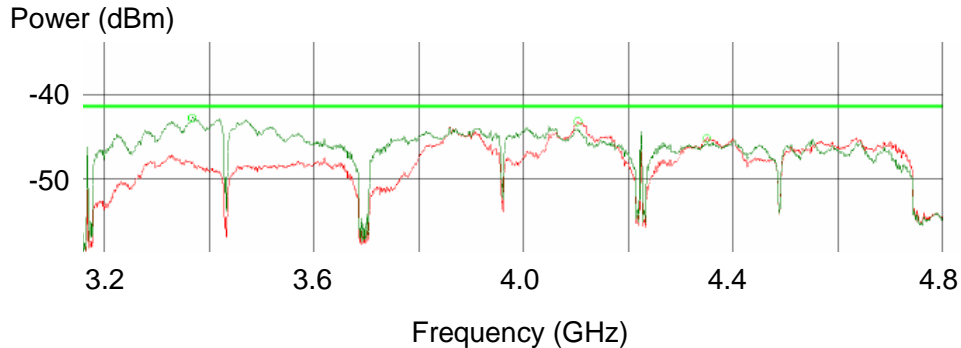
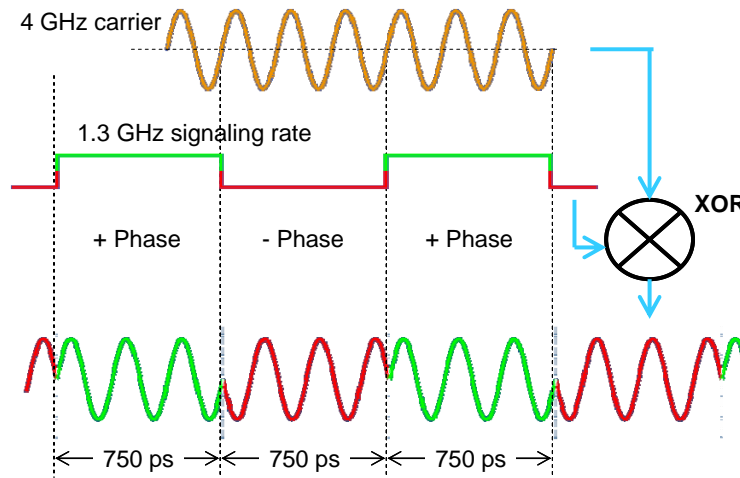

**Figure 4:** Example of the WiMedia Band Group 1 spectrum showing 3 sub-bands (adapted from an FCC report). For UWB spectrum measurement Agilent has provided E4440A PSA Series Spectrum Analyzer and ETS Lindgren has provided the Model 3117 Double-Ridged Waveguide Horn antenna. Both the analyzer and the antenna cover the entire 3.1 to 10.6 GHz range.

## CWave

Pulse-LINK’s CWave signaling scheme uses simple baseband pulses of ~750 ps to spread a bit’s total energy over the entire 1.35 GHz of spectrum. WiMedia’s more complex architecture uses longer 242 ns pulses requiring the baseband to calculate a 128 point FFT on 528 MHz of spectrum (table 2 of ECMA-368 specification). CWave’s considerably simpler architecture may explain why CWave’s overall performance appears to be an order of magnitude higher than WiMedia’s. Pulse-LINK claims much lower power consumption than WiMedia since their implementation avoids the use of

power-hungry converters. CWave uses single-carrier BPSK (binary phase shift keying) modulation (figure 5), which requires less stringent equalization than QPSK or DCM and thus can operate more robustly over a wide frequency band.



**Figure 5:** CWave modulation scheme – a single carrier BPSK using an XOR gate as the modulator. This example shows a 4 GHz carrier and the modulating waveform of 1.3 GHz. The integer multiple of the carrier cycles per data symbol assists with carrier recovery and enhances the robustness of this scheme.

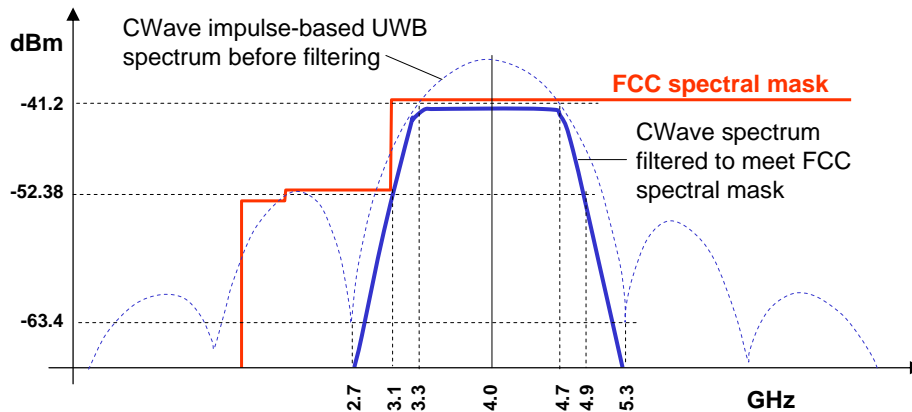

**Figure 6:** CWave spectrum. The unfiltered spectrum exhibits the characteristic  $\sin(x)/x$  shape of an impulse. The filtered CWave spectrum fits well within the FCC limit.

With a 4 GHz carrier the CWave  $\sin(x)/x$  shaped spectrum has nulls at 2.7 and 5.3 GHz (figure 6). The CWave spectrum can be moved anywhere within the 3.1 to 10.6 GHz FCC band by changing the carrier frequency. The bandwidth can be expanded or contracted by varying the frequency of the modulating signal (data rate). The current CWave reference design operating band is 3.3 to 4.7 GHz centered around 4 GHz.

CWave implemented a new cutting edge error correction algorithm known as Low-Density Parity Check Coding (LDPC) with FEC rates of  $\frac{1}{2}$ , and  $\frac{3}{4}$  (table 2). They claim it gives them lower power consumption and a substantial performance improvement over the traditional Reed-Solomon/Viterbi FEC used by WiMedia.

**Table 2:** Data rates supported by CWave

Operation	Transmitted Bit Rate (Mbps)*	FEC Rate	Spreading Factor
1	1350	1	1
2	1013	3/4	1
3	675	1/2	1
4	506	3/4	2
5	338	1/2	2
6	253	3/4	4
7	169	1/2	4
8	127	3/4	8
9	84	1/2	8
10	21	1	64
11	16	3/4	64
12	11	1/2	64

*\*The CWave reference design uses a 4.05 GHz carrier with the data rate values set to maintain the phase alignment between the carrier and the data signal at the XOR gate as shown in figure 5.*

CWave is capable of 1.35 Gbps of raw data rate. In our tests we were able to demonstrate actual data throughput approaching 900 Mbps at close range.

In addition to the wireless medium, CWave supports transport over 75 ohm coaxial cabling and CATV RF splitters installed in most homes. Pulse-Link claims support at similar data rates for transport over power lines and twisted pair cabling including telephone lines. octoScope did not test performance over power lines or twisted pair, but we look forward to testing these media the near future. Furthermore, CWave's isochronous 802.15.3b MAC and PHY have been down-selected by the membership of the Firewire 1394 Trade Association for extending 1394 functionality over coaxial networks within the home.

Architecturally, CWave appears to offer a significant advantage over the status quo of video transport products requiring disparate MACs to support different media:

- WiMedia UWB or Wi-Fi for wireless
- HomePNA for twisted pair
- MoCA™ (Multimedia over Coax Alliance) or HomePNA for coax
- HomePlug for powerline

It's a compelling idea to have one chip that is capable of supporting all the above media with one common platform:

- One chipset supports wireless, coax, power-line and phone-line
- One common MAC for a uniform QoS across all PHY media types
- MAC supports streaming high quality audio and HD video
- PHY layer bridging is inherent in the TDMA access scheme
- Up to 1 gigabit per second throughput on all PHY media
- Whole home connectivity



The CWave 802.15.3b MAC using its TDMA channel access scheme can time-slice traffic, enabling a single multi-port device to route video and data streams among disparate media in the home. Given the ample throughput of CWave, several simultaneous 1080p streams can be sent around the house time-multiplexed on multiple network interfaces and over multiple media. Thus, a single CWave chipset can replace multiple network chips for transport of digital content wirelessly, over coax, power-line and phone-line.

Pulse-LINK's CWave 802.15.3b MAC was designed from the ground up to support the QoS demands of isochronous streaming of audio, HD video and High Data Rate digital networking across all available PHY transports media within the home.

## Test Methodology

This test focused on measuring UWB throughput over wireless and coaxial media. We have uploaded the latest drivers for all the devices under test from the manufacturer's web sites. We used IxChariot for TCP throughput measurements when an Ethernet port was available and the file transfer method (figure 7) when only a USB port was available.



**Figure 7: W-USB test configuration**  
*Throughput of W-USB products was measured by timing the file transfer via the W-USB link between the host wireless adapter (HWA) and the device wireless adapter (DWA).*

Read and write cycles of a 419 MB file were timed and averaged over several cycles. The fastest WiMedia file transfer we measured lasted 57 seconds. If we assume a 1 second error in registering of the file transfer time, our measurement accuracy is better than +/- 2%.

Since lower than expected throughput was measured on the WiMedia products, we have repeated the tests on these products at two different houses and our measurements passed the sanity check.

For devices supporting Ethernet – Toshiba port replicator and CWave – IxChariot was used to measure TCP throughput via the Ethernet port (figures 8, 11). We used the filesndl.scr and ultra\_high\_performance\_throughput.scr Chariot scripts in our testing.

Since the Toshiba port replicator supports both USB and Gigabit Ethernet in addition to the video and audio streams, we tested the throughput of the Toshiba WiMedia link in a couple of ways. First we performed the file transfers over the USB port and then we ran the Chariot TCP throughput test over the Gigabit Ethernet port. We also combined the Chariot test of the Gigabit Ethernet port with the file transfer test on the USB port to measure the combined throughput on the two ports operating together. We have not connected the display while performing the measurements on the data ports since the display drastically limited the range of operation for the WiQuest UWB link.

## Test Results

Most of the WiMedia devices in the test were implementations of Wireless USB (W-USB) with the exception of the Toshiba R400 laptop and Pulse-LINK CWave (table 4). Pulse-LINK's CWave was the only UWB device capable of multi-stream HD video transport and the only device supporting coaxial cabling in addition to wireless.

**Table 4:** UWB products tested

Device 1 / HWA	Device 2 / DWA	Chipset	
CWave Wireless PL3100-EVK00 S/N: 0042 Driver: 4.22	CWave Wireless PL3100-EVK00 S/N: 0029	Pulse-LINK	
CWave Coax PL3100-EVK01 S/N: 0033 Driver: 4.22	CWave Coax PL3100-EVK01 S/N: 0017		
IOGEAR Wireless USB Hub GUWH104 S/N: OU78USQ1100377 S/N: OU78USQ1100348 Driver: 1.0-10393	IOGEAR Wireless USB Adapter GUWA100U S/N: OU78USQ1100377 S/N: OU78USQ1100348	Alereon PHY only	
Belkin Wireless USB 2.0 4-Port Hub F5U302-HUB S/N: 15073200479 Ver: 111111 Driver: 1.3.98.1	Belkin Wireless USB 2.0 Dongle FSU302-DNGL S/N: 15073200042 Ver: 111111	WiQuest in the hub	
Belkin Wireless Belkin Cable Free USB 2.0 4-Port Hub F5U301-HUB S/N: 00173F219492 Driver: 1.1.0.0	Belkin Wireless Belkin Cable Free USB 2.0 Dongle FSU301-DNGL S/N: 00173F219492	Wisair	
Y-E Data YD-300D UWB USB 4-Port Hub S/N: 001UWAA1001 Driver: 1.1.0.0	Y-E Data YD-300H UWB USB Host S/N: 001UWAA1002	Wisair	
Toshiba Portege Notebook PC R400-S4933 Part #: PPR40U-00U015 Driver: 3.8.3.7	Toshiba Wireless UWB Port Replicator PA3529U-2PRP S/N: 8272R000193	WiQuest	

## W-USB performance

Figure 14 shows the performance of the W-USB products in the test. The throughput of the Belkin FSU302 W-USB link was the highest W-USB throughput measured with around 50 Mbps at close range.

## Toshiba R400 performance

Toshiba R400 laptop features a built-in UWB link to its port replicator. This link is based on WiDV™, the WiMedia compatible UWB technology from WiQuest. The port replicator supports Gigabit Ethernet, W-USB, display and audio over a single WiMedia link to the laptop.

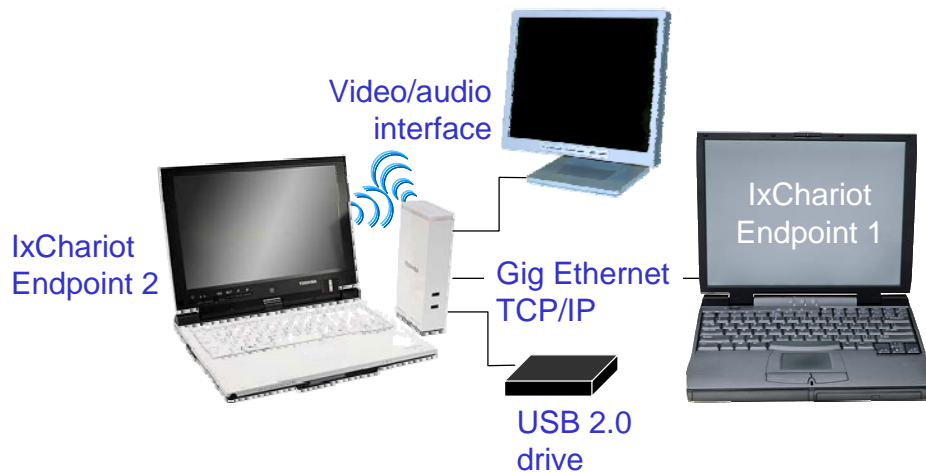

**Figure 8:** Test setup for measuring throughput of the Toshiba docking station that interfaces the laptop via a single WiMedia connection to the Gigabit Ethernet port, USB port and video/audio devices

The Gigabit Ethernet only, the USB only and the combined throughput measurements of the Toshiba port replicator were under 25 Mbps at close range (figures 9, 14, 15).



**Figure 9:** Toshiba throughput over the WiMedia link between the port replicator and the laptop. This test started with the IxChariot TCP/IP throughput via the Gigabit Ethernet port and then a USB file transfer was initiated over the USB port. The IxChariot plot shows the throughput on the Gigabit Ethernet port dropping from 16.8 Mbps when operating alone to 6.8 Mbps when operating in conjunction with the USB port transferring a file.

The fact that the throughput of the Gigabit Ethernet port drops during the file transfer on the USB port may mean that Toshiba purposefully manages bandwidth allocation among the Gigabit Ethernet, USB and video/audio interfaces sharing the WiMedia link.

It is difficult to judge how much bandwidth on the WiDV™ interface is allocated to the video stream. At optimum antenna orientations video links were achievable up to distances of 24 to 30 inches, but the quality of the display at this distance was sub-optimum exhibiting a waviness that makes reading the text difficult. The waviness becomes imperceptible at the distance of about 12 inches.

The WiQuest WiDV™ chipset used to implement the Toshiba WiMedia interface uses a proprietary video compression that may be based on the wavelet method, similar to the Analog Devices JPEG 2000. WiQuest claims a factor of 5 video compression reducing the raw SXGA video throughput of 1.8 Gbps (1280 x 1024 x 24 bits x 60 Hz = 1.8 Gbps) down to 377 Mbps. We were unable to verify the actual throughput on the video link. However, the distortion of the image observed at 24 to 30 inches of distance between the port replicator and the laptop was symptomatic of wavelet video compression at a throughput limited to approximately 30 to 40 Mbps. In order to optimize display quality, the Toshiba port replicator documentation specifies a distance limit of 0.5m (19.7”).

### CWave performance

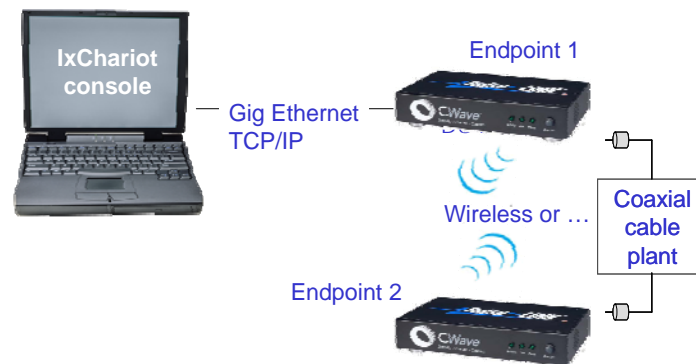

**Figure 10: CWave test setup** for measuring TCP/IP throughput with the IxChariot

CWave throughput measurements were performed using IxChariot (figure 10) over wireless and coaxial media. As a sanity check, we also measured the throughput using iPerf with similar results. The coaxial cabling included some common configurations of the typical RG-59 installations with one or two splitters and also using the high grade RG-6 coaxial cabling to show the supportable range of HD video transmission in the home, which in our test exceeded 525 feet of cabling (table 5).

Although higher transmit power could have been used over RG-6 without violating the FCC emissions limits, we have not adjusted the power and thus have not exercised the coaxial cable length supportable by CWave to its full extent.

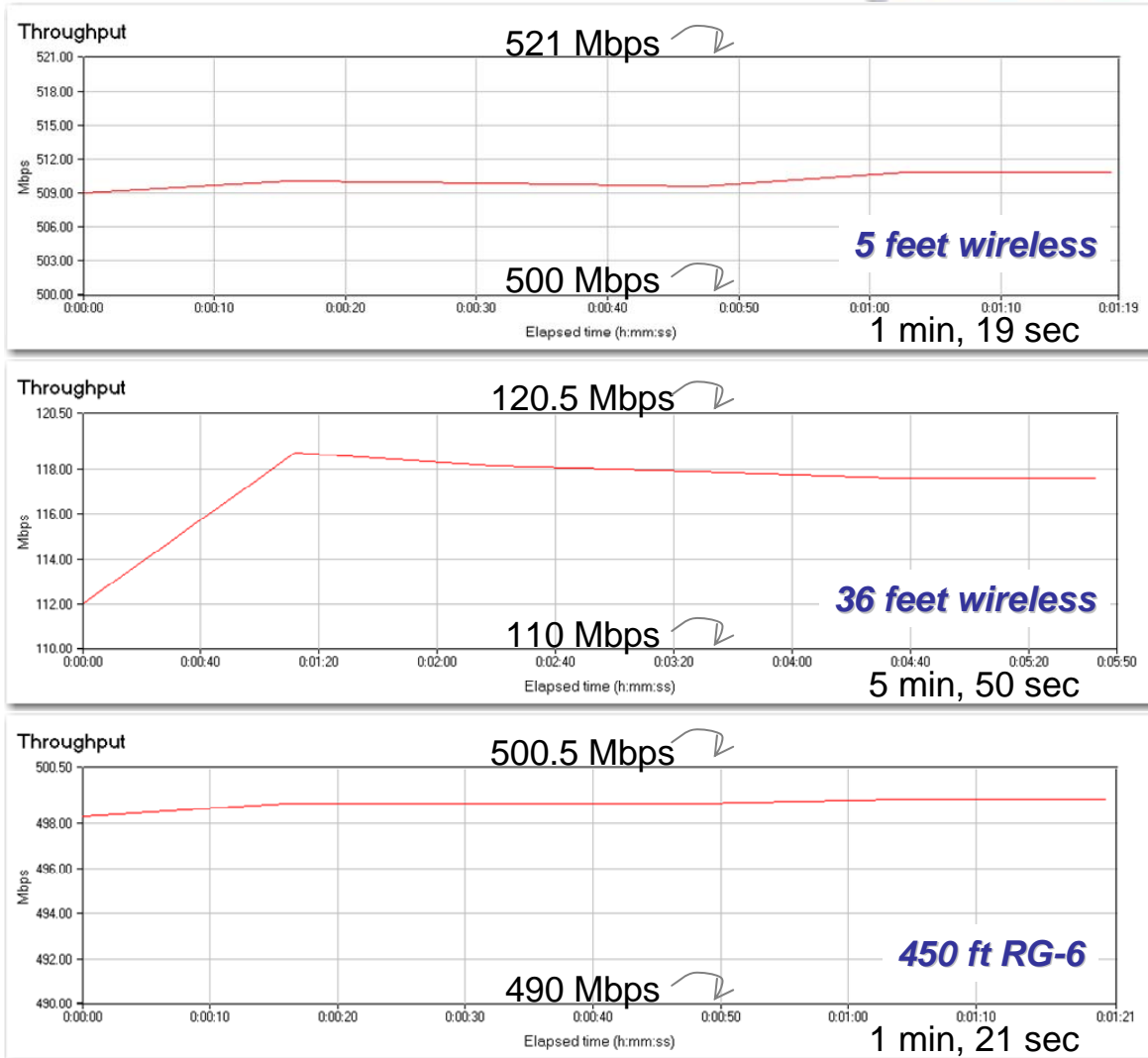
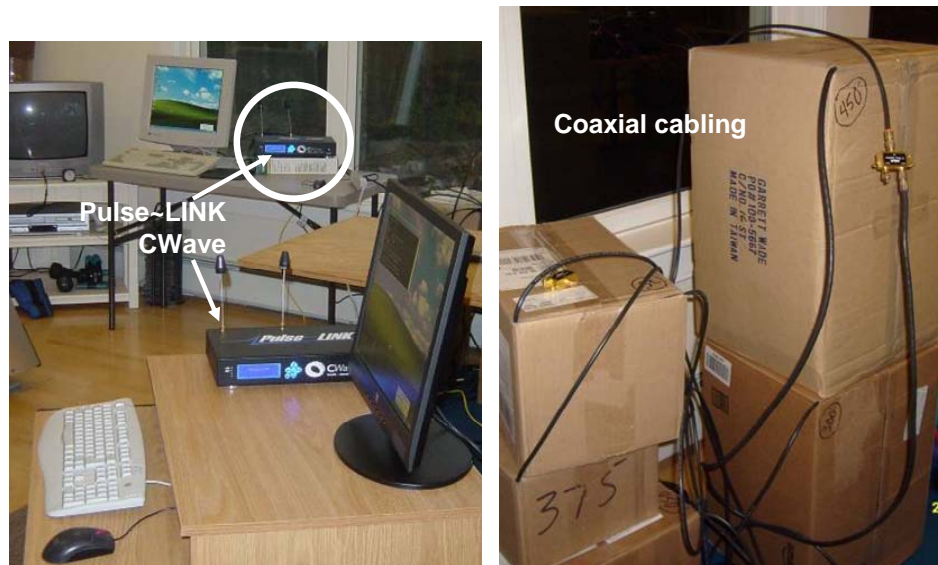

**Figure 11:** IxChariot plots of CWave performance over wireless and coaxial media

The CWave throughput held at around 500 Mbps at up to 8 feet of wireless range and over much of the coaxial range (figures 11, 13 and table 5). The CWave throughput dropped off to about 115 Mbps at the wireless distance of 13 feet and this throughput was maintained up to 40 feet, at which point we ran out of space in the test facility. We were able to measure 890 Mbps of throughput at a distance of 1 foot using the Pulse-LINK throughput test that give us results similar to IxChariot. However, the Pulse-LINK TCP/IP interface was unable to operate at this data rate. It is our understanding that Pulse-LINK is still optimizing the data rate adaptation algorithm and that the throughput vs. distance performance is expected to improve.



**Figure 12: Photos of test setups** – left: *Toshiba laptop and its port replicator*; right: *Y-E Data W-USB test setup with the USB drive used to copy the file. The Toshiba port replicator data ports were tested without the display connected since the display drastically limited the range of operation.*



**Figure 13: Pulse-LINK test setup** Left: *CWave wireless modules*; right: *coaxial cable plant with segments of cable packed into boxes and interconnected with external splitters.*

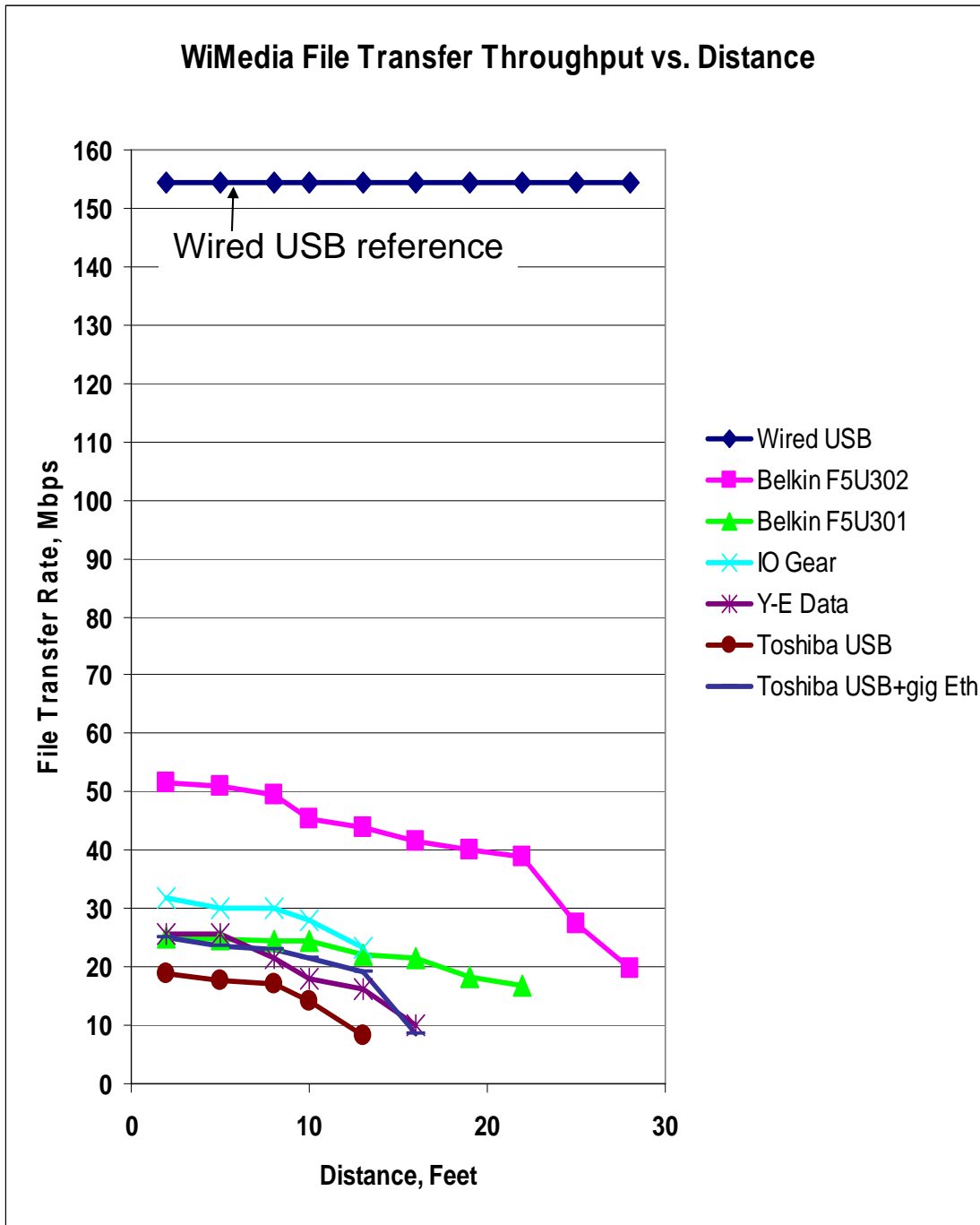

**Figure 14:** WiMedia file transfer throughput vs. distance with the wired USB throughput reference. The values are average of file read and write transfers. The 'Toshiba USB+gig Eth' plot shows the combined throughput of the Gigabit Ethernet port and the USB file transfer.

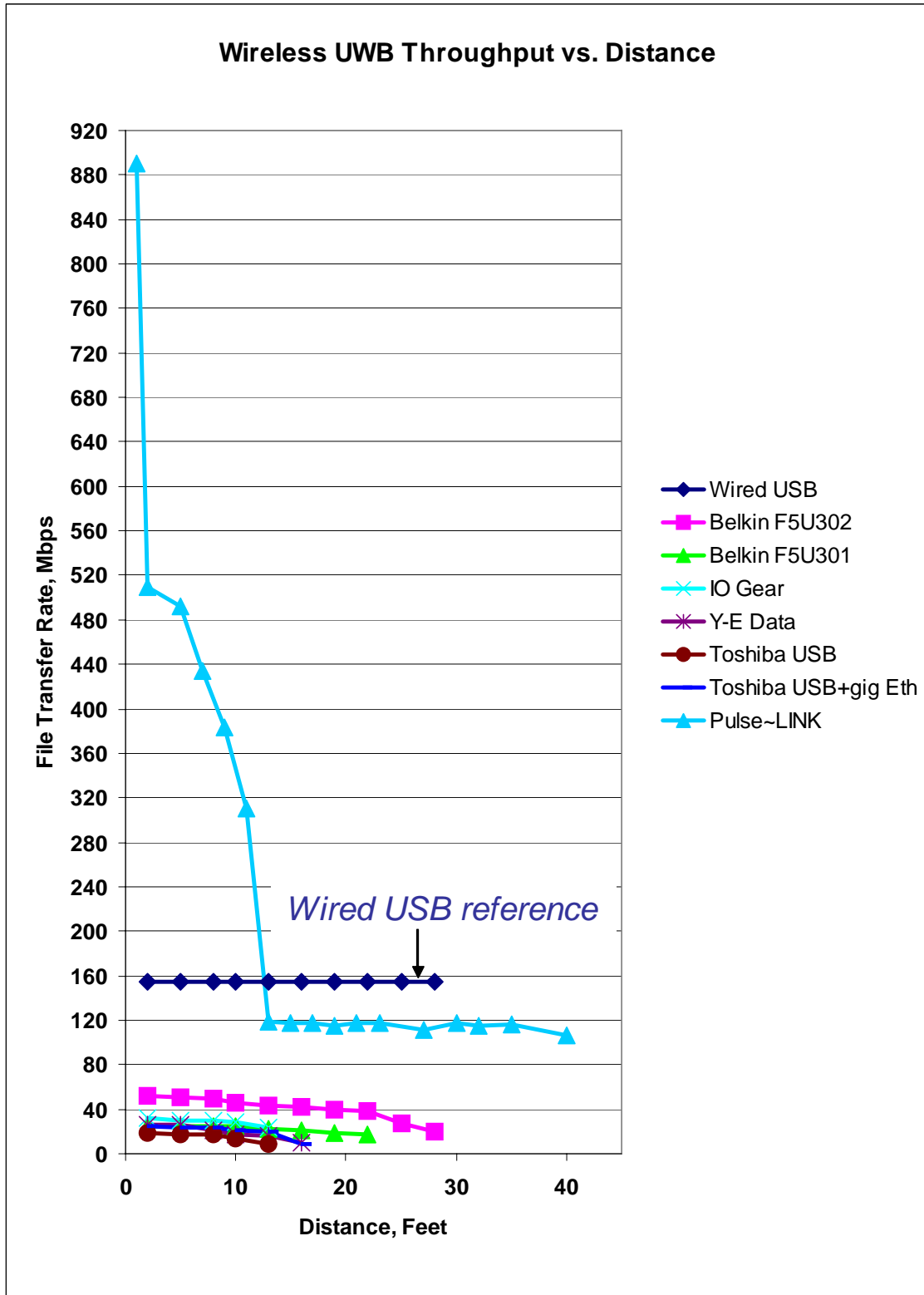

**Figure 15:** Wireless UWB throughput vs. distance including the Pulse-LINK throughput. The Pulse-LINK device reached 890 Mbps at short range

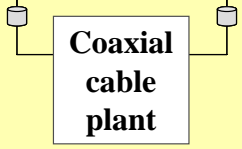
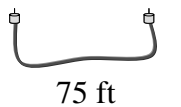
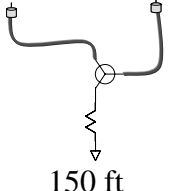
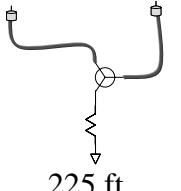
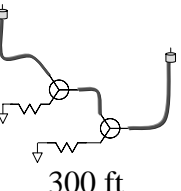
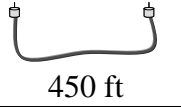
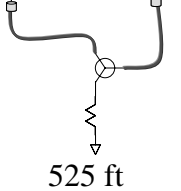

**Table 5: Pulse-LINK coaxial performance**

Average TCP Throughput	Cable 1 Cable 2 Cable 3	# of Splitters* 	Coaxial cable plant 
<b>498 Mbps</b>	RG-59, 75 ft	0	 75 ft
<b>497 Mbps</b>	RG-59, 75 ft	1	 150 ft
	RG-59, 75 ft		
<b>497 Mbps</b>	RG-59, 150 ft	1	 225 ft
	RG-59, 75 ft		
<b>499 Mbps</b>	RG-59, 150 ft	2	 300 ft
	RG-59, 75 ft		
	RG-59, 75 ft		
<b>499 Mbps</b>	RG-6, 450 ft	0	 450 ft
<b>115 Mbps</b>	RG-6, 450 ft	1	 525 ft
	RG-59, 75 ft		

\* RCA 2-Way Signal Splitter VH47, 5 to 900 MHz

## Analysis of Results

While questions remain about the reasons for the low levels of throughput exhibited by the WiMedia devices, we were impressed by the performance of CWave.

Regarding the lower than expected throughput of WiMedia, while it is possible that early drivers are to blame, it is difficult to explain the 10:1 ratio of the claimed data rate (480 Mbps) to the actual measured throughput. We were, after all, measuring a point-to-point link with little overhead for medium access. We were transferring a very large file (419

MB) and one would hope that even a bad driver would send maximum size frames for such a transfer, incurring minimal MAC and driver overhead. Still, the top WiMedia transfer rate was about a third of what we measured over the wired USB for the same file and with the same USB disk drive.

The WiMedia vendors claim that the low throughput is caused by the need to interface the wireless driver through the existing USB drivers in the PCs. They expect throughput to improve by a factor of 2:1 on the HWA and DWA sides of the link (a 4:1 combined improvement) when native drivers are implemented. We were unable to validate their claims, but are ready to perform another test on the next generation of devices.

WiMedia data throughput issues aside, the limited range of WiMedia devices is another cause for concern. Even accepting the limited throughput as a driver related issue, the short range is solely a function of WiMedia's radio performance.

At this point, it seems more probable that the simplicity of the original impulse-based modulation may explain the robustness and performance advantages of CWave over WiMedia.

## **Conclusion**

We have measured early UWB implementations using two key technologies available today: CWave and WiMedia. While WiMedia has been implemented by the majority of UWB vendors, this technology so far has demonstrated less than optimum performance. Has most of the market made a mistake following one another into the WiMedia camp? WiMedia vendors tell us that new and more capable products are on the way. We are ready to run another test that may demonstrate the true potential of WiMedia.

The results we have today reveal that the original pulse-based UWB modulation implemented by Pulse-LINK stands high above the WiMedia crowd with 500+ Mbps application layer throughput for CWave vs. 50 Mbps application layer throughput for WiMedia. Pulse-LINK's CWave technology has delivered on the promise of UWB – HD video distribution.

With over 500 Mbps of wireless and coaxial throughput and a powerful QoS enabled MAC capable of controlled and predictable performance over multiple media in the house, CWave appears to be the clear technology leader in home networking and is well positioned to emerge as the 21<sup>st</sup> century architecture for full-home multimedia connectivity.

### *Acknowledgements:*

We would like to thank Agilent, ETS-Lindgren and Ixia for providing the equipment for our test. Agilent has provided the E4440A PSA Series Spectrum Analyzer and ETS Lindgren has provided Model 3117 Double-Ridged Waveguide Horn antenna for UWB spectrum measurements. Both the analyzer and the antenna cover the entire UWB frequency band from 3.1 to 10.6 GHz. Ixia has provided IxChariot for IP layer throughput measurements.

*References:*

- [1] EE Times print publication, December 10, 2007
- [2] EE Times Wireless Net Designline sidebar to this report on the IEEE 802.15.3 standardization story, <http://www.wirelessnetdesignline.com/howto/204703822>
- [3] EE Times Wireless Net Designline publication of this report in 3 parts, <http://www.wirelessnetdesignline.com/howto/204703840;jsessionid=33LOHZNQR4IHIQSNDLRSKH0CJUNN2JVN>

*Authors:*

**Fanny Mlinarsky** ([fm@octoscope.com](mailto:fm@octoscope.com)) is the President of octoScope, a consulting firm focusing on architecture and performance of wireless data communications systems.

**John Ziegler** ([john.ziegler@octoscope.com](mailto:john.ziegler@octoscope.com)) is a data communications software development consultant with experience in communications protocols including 802.11, SIP, and a variety of voice and video technologies.

*Contact:*

Fanny Mlinarsky  
octoScope, Inc.  
Bolton, MA  
[fm@octoscope.com](mailto:fm@octoscope.com)  
978-376-5841