

# A Universal Stability Criterion of the Foot Contact of Legged Robots - Adios ZMP

Hirohisa Hirukawa

Shizuko Hattori

Kensuke Harada

Shuuji Kajita

Kenji Kaneko

Fumio Kanehiro

Kiyoshi Fujiwara

Mitsuharu Morisawa

Intelligent Systems Institute

National Institute of Advanced Industrial Science and Technology (AIST)

Tsukuba, Japan 305-8568

Email: {hiro.hirukawa,s.hattori,kensuke.harada,s.kajita,k.kaneko,f.kanehiro,k.fujiwar,m.morisawa} @aist.go.jp

**Abstract**— This paper proposes a universal stability criterion of the foot contact of legged robots. The proposed method checks if the sum of the gravity and the inertia wrench applied to the COG of the robot, which is proposed to be the stability criterion, is inside the polyhedral convex cone of the contact wrench between the feet of a robot and its environment. The criterion can be used to determine the strong stability of the foot contact when a robot walks on an arbitrary terrain and/or when the hands of the robot are in contact with it under the sufficient friction assumption. The determination is equivalent to check if the ZMP is inside the support polygon of the feet when the robot walks on a horizontal plane with sufficient friction. The criterion can also be used to determine if the foot contact is sufficiently weakly stable when the friction follows a physical law. Therefore, the proposed criterion can be used to judge what the ZMP can, and it can be used in more universal cases.

## I. INTRODUCTION

The stability of the foot contact of a legged robot can be determined by checking the ZMP[10] is inside the support polygon of the feet of the robot without solving the equations of motions when the robot is walking on a horizontal plane with sufficient friction. But a legged robot may walk on stairs or a rough terrain, and/or move using its hands as well as its feet. Besides, the friction between the robot and the environment may not be enough to prevent the robot from slipping. Is it possible to determine the contact stability in the cases without solving the equations of motions?

This paper studies the question and concludes that the contact stability can be determined in the strongly stable sense[7] when the friction is assumed to be sufficient and in the weakly stable sense[7] without the assumption. The stability is determined by checking if the sum of the gravity and the inertia wrench applied to the COG of the robot is inside the polyhedral convex cone of the contact wrench between the feet of a robot and its environment. It is proved that the determination is equivalent to check if the ZMP is inside the support polygon of the feet when the robot walks on a horizontal floor with sufficient friction. This paper proposes to

let the sum of the gravity and the inertia wrench applied to the COG of the robot be the stability criterion of the foot contact of legged robots. The contact stability can be determined by checking if the criterion is inside the polyhedral convex cone of the contact wrench in the senses mentioned above. The goal of the paper is to say “Adios ZMP”.

This paper is organized as follows. Section 2 reviews the related works. Section 3 gives the proof of the results of the paper. Section 4 presents a walking pattern generator of a biped robot as an application of the proposed criterion. Section 5 concludes the paper.

## II. RELATED WORKS

Goswami proposed FRI (Foot Rotation Indicator) to judge the contact stability and evaluate how much moment is applied to break the contact when a robot is supported by single foot[2]. Yoneda et al. presented a method to determine if a robot should rotate about a contacting edge which may not be horizontal[11]. Harada et al. proposed a generalized ZMP to determine the contact stability when the hands of a robot are in contact with the environment as well as its feet [3]. Saida et al. considered the feasible solution of contact wrench (FSW), which is essentially same as the criterion proposed here. But neither rigorous proof was given to relate the FSW to the contact stability, and nor method was proposed to generate motion patterns based on it[8].

The contact stability problem has also been studied intensively in the community of mechanical assembly to design the optimal fixture, and the methods to determine the stability have been proposed with rigorous proof in which the Coulomb friction is assumed[1], [7], [9]. The results can be applied to the problem considered here if the dynamic problem can be reduced to a static equilibrium problem based on the D’Alembert principle as shown in the following. We also show how to generate motion patterns of legged robots based on the criterion.

### III. STABILITY CRITERION OF THE FOOT CONTACT

#### A. Definitions

1) *Coordinates:* Fig. 1 illustrates a legged robot whose hands may be in contact with the environment. Let  $\Sigma_R$  be

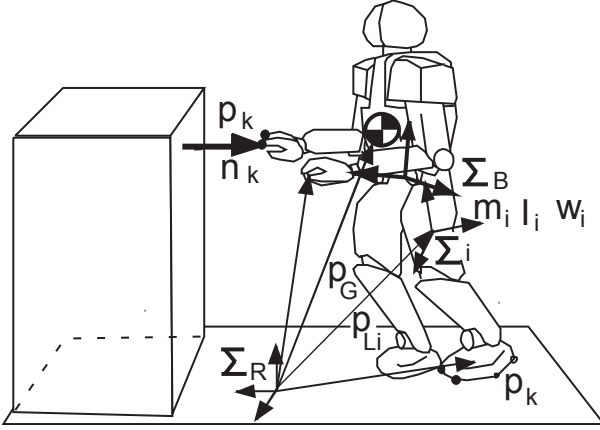

Fig. 1. Model of the System

the reference frame,  $\Sigma_B$  a frame fixed to the waist of the robot, and  $\Sigma_{L_i}$  a frame fixed to the COG of the  $i$ -th link of the robot ( $i = 1, \dots, N$ ).

Let  $\mathbf{p}_{L_i} (= [x_{L_i} \ y_{L_i} \ z_{L_i}]^T)$  be the origin  $\Sigma_{L_i}$  and  $\mathbf{p}_B (= [x_B \ y_B \ z_B]^T)$  that of  $\Sigma_B$  with respect to  $\Sigma_R$ . In the following, the position vectors are represented with respect to  $\Sigma_R$  unless otherwise specified. Let  $\mathbf{p}_k$  ( $k = 1, \dots, K$ ) be the vertices of the support polygons of the hands and feet, and  $\mathbf{p}_G (= [x_G \ y_G \ z_G]^T)$  the position of the COG of the robot.  $\mathbf{p}_G = \sum_{i=1}^N m_i \mathbf{p}_{L_i} / \sum_{i=1}^N m_i$ , where  $m_i$  is the mass of the  $i$ -th link.

Let  $\mathbf{f}_k$  be the force applied to the robot at  $\mathbf{p}_k$ , and  $\mathbf{n}_k$  the unit normal vector at  $\mathbf{p}_k$  pointed to the robot.  $\mathbf{I}_i$  and  $\boldsymbol{\omega}_i$  denote the inertia tensor and the angular velocity of the  $i$ -th link with respect to  $\Sigma_R$  respectively.

2) *Gravity and the inertia force and torque to the robot:*

Let the sum of the gravity and the inertia force applied to the robot be  $\mathbf{f}_G$  and the sum of the moments about the COG of the robot  $\boldsymbol{\tau}_G$  with respect to  $\Sigma_R$ , which can be given by

$$\mathbf{f}_G = M(\mathbf{g} - \ddot{\mathbf{p}}_G), \quad (1)$$

$$\boldsymbol{\tau}_G = \mathbf{p}_G \times M(\mathbf{g} - \ddot{\mathbf{p}}_G) - \dot{\mathcal{L}}, \quad (2)$$

where  $M = \sum_{i=1}^N m_i$  is the total mass of the robot,  $\mathbf{g} = [0 \ 0 \ -g]^T$  the gravity vector, and  $\mathcal{L} (= [\mathcal{L}_x \ \mathcal{L}_y \ \mathcal{L}_z]^T)$  the angular momentum of the robot with respect to the COG defined by

$$\mathcal{L} = \sum_{i=1}^N \{m_i(\mathbf{p}_{L_i} - \mathbf{p}_G) \times \dot{\mathbf{p}}_{L_i} + \mathbf{I}_i \boldsymbol{\omega}_i\}. \quad (3)$$

3) *Set of the contact force and torque from the environment:*

Let  $\mathbf{f}_C$  be the contact force which can be applied from the environment to the robot with respect to  $\Sigma_R$  and  $\boldsymbol{\tau}_C$  the corresponding moment. The set of  $(\mathbf{f}_C, \boldsymbol{\tau}_C)$  can be given by

$$\mathbf{f}_C = \sum_{k=1}^K \sum_{l=1}^L \epsilon_k^l (\mathbf{n}_k + \mu_k \mathbf{t}_k^l), \quad (4)$$

$$\boldsymbol{\tau}_C = \sum_{k=1}^K \sum_{l=1}^L \epsilon_k^l \mathbf{p}_k \times (\mathbf{n}_k + \mu_k \mathbf{t}_k^l), \quad (5)$$

where the friction cone at  $\mathbf{p}_k$  is approximated by a  $L$ -polyhedral cone,  $\mathbf{t}_k^l$  is a unit tangent vector to make  $\mathbf{n}_k + \mu_k \mathbf{t}_k^l$  be the  $l$ -th edge of the polyhedral cone,  $\mu_k$  the friction coefficient at  $\mathbf{p}_k$ , and  $\epsilon_k^l$  a nonnegative scalar.  $\epsilon_k^l$  gives the magnitude of the force of the  $l$ -th edge of the approximated friction cone at the  $k$ -th contact point.

The set of  $(\mathbf{f}_C, \boldsymbol{\tau}_C)$  forms a polyhedral convex cone in the space of the contact force and torque, and is called a *polyhedral convex cone of the contact wrench* here.

4) *Strong stability and weak stability:* The definitions of the strong stability and weak stability[7] can be applied to our problem as follows.

*Definition 1:* The contact between the robot and the environment is *strongly stable* when it is guaranteed that the contact is stable to  $(\mathbf{f}_G, \boldsymbol{\tau}_G)$ . The contact is *weakly stable* when it is possible that the contact is stable to  $(\mathbf{f}_G, \boldsymbol{\tau}_G)$ . The contact is *strongly unstable* when it is not weakly stable.

The strong stability can not always be determined since the contact force is indeterminate in general. The contact is always weakly stable in our problem when the motion of the robot is feasible as we discuss in the following.

#### B. Strong stability determination

Let us assume that sufficient friction exists at the contact. The assumption implies that an arbitrary friction force can be generated at every contact point independent to the normal force at the point, and it can be written by

$$\mathbf{f}_C = \sum_{k=1}^K (\epsilon_k^0 \mathbf{n}_k + \sum_{l=1}^4 \epsilon_k^l \mathbf{t}_k^l), \quad (6)$$

$$\boldsymbol{\tau}_C = \sum_{k=1}^K \mathbf{p}_k \times (\epsilon_k^0 \mathbf{n}_k + \sum_{l=1}^4 \epsilon_k^l \mathbf{t}_k^l), \quad (7)$$

where  $\mathbf{t}_k^l$  ( $l = 1, \dots, 4$ ) are the unit tangent vectors at  $\mathbf{p}_k$  whose nonnegative linear combination spans the tangent plane. Then the strong contact stability can be determined as follows.

**Theorem 1: (Strong stability criterion)** If  $(-\mathbf{f}_G, -\boldsymbol{\tau}_G)$  is an internal element of the polyhedral convex cone of the contact wrench given by Eqs.(6) and (7), then the contact is strongly stable to  $(\mathbf{f}_G, \boldsymbol{\tau}_G)$ .

(proof) Let  $(\Delta \mathbf{x}_G, \boldsymbol{\Omega}_G)$  be an admissible infinitesimal translation and rotation of  $\mathbf{p}_G$ . Then  $(\Delta \mathbf{x}_G, \boldsymbol{\Omega}_G)$  must satisfy

$$\forall k; \left( \begin{array}{cc} \mathbf{n}_k^T & (\mathbf{p}_k \times \mathbf{n}_k)^T \end{array} \right) \left( \begin{array}{c} \Delta \mathbf{x}_G \\ \boldsymbol{\Omega}_G \end{array} \right) \geq 0, \quad (8)$$

$$\forall k, l; \left( \begin{array}{cc} (\mathbf{t}_k^l)^T & (\mathbf{p}_k \times \mathbf{t}_k^l)^T \end{array} \right) \left( \begin{array}{c} \Delta \mathbf{x}_G \\ \boldsymbol{\Omega}_G \end{array} \right) \geq 0, \quad (9)$$

to prevent the robot from penetrating into the environment at  $\mathbf{p}_k$  and from slipping respectively. The inequalities must hold at all of  $\mathbf{p}_k$  ( $k = 1, \dots, K$ ) and forms homogeneous linear

inequalities. The solution of homogeneous linear inequalities is a polyhedral convex cone that can be written by

$$\begin{pmatrix} \Delta \mathbf{x}_G \\ \boldsymbol{\Omega}_G \end{pmatrix} = \sum_{q=1}^Q \mathbf{e}_q \delta_q, \quad (10)$$

where  $\mathbf{e}_q : 6 \times 1$  is the  $q$ -th edge of the cone,  $\delta_q$  an arbitrary nonnegative scalar, and  $M$  the number of the edges. Let the solution set be  $S_1(\delta \mathbf{x}_G, \boldsymbol{\Omega}_G)$ , then

$$\forall k, n; \quad (\mathbf{n}_k^T \quad (\mathbf{p}_k \times \mathbf{n}_k)^T) \mathbf{e}_q \geq 0, \quad (11)$$

$$\forall k, l, n; \quad (\mathbf{t}_k^l)^T \quad (\mathbf{p}_k \times \mathbf{t}_k^l)^T) \mathbf{e}_q \geq 0, \quad (12)$$

hold, since  $\delta_q$  may take an arbitrary nonnegative number.

Let  $S_2(\mathbf{f}_C, \boldsymbol{\tau}_C)$  be the set of  $(\mathbf{f}_C, \boldsymbol{\tau}_C)$  given by Eqs.(6) and (7). Eqs.(10), (11) and (12) imply that

$$\begin{aligned} \forall (\delta \mathbf{x}_G, \boldsymbol{\Omega}_G) \in S_1, \forall (\mathbf{f}_C, \boldsymbol{\tau}_C) \in S_2; \\ (\mathbf{f}_C)^T \quad (\boldsymbol{\tau}_C)^T) \begin{pmatrix} \Delta \mathbf{x}_G \\ \boldsymbol{\Omega}_G \end{pmatrix} \geq 0. \end{aligned} \quad (13)$$

From the inequality and Eq.(10),  $S_2(\mathbf{f}_C, \boldsymbol{\tau}_C)$  is the solution of homogeneous linear inequalities

$$\begin{pmatrix} \mathbf{e}_1^T \\ \vdots \\ \mathbf{e}_Q^T \end{pmatrix} \begin{pmatrix} \mathbf{f}_C \\ \boldsymbol{\tau}_C \end{pmatrix} \geq \begin{pmatrix} 0 \\ \vdots \\ 0 \end{pmatrix}. \quad (14)$$

To the contrary, it is well known that any element of the solution of the inequalities should be an element of  $S_2(\mathbf{f}_C, \boldsymbol{\tau}_C)$ . Therefore, Eq.(14) is the necessary and sufficient condition to be an element of  $S_2(\mathbf{f}_C, \boldsymbol{\tau}_C)$ , and  $(-\mathbf{f}_G, -\boldsymbol{\tau}_G)$  is an internal element of  $S_2(\mathbf{f}_C, \boldsymbol{\tau}_C)$  from the assumption, we obtain

$$\begin{pmatrix} \mathbf{e}_1^T \\ \vdots \\ \mathbf{e}_Q^T \end{pmatrix} \begin{pmatrix} \mathbf{f}_G \\ \boldsymbol{\tau}_G \end{pmatrix} < \begin{pmatrix} 0 \\ \vdots \\ 0 \end{pmatrix}. \quad (15)$$

This implies that

$$\left( \left( \sum_{m=1}^M \mathbf{e}_m \delta_m \right)^T \right) \begin{pmatrix} \mathbf{f}_G \\ \boldsymbol{\tau}_G \end{pmatrix} < 0, \quad (16)$$

unless  $\forall m; \delta_m = 0$ , which shows that

$$\begin{aligned} \forall (\delta \mathbf{x}_G, \boldsymbol{\Omega}_G) \in S_1, (\delta \mathbf{x}_G, \boldsymbol{\Omega}_G) \neq 0; \\ ((\mathbf{x}_G)^T \quad (\boldsymbol{\Omega}_G)^T) \begin{pmatrix} \mathbf{f}_G \\ \boldsymbol{\tau}_G \end{pmatrix} < 0. \end{aligned} \quad (17)$$

That is, it is proved that the contact is always stable, since the work done by  $(-\mathbf{f}_G, -\boldsymbol{\tau}_G)$  is always negative for an arbitrary infinitesimal translation and rotation of the COG of the robot. (q.e.d.)

We propose  $(-\mathbf{f}_G, -\boldsymbol{\tau}_G)$  to be a stability criterion for the foot contact of a legged robot. The contact is strongly stable if the criterion is inside the polyhedral convex cone of the contact wrench. We will prove that the criterion is equivalent

to the ZMP when the robot walks on a horizontal plane as follows.

**Example 1: (Biped robot walking on a horizontal plane with sufficient friction)** Let us consider the case in which a biped robot walks on a horizontal plane as shown in Fig.2. Then the horizontal elements of  $\mathbf{f}_G$  and  $\boldsymbol{\tau}_G$  about  $z$ -axis

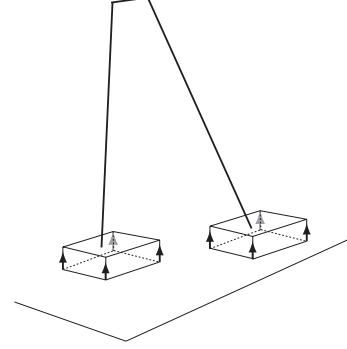

Fig. 2. Two feet on a horizontal plane

should always balance with the contact force and torque as

$$M \ddot{x}_G = \sum_{k=1}^K (\epsilon_k^1 - \epsilon_k^2), \quad (18)$$

$$M \ddot{y}_G = \sum_{k=1}^K (\epsilon_k^3 - \epsilon_k^4), \quad (19)$$

$$M x_G \ddot{y}_G - M y_G \ddot{x}_G + \dot{\mathcal{L}}_z = \sum_{k=1}^K \{ (\epsilon_k^3 - \epsilon_k^4) x_k - (\epsilon_k^1 - \epsilon_k^2) y_k \}. \quad (20)$$

The polyhedral convex cone of the contact wrench is the direct product of the linear subspace given by the right-hand side of Eqs.(18),(19) and (20) and a polyhedral convex cone in the complement of the subspace, and therefore the strong stability can be determined by checking if  $(\mathbf{f}_G, \boldsymbol{\tau}_G)$  is inside the polyhedral convex cone in the complement subspace. The relationship in the complement subspace can be written by

$$M(\ddot{z}_G + g) = \sum_{k=1}^K \epsilon_k^0, \quad (21)$$

$$M(\ddot{z}_G + g) y_G - M \ddot{y}_G z_G + \dot{\mathcal{L}}_x = \sum_{k=1}^K \epsilon_k^0 y_k - z_0 \sum_{k=1}^K (\epsilon_k^3 - \epsilon_k^4), \quad (22)$$

$$-M(\ddot{z}_G + g) x_G + M \ddot{x}_G z_G + \dot{\mathcal{L}}_y = -\sum_{k=1}^K \epsilon_k^0 x_k - z_0 \sum_{k=1}^K (\epsilon_k^1 - \epsilon_k^2), \quad (23)$$

where  $z_0$  is the height of the horizontal floor. Note that the second term of the right-hand sides in Eqs.(22) and (23) are independent to the positions of the contact points, since  $z$ -coordinate of all the contact points is  $z_0$ . Then we can set

$z_0 = 0$  without loss of the generality, and we obtain

$$M(\ddot{z}_G + g)y_G - M\ddot{y}_G z_G + \dot{\mathcal{L}}_x = \sum_{k=1}^K \epsilon_k^0 y_k, \quad (24)$$

$$-M(\ddot{z}_G + g)x_G + M\ddot{x}_G z_G + \dot{\mathcal{L}}_y = -\sum_{k=1}^K \epsilon_k^0 x_k. \quad (25)$$

From Eqs.(21),(24) and (25),  $(-\mathbf{f}_G, -\boldsymbol{\tau}_G)$  is an internal element of the polyhedral convex cone of the contact wrench given by Eqs.(6) and (7) if Eqs.(24) and (25) hold for at least three of positive  $\epsilon_k^0$ , and then the contact is strongly stable from Theorem 1.

Fig.3 illustrates the support polygon of the robot and the corresponding intersection of the polyhedral convex cone given by the right-hand sides of Eqs.(21),(24) and (25) with plane  $\mathbf{f}_z = M(\ddot{z}_G + g)$ . The set of  $((\boldsymbol{\tau}_C)_x, (\boldsymbol{\tau}_C)_y)$  is the dual polygon of the support polygon, since  $x_k$  and  $y_k$  are exchanged in the right-hand sides of Eqs.(24) and (25) with the minus sign in Eq.(25).

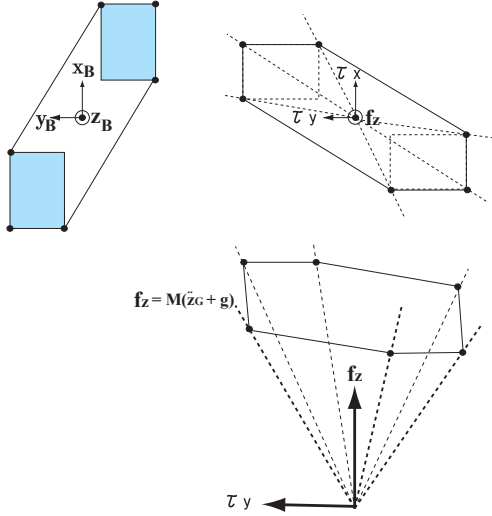

Fig. 3. Support polygon and an intersection of the polyhedral convex cone

Let us consider the same contact stability using the ZMP. The ZMP =  $(x_0, y_0)$  can be given by

$$\begin{aligned} x_0 &= \frac{Mx_G(\ddot{z}_G + g) - M(z_G - z_0)\ddot{x}_G - \dot{\mathcal{L}}_y}{M(\ddot{z}_G + g)}, \\ y_0 &= \frac{My_G(\ddot{z}_G + g) - M(z_G - z_0)\ddot{y}_G + \dot{\mathcal{L}}_x}{M(\ddot{z}_G + g)}. \end{aligned} \quad (26)$$

The ZMP is an internal point of the support polygon of the feet if

$$\begin{aligned} x_0 &= \sum_{k=1}^K \lambda_k x_k, \\ y_0 &= \sum_{k=1}^K \lambda_k y_k, \end{aligned} \quad (27)$$

$$\sum_{k=1}^K \lambda_k = 1, \quad \lambda_k \geq 0, \quad (28)$$

and at least three of  $\lambda_k$  are positive. Let  $z_0 = 0$ , and from Eqs.(26),(27) we obtain

$$\begin{aligned} \frac{M(\ddot{z}_G + g)x_G - Mz_G\ddot{x}_G - \dot{\mathcal{L}}_y}{M(\ddot{z}_G + g)} &= \sum_{k=1}^K \lambda_k x_k, \\ \frac{M(\ddot{z}_G + g)y_G - Mz_G\ddot{y}_G + \dot{\mathcal{L}}_x}{M(\ddot{z}_G + g)} &= \sum_{k=1}^K \lambda_k y_k. \end{aligned} \quad (29)$$

Now we can prove that the proposed criterion is equivalent to the ZMP in the case of Example 1. Let  $\epsilon = \sum_{k=1}^K \epsilon_k^0$ . Substituting Eq.(21) into Eqs.(24),(25), we get

$$\begin{aligned} \frac{M(\ddot{z}_G + g)x_G - Mz_G\ddot{x}_G - \dot{\mathcal{L}}_y}{M(\ddot{z}_G + g)} &= \sum_{k=1}^K \frac{\epsilon_k^0}{\epsilon} x_k, \\ \frac{M(\ddot{z}_G + g)y_G - Mz_G\ddot{y}_G + \dot{\mathcal{L}}_x}{M(\ddot{z}_G + g)} &= \sum_{k=1}^K \frac{\epsilon_k^0}{\epsilon} y_k. \end{aligned} \quad (30)$$

It is trivial that Eq.(30) should be identical with Eq.(29) since  $\sum_{k=1}^K \frac{\epsilon_k^0}{\epsilon} = 1$ . This proved that the proposed criterion is equivalent to the ZMP when a legged robot walks on a horizontal plane with sufficient friction.

The proposed criterion is more universal than the ZMP as described below. A question is if the criterion has any merit or demerit compared to the ZMP in the specific case of example 1. The proposed criterion does not need the division to find the ZMP in Eq.(26) and therefore its computation is more numerically stable especially when the vertical contact force is small. The trajectory of the ZMP can be plotted more comprehensively since it is a point on a plane. The proposed criterion should require an intersection plane of  $\mathbf{f}_z$  to be plotted on a plane. See Fig.3.

**Example 2: (Biped robot walking on stairs with sufficient friction)** Let us consider the case in which a biped robot walks on stairs as shown in Fig.4. The contact stability can not be determined based on the ZMP without some approximation. Let one foot contact with a stair at  $\mathbf{p}_k, k = 1, \dots, K_{F1}$  whose height is  $z_{F1}$  and another at  $\mathbf{p}_k, k = K_{F1}+1, \dots, K_{F1}+K_{F2}$  whose height is  $z_{F2}$ . Then Eqs.(18),(19), (21) and (20) remain identical essentially, and Eqs.(22) and (23) become

$$\begin{aligned} &M(\ddot{z}_G + g)y_G - M\ddot{y}_G z_G + \dot{\mathcal{L}}_x \\ &= \sum_{k=1}^{K_{F1}+K_{F2}} \epsilon_k^0 y_k \\ &- \left( \sum_{k=1}^{K_{F1}} \epsilon_k^3 - \sum_{k=1}^{K_{F1}} \epsilon_k^4 \right) z_{F1} - \left( \sum_{k=K_{F1}+1}^{K_{F1}+K_{F2}} \epsilon_k^3 - \sum_{k=K_{F1}+1}^{K_{F1}+K_{F2}} \epsilon_k^4 \right) z_{F2}, \end{aligned} \quad (31)$$

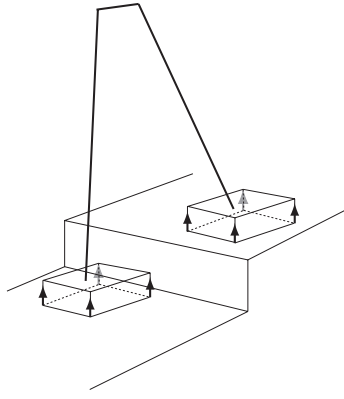

Fig. 4. Two feet on stairs

$$\begin{aligned}
& -M(\ddot{z}_G + g)x_G + M\ddot{x}_G z_G + \dot{\mathcal{L}}_y \\
& = - \sum_{k=1}^{K_{F1}+K_{F2}} \epsilon_k^0 x_k \\
& + \left( \sum_{k=1}^{K_{F1}} \epsilon_k^1 - \sum_{k=1}^{K_{F1}} \epsilon_k^2 \right) z_{F1} + \left( \sum_{k=K_{F1}+1}^{K_{F1}+K_{F2}} \epsilon_k^1 - \sum_{k=K_{F1}+1}^{K_{F1}+K_{F2}} \epsilon_k^2 \right) z_{F2}.
\end{aligned}$$

The second term in the right-hand side of Eq.(31) or Eq.(32) is the contact torque about  $x$ -axis of one foot and the third term that of another foot. Therefore the balance of the torque about  $x$  or  $y$ -axis should depend on the ratio of the horizontal force applied to two feet. Theorem 1 is still valid in the case, but the strong stability should be checked in the six-dimensional force and torque space rather than the three dimensional space in the case of example 1. Note that the decision of the strong stability can be computed in a five dimensional space for example 2 and in a two dimensional space for example 1, since the algorithm should check if the direction of  $(-\mathbf{f}_G, -\boldsymbol{\tau}_G)$  is include in the polyhedral convex cone.

### C. Weak stability criterion

When the sufficient friction assumption is removed, it is not possible to determine the strong stability in general[7], [9]. In the proof of Theorem 1,

$$\left( (\mathbf{n}_k + \mu_k \mathbf{t}_k^l)^T \quad (\mathbf{p}_k \times (\mathbf{n}_k^T + \mu_k \mathbf{t}_k^l))^T \right) \begin{pmatrix} \Delta x_G \\ \Omega_G \end{pmatrix} \geq 0, \quad (33)$$

does not hold instead of Eq.(8) when a slip occurs at  $\mathbf{p}_k$ .

Then we may consider to check the weak stability, but the weak stability always holds for the contact of a legged robot when the motion of the robot is feasible. Let us consider the causality of our problem. The inputs of the equations of motions of the robot are the joint torque of the robot and the gravity. Then the contact force between the robot and the environment is determined physically, and the acceleration of the robot is generated which determines the inertia force and torque applied to the robot.  $(\mathbf{f}_G, \boldsymbol{\tau}_G)$  are the sum of the inertia force and torque and those from the gravity and therefore must balance with the contact force and torque.

When motion patterns of a legged robot is planned, the planner may generate motion patterns which are not feasible in the physical world. So the weak stability criterion can be used to check if the planned motions should be feasible, but it does not tell if the contact should be stable. An alternative idea is to judge if  $(-\mathbf{f}_G, -\boldsymbol{\tau}_G)$  should be included in a proper subset of the polyhedral convex cone of the contact wrench. Then the contact is likely to be stable with a margin, but there is no guarantee that the contact should be stable. The idea is summarized as follows

**Definition 2: (Weak stability criterion)** If  $(-\mathbf{f}_G, -\boldsymbol{\tau}_G)$  is an element of a proper subset of the polyhedral convex cone of the contact wrench given by Eqs.(4) and (5), the contact is called *sufficiently weakly stable* to  $(\mathbf{f}_G, \boldsymbol{\tau}_G)$ .

## IV. PATTERN GENERATOR OF A HUMANOID ROBOT

A pattern generator of a humanoid robot is presented as an application of the proposed stability criterion.

### A. Equations of momentum

See Fig.1 again. Let  $\mathbf{v}_B$  and  $\boldsymbol{\omega}_B$  be the velocity and angular velocity of  $\Sigma_B$  with respect to  $\Sigma_R$  respectively and  $\dot{\boldsymbol{\theta}}$  ( $n \times 1$ ) joint vector of the robot. Then the momentum  $\mathcal{P}$  of the robot (32) and angular momentum  $\mathcal{L}$  about the COG can be given by

$$\begin{bmatrix} \mathcal{P} \\ \mathcal{L} \end{bmatrix} = \begin{bmatrix} M\mathbf{E} & -M\hat{\mathbf{r}}_{B \rightarrow G} & M\dot{\boldsymbol{\theta}} \\ \mathbf{0} & \tilde{\mathbf{I}} & \mathbf{H}_{\dot{\boldsymbol{\theta}}} \end{bmatrix} \begin{bmatrix} \mathbf{v}_B \\ \boldsymbol{\omega}_B \\ \dot{\boldsymbol{\theta}} \end{bmatrix}, \quad (34)$$

where  $\mathbf{E}$  is the  $(3 \times 3)$  unit matrix,  $\mathbf{r}_{B \rightarrow G}$  the position vector from  $\mathbf{p}_B$  to the COG,  $\tilde{\mathbf{I}}$  the  $(3 \times 3)$  inertia matrix about the COG,  $M\dot{\boldsymbol{\theta}}$  and  $\mathbf{H}_{\dot{\boldsymbol{\theta}}}$  the  $(3 \times 3)$  inertia matrix that gives the momentum and angular momentum depending on the joint velocities, and operation  $\hat{\cdot}$  converts a  $(3 \times 1)$  vector into the equivalent  $(3 \times 3)$  skew symmetric matrix. Let  $\mathbf{v}_{F_i}$  and  $\boldsymbol{\omega}_{F_i}$  be the velocity and angular velocity of  $\Sigma_{F_i}$  ( $i = 1, 2$ ) respectively, where  $\Sigma_{F_i}$  ( $i = 1, 2$ ) are coordinates fixed to the tip of the feet respectively. Then we have

$$\begin{bmatrix} \mathbf{v}_{F_i} \\ \boldsymbol{\omega}_{F_i} \end{bmatrix} = \begin{bmatrix} \mathbf{E} & -\hat{\mathbf{r}}_{B \rightarrow F_i} \\ \mathbf{0} & \mathbf{E} \end{bmatrix} \begin{bmatrix} \mathbf{v}_B \\ \boldsymbol{\omega}_B \end{bmatrix} + \mathbf{J}_{leg_i} \dot{\boldsymbol{\theta}}_{leg_i}, \quad (35)$$

where  $\mathbf{J}_{leg_i}$  is the  $(6 \times 6)$  Jacobian matrix determined by the structure of the leg and its posture,  $\mathbf{r}_{B \rightarrow F_i}$  the position vector from  $\mathbf{p}_{L_i}$  to the tip of the leg,  $\dot{\boldsymbol{\theta}}_{leg_i}$  ( $i = 1, 2$ ) the  $(6 \times 1)$  joint velocity vector of the leg. From Eq.(35),  $\dot{\boldsymbol{\theta}}_{leg_i}$  can be given by

$$\dot{\boldsymbol{\theta}}_{leg_i} = \mathbf{J}_{leg_i}^{-1} \begin{bmatrix} \mathbf{v}_{F_i} \\ \boldsymbol{\omega}_{F_i} \end{bmatrix} - \mathbf{J}_{leg_i}^{-1} \begin{bmatrix} \mathbf{E} & -\hat{\mathbf{r}}_{B \rightarrow F_i} \\ \mathbf{0} & \mathbf{E} \end{bmatrix} \begin{bmatrix} \mathbf{v}_B \\ \boldsymbol{\omega}_B \end{bmatrix}, \quad (36)$$

when  $\mathbf{J}_{leg_i}$  is regular. Let us impose an artificial constraint to the tip of the hands to move the tip by a desired velocity, then  $\dot{\boldsymbol{\theta}}_{arm_i}$  can be given by

$$\dot{\boldsymbol{\theta}}_{arm_i} = \mathbf{J}_{arm_i}^{-1} \begin{bmatrix} \mathbf{v}_{H_i} \\ \boldsymbol{\omega}_{H_i} \end{bmatrix} - \mathbf{J}_{arm_i}^{-1} \begin{bmatrix} \mathbf{E} & -\hat{\mathbf{r}}_{B \rightarrow H_i} \\ \mathbf{0} & \mathbf{E} \end{bmatrix} \begin{bmatrix} \mathbf{v}_B \\ \boldsymbol{\omega}_B \end{bmatrix}, \quad (37)$$

where the symbols are defined in the same way as the leg and  $\mathbf{J}_{arm_i}$  is assumed to be regular.

Let us decompose the joint velocity vector into the leg part  $\dot{\theta}_{leg_1}, \dot{\theta}_{leg_2}$  and the arm part  $\dot{\theta}_{arm_1}, \dot{\theta}_{arm_2}$  to compute the momentum under the constraints, and the inertia matrices correspondingly as

$$\begin{aligned}\dot{\theta} &= [\dot{\theta}_{leg_1}^T \quad \dot{\theta}_{leg_2}^T \quad \dot{\theta}_{arm_1}^T \quad \dot{\theta}_{arm_2}^T]^T, \\ M_{\dot{\theta}} &= [M_{leg_1} \quad M_{leg_2} \quad M_{arm_1} \quad M_{arm_2}], \\ H_{\dot{\theta}} &= [H_{leg_1} \quad H_{leg_2} \quad H_{arm_1} \quad H_{arm_2}].\end{aligned}$$

Substituting Eqs.(36) and (37) into into Eq.(34), we can derive the relationship between the momentum and angular momentum of the robot and the velocity of the robot under the constraint as

$$\begin{bmatrix} \mathcal{P} \\ \mathcal{L} \end{bmatrix} = \begin{bmatrix} M_B^* \\ H_B^* \end{bmatrix} \xi_B + \sum_{i=1}^2 \left\{ \begin{bmatrix} M_{F_i}^* \\ H_{F_i}^* \end{bmatrix} \xi_{F_i} + \begin{bmatrix} M_{H_i}^* \\ H_{H_i}^* \end{bmatrix} \xi_{H_i} \right\}, \quad (38)$$

where

$$\xi_B \equiv \begin{bmatrix} v_B \\ \omega_B \end{bmatrix}, \quad \xi_{F_i} \equiv \begin{bmatrix} v_{F_i} \\ \omega_{F_i} \end{bmatrix}, \quad \xi_{H_i} \equiv \begin{bmatrix} v_{H_i} \\ \omega_{H_i} \end{bmatrix},$$

$$\begin{aligned} \begin{bmatrix} M_B^* \\ H_B^* \end{bmatrix} &\equiv \begin{bmatrix} ME & -M\hat{r}_{B \rightarrow G} \\ \mathbf{0} & \hat{I} \end{bmatrix} \\ &\quad - \sum_{i=1}^2 \begin{bmatrix} M_{F_i}^* \\ H_{F_i}^* \end{bmatrix} \begin{bmatrix} E & -\hat{r}_{B \rightarrow F_i} \\ \mathbf{0} & E \end{bmatrix} \\ &\quad - \sum_{i=1}^2 \begin{bmatrix} M_{H_i}^* \\ H_{H_i}^* \end{bmatrix} \begin{bmatrix} E & -\hat{r}_{B \rightarrow H_i} \\ \mathbf{0} & E \end{bmatrix}, \\ \begin{bmatrix} M_{F_i}^* \\ H_{F_i}^* \end{bmatrix} &\equiv \begin{bmatrix} M_{leg_i} \\ H_{leg_i} \end{bmatrix} J_{leg_i}^{-1}, \\ \begin{bmatrix} M_{H_i}^* \\ H_{H_i}^* \end{bmatrix} &\equiv \begin{bmatrix} M_{arm_i} \\ H_{arm_i} \end{bmatrix} J_{arm_i}^{-1}. \end{aligned}$$

### B. Generation of the reference momentum pattern by a preview control

When the ZMP is used as the stability criterion of the foot contact of a legged robot, a reference trajectory of the ZMP is first planned and that of the COG is generated by solving the ZMP equations. The reference trajectory of the ZMP is usually chosen to be a smooth curve inside the support polygon of the robot. When the proposed stability criterion is used, a reference trajectory of the sum of the gravity and the inertia wrench is first planned to balance a smooth one-dimensional manifold inside the polyhedral convex cone of the contact wrench, and that of the COG is generated by solving the differential equations which relate the derivatives of the COG position and the reference wrench.

For example, we can simply take the average of possible wrench vectors as

$$f^{ref} = \sum_{k=1}^K \sum_{l=1}^L \bar{\epsilon} (n_k + \mu_k t_k^l), \quad (39)$$

$$\tau^{ref} = \sum_{k=1}^K \sum_{l=1}^L \bar{\epsilon} p_k \times (n_k + \mu_k t_k^l), \quad (40)$$

$$\bar{\epsilon} = \frac{M(\ddot{z}_G + g)}{KL} > 0, \quad (41)$$

then  $(f^{ref}, \tau^{ref})$  should be inside the contact wrench and a smooth one-dimensional manifold can be generated by connecting such wrenches smoothly.

Let  $f^{ref} = (f_x^{ref}, f_y^{ref}, f_z^{ref})$  and  $\tau^{ref} = (\tau_x^{ref}, \tau_y^{ref}, \tau_z^{ref})$ . Then the balance of the moment about  $x$ -axis and  $y$ -axis can be written respectively by

$$M(\ddot{z}_G + g)y_G - M\ddot{y}_G z_G + \dot{L}_x = \tau_x^{ref}, \quad (42)$$

$$-M(\ddot{z}_G + g)x_G + M\ddot{x}_G z_G + \dot{L}_y = \tau_y^{ref}, \quad (43)$$

where  $\tau_x^{ref}$  and  $\tau_y^{ref}$  can be found by taking a positive sum of the edges of the polyhedral convex cone of the contact wrench like Eq.(41).

When the reference of  $\xi_B, \xi_{F_i}$  and  $\xi_{H_i}$  are given, the reference angular momentum  $\mathcal{L}^{ref}$  can be computed by Eq.(38) without considering the contact stability and then Eqs.(42) and (43) can be written as

$$M(\ddot{z}_G + g)y_G - M\ddot{y}_G z_G = \tau_x^{ref} - \dot{L}_x^{ref}, \quad (44)$$

$$-M(\ddot{z}_G + g)x_G + M\ddot{x}_G z_G = \tau_y^{ref} - \dot{L}_y^{ref}. \quad (45)$$

In the following, let us consider the motions for which we can assume that  $z_G$  is approximately constant and  $\ddot{z}_G$  is negligible. We also assume that we have a sufficient friction. Then Eqs.(42) and (43) become respectively

$$Mgy_G - M\ddot{y}_G z_G = \tau_x^{ref} - \dot{L}_x^{ref}, \quad (46)$$

$$-Mgx_G + M\ddot{x}_G z_G = \tau_y^{ref} - \dot{L}_y^{ref}, \quad (47)$$

which can be re-written by state equations as

$$\begin{aligned} \frac{d}{dt} \begin{pmatrix} y_G \\ \dot{y}_G \\ \ddot{y}_G \end{pmatrix} &= \begin{pmatrix} 0 & 1 & 0 \\ 0 & 0 & 1 \\ 0 & 0 & 0 \end{pmatrix} \begin{pmatrix} y_G \\ \dot{y}_G \\ \ddot{y}_G \end{pmatrix} + \begin{pmatrix} 0 \\ 0 \\ 1 \end{pmatrix} u_y, \\ \xi_{tx} &= (Mg \quad 0 \quad -Mz_G) \begin{pmatrix} y_G \\ \dot{y}_G \\ \ddot{y}_G \end{pmatrix}, \\ \frac{d}{dt} \begin{pmatrix} x_G \\ \dot{x}_G \\ \ddot{x}_G \end{pmatrix} &= \begin{pmatrix} 0 & 1 & 0 \\ 0 & 0 & 1 \\ 0 & 0 & 0 \end{pmatrix} \begin{pmatrix} x_G \\ \dot{x}_G \\ \ddot{x}_G \end{pmatrix} + \begin{pmatrix} 0 \\ 0 \\ 1 \end{pmatrix} u_x, \\ \xi_{ty} &= (-Mg \quad 0 \quad Mz_G) \begin{pmatrix} x_G \\ \dot{x}_G \\ \ddot{x}_G \end{pmatrix}, \end{aligned} \quad (48)$$

where

$$\xi_{tx}^{ref} = \tau_x^{ref} - \dot{L}_x^{ref}, \quad (49)$$

$$\xi_{ty}^{ref} = \tau_y^{ref} - \dot{L}_y^{ref}, \quad (50)$$

$$u_x = \ddot{x}_G, \quad (51)$$

$$u_y = \ddot{y}_G. \quad (52)$$

A solution of the state equations can be found by a preview control[5]. Let the solution be  $(x_G^{ref}, y_G^{ref})$  and  $\ddot{z}_G$  determined by Eq.(38) be  $\ddot{z}_G^{ref}$ . Then the wrench

$(x_G^{ref}, y_G^{ref}, z_G^{ref}, \tau_x^{ref}, \tau_y^{ref}, \tau_z^{ref})$  should be inside the contact wrench from the sufficient friction assumption, and the reference of the momentum  $(\mathcal{P}_x^{ref}, \mathcal{P}_y^{ref})$  can be given by

$$\mathcal{P}_x^{ref} = M\dot{x}_G^{ref}, \quad (53)$$

$$\mathcal{P}_y^{ref} = M\dot{y}_G^{ref}, \quad (54)$$

$$\mathcal{P}_z^{ref} = M\dot{z}_G^{ref}. \quad (55)$$

### C. Resolved momentum control

The resolved momentum control proposed by Kajita et al.[4] is applied here. The equations of momentum Eq.(38) can be rewritten as

$$\mathbf{y} = \mathbf{A}\boldsymbol{\xi}_B, \quad (56)$$

where

$$\mathbf{y} \equiv \begin{bmatrix} \mathcal{P}^{ref} \\ \mathcal{L}^{ref} \end{bmatrix} - \sum_{i=1}^2 \begin{bmatrix} \mathbf{M}_{F_i}^* \\ \mathbf{H}_{F_i}^* \end{bmatrix} \boldsymbol{\xi}_{F_i}^{ref} - \sum_{i=1}^2 \begin{bmatrix} \mathbf{M}_{H_i}^* \\ \mathbf{H}_{H_i}^* \end{bmatrix} \boldsymbol{\xi}_{H_i}^{ref} \quad (57)$$

$$\mathbf{A} \equiv \begin{bmatrix} \mathbf{M}_B^* \\ \mathbf{H}_B^* \end{bmatrix}. \quad (58)$$

From Eq.(56),  $\boldsymbol{\xi}_B$  that realizes a reference momentum  $\mathcal{P}^{ref}$ , angular momentum  $\mathcal{L}^{ref}$ , velocity of foot  $\boldsymbol{\xi}_{F_i}^{ref}$  and velocity of hand  $\boldsymbol{\xi}_{H_i}^{ref}$  can be given by

$$\boldsymbol{\xi}_B = \mathbf{A}^\dagger \mathbf{y}. \quad (59)$$

From obtained  $\boldsymbol{\xi}_B$ , the joint velocity of the legs and arms can be given by

$$\dot{\boldsymbol{\theta}}_{leg_i} = \mathbf{J}_{leg_i}^{-1} \left( \boldsymbol{\xi}_{F_i}^{ref} - \begin{bmatrix} \mathbf{E} & -\hat{\mathbf{r}}_{B \rightarrow F_i} \\ \mathbf{0} & \mathbf{E} \end{bmatrix} \boldsymbol{\xi}_B \right), \quad (60)$$

$$\dot{\boldsymbol{\theta}}_{arm_i} = \mathbf{J}_{arm_i}^{-1} \left( \boldsymbol{\xi}_{H_i}^{ref} - \begin{bmatrix} \mathbf{E} & -\hat{\mathbf{r}}_{B \rightarrow H_i} \\ \mathbf{0} & \mathbf{E} \end{bmatrix} \boldsymbol{\xi}_B \right). \quad (61)$$

### D. Simulation example

The proposed pattern generator is implemented on dynamic simulator OpenHRP[6]. Fig.5 shows that humanoid robot HRP-2 walks on a horizontal plane with a sufficient friction. Fig.6 shows an example of the reference trajectory of



Fig. 5. HRP-2 walks on a horizontal plane with a sufficient friction

$(\tau_x^{ref}, \tau_y^{ref})$  with the polyhedral convex cone of the contact wrench on the intersection plane  $f_z = Mg$  in  $f_z \tau_x \tau_y$  space, where each polygon corresponds to the contact cone at each step. The reference trajectory is the dual of the ZMP trajectory

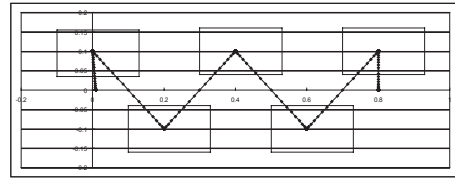

Fig. 6. Example of the reference contact moment

as illustrated in Fig.3.

## V. CONCLUSIONS

This paper proposed a universal stability criterion of the foot contact of legged robots. The proposed method checks if the sum of the gravity and the inertia wrench applied to the COG of the robot, which was proposed to be the stability criterion, is inside the polyhedral convex cone of the contact wrench between the feet of a robot and its environment. The contribution of the paper is summarized as follows.

- The proposed criterion can be used to determine the strong stability of the foot contact even when a robot walks on an arbitrary terrain other than a horizontal plane and/or when the hands of the robot are in contact with the terrain under the assumption that sufficient friction should exist at the contact.
- It was proved that the determination is equivalent to check if the ZMP is inside the support polygon of the feet when the robot walks on a horizontal plane with sufficient friction.
- The criterion can also be used to determine if the foot contact is sufficiently weakly stable when the friction follows a physical law.

The ZMP can be a rigorous stability criterion of the foot contact of legged robots in a specific case in which the robots walk on a flat plane with a sufficient friction. The proposed criterion is an equivalent criterion in the specific case, and it is also a rigorous criterion in more universal cases. We are afraid that the only advantage of the ZMP over the proposed criterion is that the ZMP can be drawn on a plane as shown in Fig.3. Therefore, we claim to say ‘‘Adios ZMP’’.

The part of the pattern generator after Eq.(46) assumes that  $z_G$  is approximately constant and  $\dot{z}_G$  is negligible. The future works include the removal of the assumptions, then a variety of motions can be planned using the proposed criterion which should prove the merits of the proposed criterion over the ZMP. When the goal is attained, we can say ‘‘Adios ZMP’’ in a loud voice.

## REFERENCES

- [1] D.J.Balkcom and J.C.Trinkle, Computing wrench cones for planar rigid body contact tasks, Int. J. Robotics Research, vol.21, no.12, pp.1053-1066, 2002.

- [2] A.Goswami, Postural stability of biped robots and the foot rotation indicator (FRI) point, *Int. J. Robotics Research*, vol.19, no.6, pp.523-533, 1999.
- [3] K.Harada, S.Kajita, K.Kaneko, and H.Hirukawa, ZMP Analysis for Arm/Leg Coordination, *Proc. IEEE/RSJ Int. Conf. on Intelligent Robots and Systems*, Oct.2003.
- [4] S.Kajita, F.Kanehiro, K.Kaneko, K.Fujiwara, K.Harada, K.Yokoi, and H.Hirukawa, Resolved Momentum Control:Humanoid Motion Planning based on the Linear and Angular Momentum, *Proc. IEEE/RSJ Int. Conf. on Intelligent Robots and Systems*, Oct. 2003.
- [5] S.Kajita, F. Kanehiro, K. Kaneko, K. Fujiwara, K. Harada, K. Yokoi, H. Hirukawa, Biped Walking Pattern Generation by using Preview Control of Zero-Moment Point, *Proc. IEEE Int. Conf. on Robotics and Automation*, 2003.
- [6] F.Kanehiro, H.Hirukawa and S.Kajita, OpenHRP: Open Architecture Humanoid Robotics Platform, *International Journal of Robotics Research*, vol.23, no.2, pp.155-165, 2004.
- [7] J.Pang and J.Trinkle, Stability characterizations of rigid body contact problems with Coulomb friction, *Zeitschrift fur Angewandte Mathematik und Mechanik*, vol.80, no.10, pp.643-663, 2000.
- [8] T.Saida, Y.Yokokoji and T.Yoshikawa, FSW (feasible solution of wrench) for Multi-legged Robots, *Proc. IEEE Int. Conf. on Robotics and Automation*, pp.3815-3820, 2003.
- [9] J.Trinkle, J.Pang, S.Sudarsky and G.Lo, On dynamic multi-rigid-body contact problems with Coulomb friction, *Zeitschrift fur Angewandte Mathematik und Mechanik*, vol.77, no.4, pp.267-279, 1997.
- [10] M.Vukobratovic and J.Stepanenko, On the stability of Anthropomorphic Systems, *Mathematical Biosciences*, vol.15, pp.1-37, 1972.
- [11] K.Yoneda and S.Hirose, Tumble Stability Criterion of Integrated Locomotion and Manipulation, *Proc. IEEE/RSJ Int. Conf. on Intelligent Robots and Systems*, pp.870-876, 1996.